

RYOBI®

RYOBI 3302H
2-COLOR OFFSET PRESS

**OPERATION
MANUAL**



WARNING

This operation manual is written to assure that this machine is used safely and effectively. Read this manual and understand its contents fully before doing the machine operation and maintenance. The operator and supervisor must not allow a person who does not understand this machine to operate it.

This manual also includes the explanation of the optional accessories so as to explain the total capabilities of the machine.

Copyright © 1998 Ryobi Limited. All rights reserved. This manual may not be duplicated, reproduced or transmitted (in whole or in part) in any form or by any means, electronic or mechanical, (including without limitation photocopy, facsimile, recording or any information storage and retrieval system) without the prior written consent of Ryobi Limited.

Disclaimer of Warranties (Express or Implied). While due care has been taken in the preparation of this manual, Ryobi Limited makes no representation or warranties with respect to the adequacy or accuracy hereof and specifically disclaims any implied warranties of merchantability or fitness for any particular purpose. Further, Ryobi Limited reserves the right to revise this publication and to make changes (both substantial and insubstantial in nature) in the contents hereof from time to time hereafter without obligation of Ryobi Limited to notify any person or organization of such revisions or changes.

Safety Warning. Safety devices have been installed for your protection and safety. The removal, disconnection or alteration of any safety guard, protective cover, safety interlock or other safety or protective device comprising part of the equipment described herein poses an undue safety hazard.

Disclaimer of Liability. Ryobi Limited disclaims any responsibility or liability for personal injury, death or property damage caused by or arising out of (1) the removal, disconnection or alteration of any safety guard, protective cover, safety interlock or other safety or protective device comprising part of the equipment described herein, (2) the use of any parts other than the parts supplied by Ryobi Limited, or (3) the failure of the person or persons operating the equipment described herein or servicing or repairing the same to observe all operating and safety procedures and warnings contained herein.

FCC Warning (*FCC Rules apply to U.S.A. only.*)

This equipment has been tested and found to comply with the limits for a Class A digital device, pursuant to part 15 of the FCC Rules. These limits are designed to provide reasonable protection against harmful interference when the equipment is operated in a commercial environment. This equipment generates, uses and can radiate radio frequency energy and, if not installed and used in accordance with the instruction manual, may cause harmful interference to radio communications. Operation of this equipment in a residential area is likely to cause harmful interference in which case the user will be required to correct the interference at his own expense.

Warning

1. This manual may not be copied partially or fully without the permission of Ryobi Limited.
2. The contents of this manual are subject to change without any notification.
3. This manual's contents have been carefully checked but if you notice something that is unclear, a mistake, or something is left out, please contact Ryobi Limited.
4. We are not responsible for any machine poor operation results.

✓ check WMD to water filter roller

Put pencil (service #9) into up chrome roller
Then check Prod. make ~~sure~~ sure to return
to "0"

- make water roller speed is set to "0"



WARNING

Concerning the machine operation

- When operating the machine carelessly, a serious injury or serious accident may occur.
- The operator and person doing the maintenance should read this manual carefully before operating or doing the maintenance on this machine.
- Never operate or do the maintenance on this machine until you understand this manual completely.
- Never replace any parts other than the consumables shown in this manual by yourself. Please call the dealer who you purchased the machine from.
- Never install, move, or scrap this machine by yourself. Please call the dealer who you purchased the machine from.
- Use the after sales parts and consumables which are supplied from the manufacturer, or recommended by the manufacturer. These parts and consumables are listed in the parts list which is supplied with the machine.

Concerning the handling of this manual

- Keep this manual in a place where the operator and person doing the maintenance can refer to it at any time when required.
- If this manual is lost or damaged, please order a new one from the dealer who you purchased the machine from.

When transferring this machine

- Please prepare this machine to be the same condition as when you purchased it.
- Please attach this manual with the machine.



2-COLOR OFFSET PRESS
RYOBI 3302H

OPERATION MANUAL

Safety
Operation
Edition

Introduction
Edition

Operation
Edition

Maintenance
Edition

Optional
Accessories
Edition

PREFACE

Thank you for purchasing our RYOBI product.

This operation manual is written to assure that this machine is used safely and effectively. Read this manual fully before operating this machine. Completely understand the content of the safety operation, name and function, operation, and maintenance and inspection sections before operating the machine. Failure to follow the operation instructions in this manual may result in a serious accident. There are certain illustrations in this manual in which the cover or safety cover has been omitted to allow better understanding. However when operating the machine, mount all the covers and safety covers properly.

The purpose of this operation manual is to provide necessary safety hints about the correct range of applications for which the machine is intended. This operation manual is designed according to the European standard EN 292, part 1.

The following marks indicate items that careful attention should be paid in this manual to assure the safe operation. So please operate the machine only after understanding this manual completely.

Meaning of the marks



DANGER

This mark is used in the safety precautions and on the warning labels at places to indicate an imminent dangerous condition in which a death or serious injury may occur if the danger is not avoided.

In these safety precautions, the safety steps that have to be followed to avoid the danger are explained.



WARNING

This mark is used in the safety precautions and on the warning labels at places to indicate a potential dangerous condition in which a death or serious injury may occur if the danger is not avoided.

In these safety precautions, the safety steps that have to be followed to avoid the danger are explained.



CAUTION

This mark is used in the safety precautions and on the warning labels at places to indicate a potential dangerous condition in which an injury or preventable accident may occur if the danger is not avoided.

In these safety precautions, the safety steps that have to be followed to avoid the danger are explained.

CONTENTS

Safety Operation Edition

Chapter 1 Warning Labels

Warning labels	13
Place to apply the warning labels	15

Chapter 2 Precautions in the Operation Environment

Use and storage of organic solvent	17
Machine noise	17

Chapter 3 Precautions when Installing and Moving the Machine

Machine dimensions, weight, and power	18
Machine installing and moving	19

Chapter 4 Precautions when Operating

Preparation and procedures if an emergency happens!	20
Cautions for clothes!	20
Mount the covers and safety devices properly! Never alter the safety devices!	20
Never “crawl” and “work” at the same time!	21
Mount the cylinder gap safety covers properly!	21
Be sure of what the other people are doing!	21
Never touch the rotating parts!	21
Stop the machine before doing the setting around the rotating parts! (in the delivery section)	22
Never insert your hand inside when pulling out a sheet!	22
Never touch the electrical parts with wet hands!	23
Keep the area around the machine clean!	23
Never use broken tools!	23
Never put your hand on the feeder pile while it is rising!	23
Stop the machine before doing the setting around the rotating parts! (in the feeder section)	24
Stop the machine before doing the setting around the rotating parts! (on the feeder board)	24

Chapter 5 Precautions when Doing Maintenance

Turn off the power before doing the lubrication and maintenance!	25
Mount the covers and safety devices properly! Never alter the safety devices!	25
Stop the rotation before cleaning the cylinders and rollers!	25
Wear safety goggles before supplying or replacing the chemicals!	25
Wear safety goggles before using the air gun!	26
Adjustment and maintenance that should be done by the operator!	27
Turn off the power before cleaning the static eliminator!	27
Never replace any parts other than the consumables!	27

Chapter 6 Safety Device

Safety device operation indication	28
Safety device function explanation	30

Introduction Edition

Chapter 1 Machine Outline

1-1 Specifications	35
1-2 Mechanical Layout	37
1-3 Roller Arrangement	38
1-4 Cylinder Packing and Plate and Blanket Size	39

Chapter 2 Name and Function of Each Part

2-1 Feeder Section Operation Panel	40
2-2 Delivery Section Operation Panel	44
2-3 Ink and Water Operation Panel	49
2-4 Crawl Operation Panel	50
2-5 Unit Control Panel	51
2-6 Delivery Section Auxiliary Switch Panel	52
2-7 Paper Feed Section	53
2-8 Printing Section	57
2-9 Delivery Section	62

Operation Edition

Chapter 1 Operation Procedures

1. Plate Making	67
2. Water Section Preparation	68
3. Mounting the Plate (Metal Plate)	70
4. Setting the Paper Feed Section	72
5. Setting the Registration Section	78
6. Setting the Delivery Section	83
7. Test Feeding	85
8. Setting the Ink Section	86
9. Setting the Impression Pressure Adjustment Dial	88
10. Setting the Delivery Section Auxiliary Switch Panel	88
11. Test Printing	90
12. Adjustment of the Image Position	92
13. Printing	96

Chapter 2 Printing Practice

2-1 Minimum Size Paper Printing (Point)	99
2-2 Thin Paper Feeding [Paper with a thickness less than 0.08 mm (0.0031")] (Point)	102
2-3 Paper Feed and Delivery of Curled Paper (Point)	105
2-4 Polyester Plate Printing (Point)	106
2-5 Positioning the Image when Printing a Third Color and Fourth Color in 2 Passes (Point)	108

Maintenance Edition

Chapter 1 Maintenance after the Printing

1. Cleaning the Ink Section	111
2. Cleaning the Water Section	114
3. Cleaning the Cylinder Section	116
4. Plate Preservation	118

Chapter 2 Periodic Inspection

1. Checking the Roller Pressure	119
2. Checking the Plate Pressure and Impression Pressure	130
3. Checking the Air Pump Nozzle Section	132

Chapter 3 Periodic Maintenance

1. Maintenance Item List	133
2. Maintenance Points	134

Chapter 4 Replacing the Supplies

1. Replacing the Blanket	144
2. Replacing the Sheet Separator	146
3. Replacing the Water Form Roller and Metering Roller	147
4. Replacing the Water Control Wiper	148

Chapter 5 Troubles and Countermeasures

5-1 Error Message	149
5-2 Other Troubles	149

Optional Accessories Edition

Chapter 1 Dampening Solution Cooling/Circulation Device

1-1 Outline	157
1-2 Name and Function of Each Part	157
1-3 Operation Procedures	159
1-4 Maintenance	160

Chapter 2 PCS-F

2-1 Outline	162
2-2 Specifications	163
2-3 Name and Function of Each Part	165
2-4 Operation Procedures	
1. Setting the Ink Fountain Key (Manual Operation)	168
2. Formatting a Floppy Disk	169
3. Saving the Ink Fountain Key Opening Volume Data	170
4. Reading and Presetting the Ink Fountain Key Opening Data	171
5. Returning to the Ink Fountain Key 0 Point	172
6. Copying the Ink Fountain Key Opening Data	173
7. Deleting the Data from a Floppy Disk	174
8. Setting the Color and Conversion Curve Number for Each Unit	175
9. Setting the Ink Section	179
2-5 Maintenance after the Printing	
1. Cleaning the Ink Fountain and Ink Fountain Roller	181

Chapter 3 Blanket Cleaning Device

3-1 Outline	184
3-2 Name and Function of Each Part	184
3-3 Operation Procedures	186
3-4 Maintenance	188
3-5 Caution when Replacing the Blanket	190

ILLUSTRATED CONTENTS

OPS

Operation Side

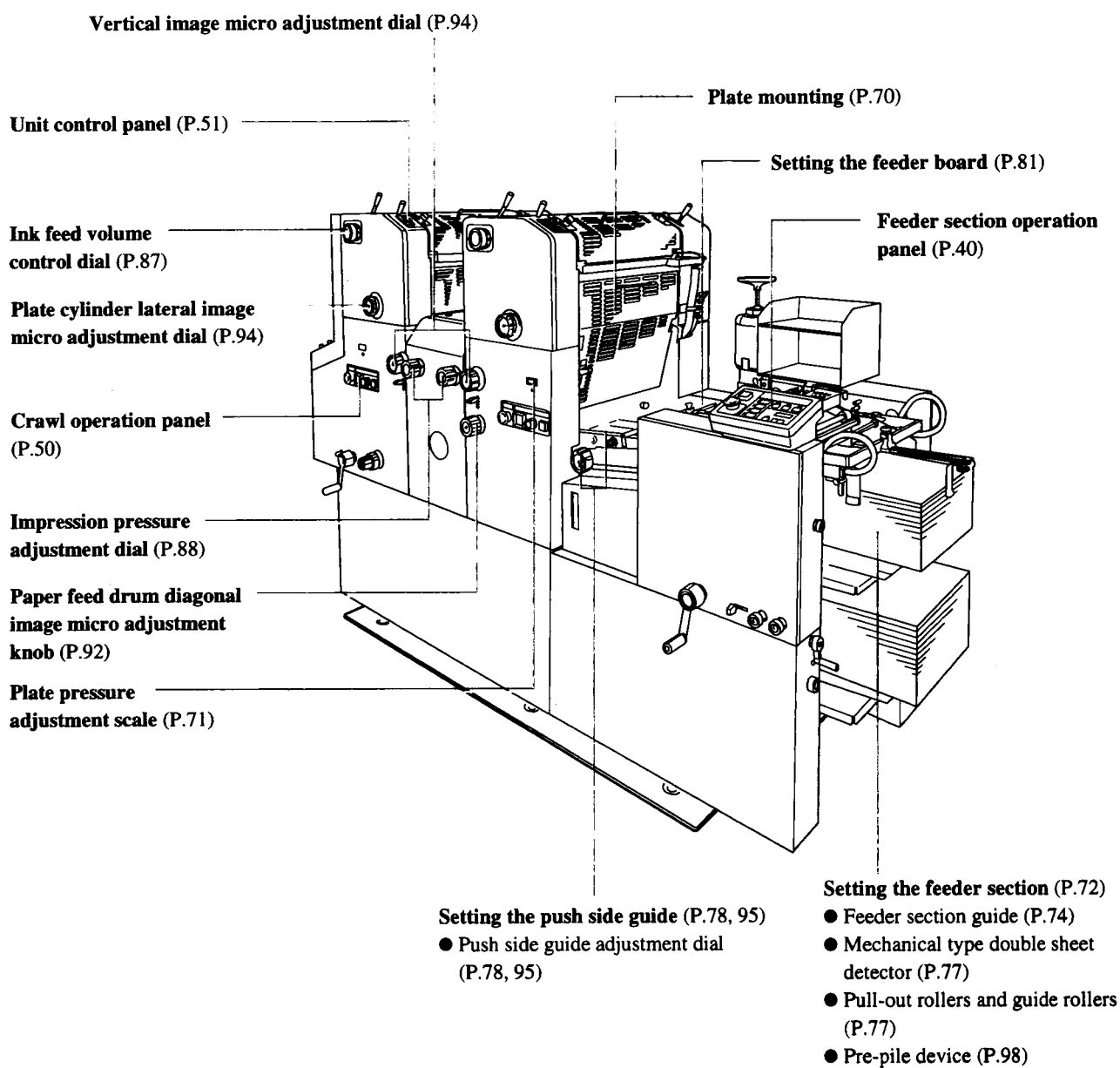



Setting the ink section (P.86)

Delivery section
operation panel (P.44)

Ink and water
operation panel (P.49)

Air pump
(P.132, 136, 140, 141)

Setting the powder spray device
(P.97)

Delivery section auxiliary
switch panel (P.52)

Setting the delivery
section (P.83)

Centralized oiling system (P.63)

[Important]

The machine maintenance and inspection are very important to keep the machine in top operation condition.

Please read the maintenance edition P. 111 through P. 148 carefully.

Safety Operation Edition

This edition explains about what you should pay careful attention to assure the safety.

Only operate the machine after understanding this edition fully.







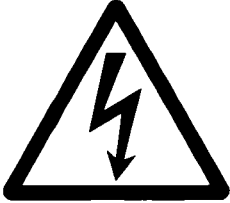
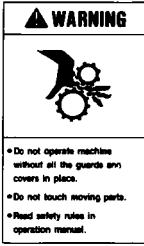

Read this edition fully to assure the safe operation.

Warning Labels

On this machine, we have applied warning labels at places where you should pay careful attention to assure the safety. Follow the instructions of the warning labels and pay careful attention to the safety.

■ Warning labels

No.	Picture indication	Title and meaning
①	 <p>Order number : 5290 61 135-1</p>	<p>Title : Danger of electric shock</p> <p>Meaning : When operating at the place that this label is applied, an electric shock causing death or grave injury may result if any part of your body touches it.</p>
②	 <p>Order number : 5290 74 087-2</p>	<p>Title : Warning of hands being caught in the machine</p> <p>Meaning : When operating at the place that this label is applied, failure to follow the instructions may result in a serious injury including your hands being caught in the machine.</p>
③	 <p>Order number : 5290 74 082-1</p>	<p>Title : Warning of hands being caught in the machine</p> <p>Meaning : When operating at the place that this label is applied, failure to follow the instructions may result in a serious injury including your hands being caught in the machine.</p>
④	 <p>Order number : 5290 74 083-2</p>	<p>Title : Caution of fingers being caught in the machine</p> <p>Meaning : When operating at the place that this label is applied, failure to follow the instructions may result in an injury including your fingers being caught in the machine.</p>
⑤	 <p>Order number : 5290 74 084</p>	<p>Title : Caution of fingers being caught in the machine</p> <p>Meaning : When operating at the place that this label is applied, failure to follow the instructions may result in an injury including your fingers being caught in the machine.</p>

No.	Picture indication	Title and meaning
⑥		<p>Title : Warning of electric shock</p> <p>Meaning : When operating at the place that this label is applied, an electric shock causing death or grave injury may result if any part of your body touches it.</p>
⑦		<p>Title : Caution of high temperature</p> <p>Meaning : When operating at the place that this label is applied, burns may result if any part of your body touches it.</p>
⑧		<p>Title : Caution of fingers being caught in the machine</p> <p>Meaning : When operating at the place that this label is applied, failure to follow the instructions may result in an injury including your fingers being caught in the machine.</p>

(Note) For the warning labels that do not have order numbers, please consult the dealer who you purchased the machine from.

■ Place to apply the warning labels

On this machine, the warning labels have been applied at the places shown in the illustration. Each number below and the ones shown on pages 13 and 14 are the same.

When any of these labels are damaged or peeled off, please clean or replace them with new ones. The labels that are replaced should be the same ones and applied at the same place. To order new labels, consult the dealer who you purchased the machine from.

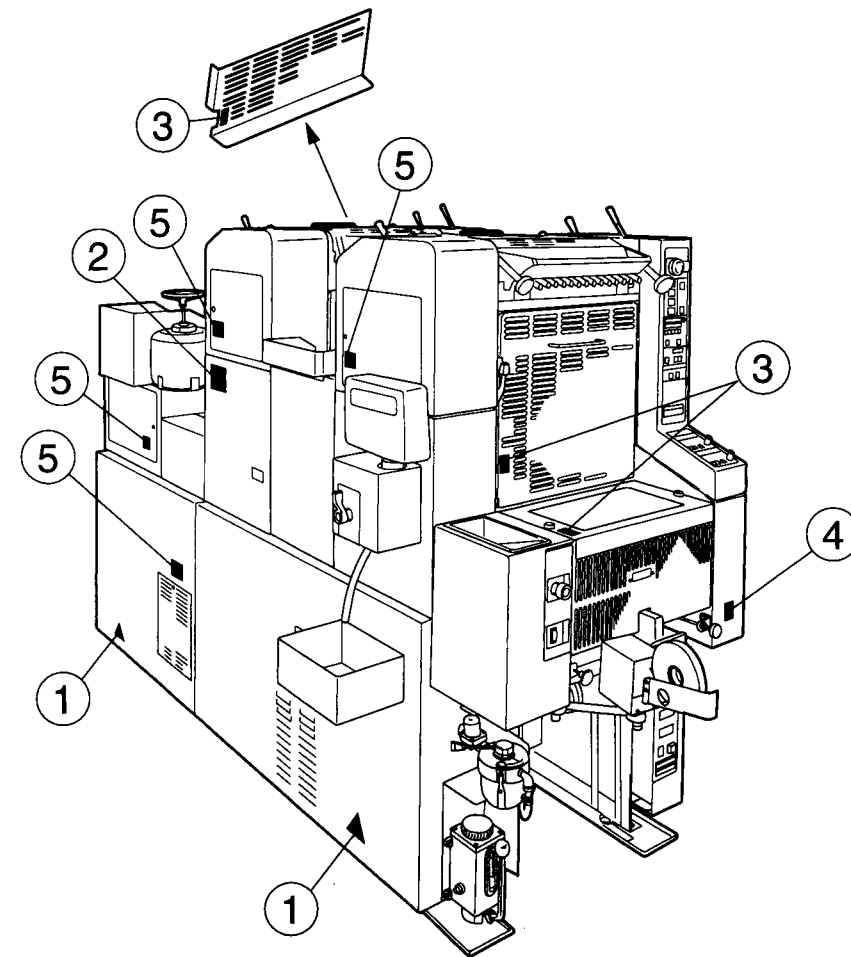
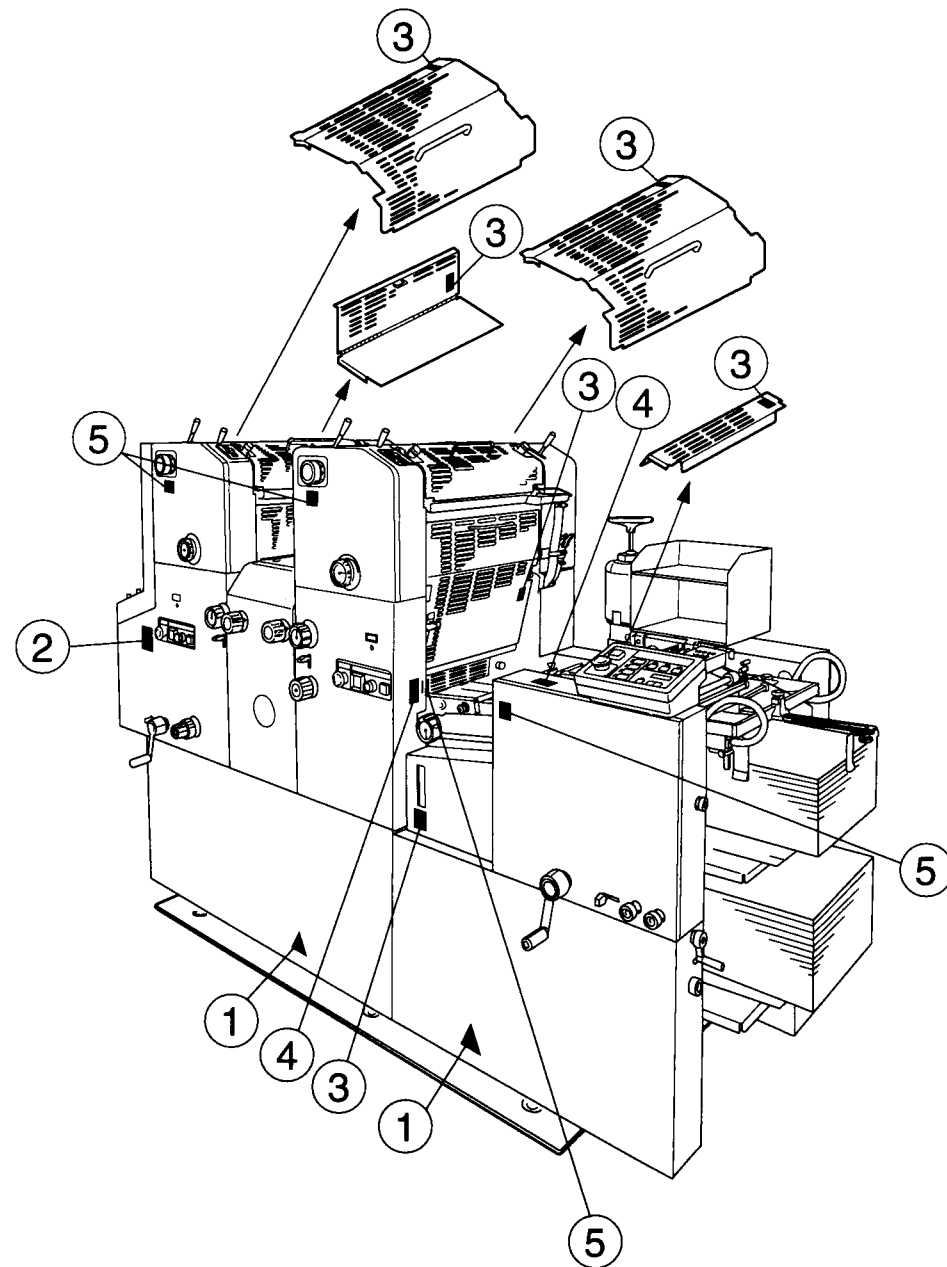



Precautions in the Operation Environment



DANGER

Use and storage of organic solvent

- On this machine, isopropyl alcohol and organic solvents, for example cleaning solution, are used. Never run the machine in a place that is air tight. Failure to follow this instruction may result in poisoning.
- Never bring a flame close to the organic solvent or any other combustibles. Failure to follow this instruction may result in a fire or explosion. Please position a fire extinguisher at a place that is readily accessible and easy to use.
- Never use an organic solvent and other chemicals for printing (the blanket cleaning solution and roller cleaner etc.) which have a flash point lower than 55°C (131°F).
- Use and store the organic solvent in a place with good ventilation.
- The organic solvent and other chemicals for printing contain harmful elements. Use them only after fully understanding the elements and handling instructions. When having questions, consult the store selling the organic solvent and other chemicals for printing to get a complete explanation.



Machine noise

This machine produces the following noise levels. Please set the operation environment based on the local ordinances.

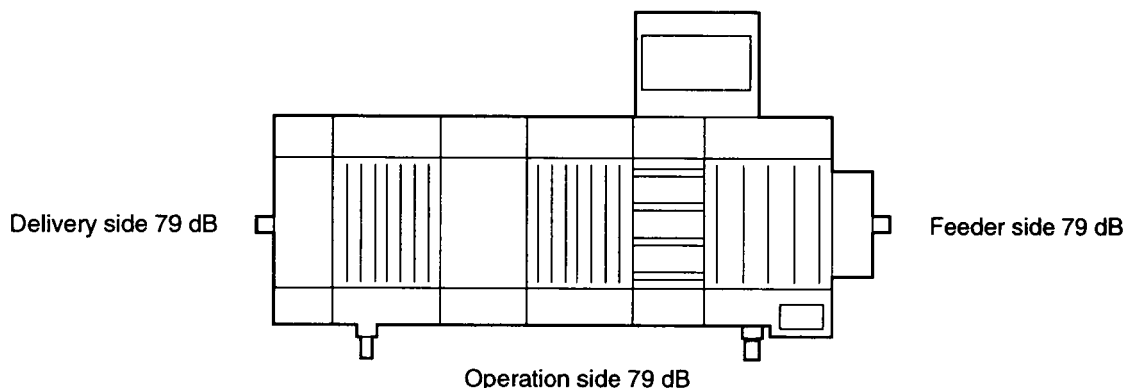

Measured by the DIN 45635 part 27.

Chapter 3

Precautions when Installing and Moving the Machine

■ Machine dimensions, weight, and power

<Installation>

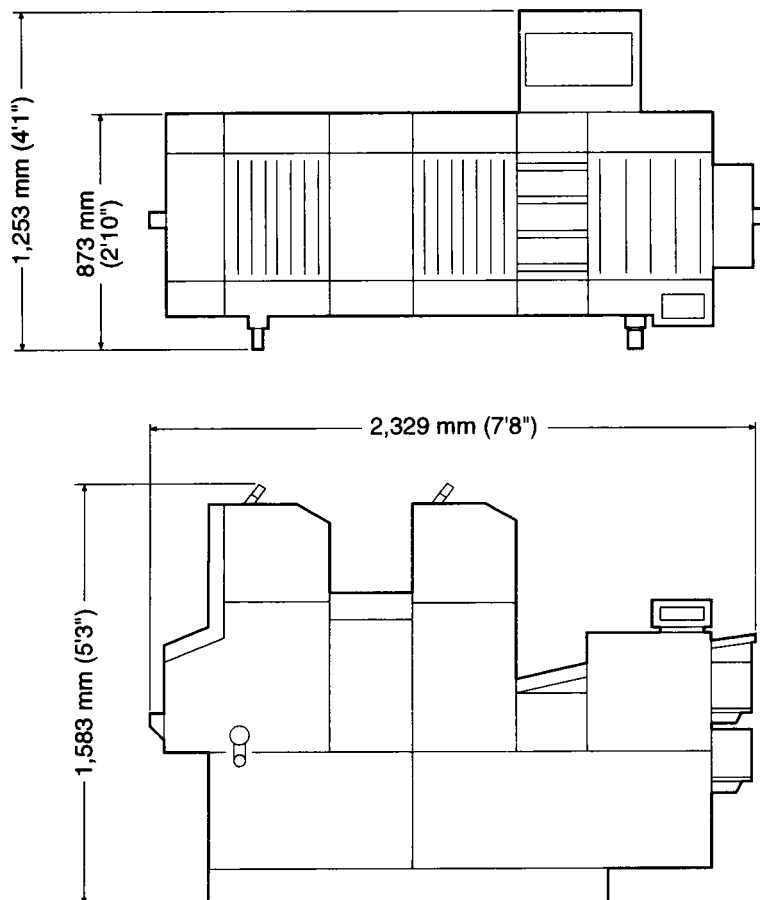

Weight	1,300 kg (2,866 lbs.)
Power	Single-phase, 208 V, 60 Hz, 12 A, Single-phase, 220 V, 50/60 Hz, 11.5 A or other voltages

■ Machine installing and moving

Installing (wiring and piping) and moving of the machine requires special knowledge and trained personnel to assure the machine performance and safety. So consult the dealer who you purchased the machine from. (The detailed information about the machine installing and moving is given in the service manual. So the service technician should follow the information given in the service manual.)

<Machine installation>

To assure the safe operation, install the device at the position as shown in the illustration. Check the machine and device position before doing the initial operation.

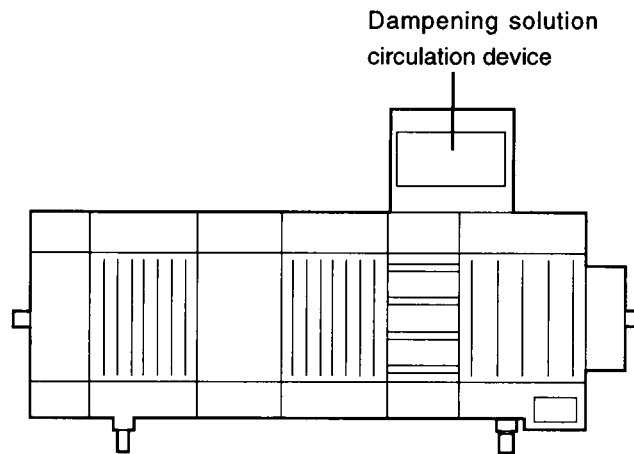

Precautions when Operating



WARNING

Preparation and procedures if an emergency happens!

- If finding poor operation of any safety cover, switch, and the other safety devices while running the machine, immediately stop the machine and consult the dealer who you purchased the machine from.
- If noticing a noise or offensive smell (burnt motor smell) while running the machine, stop the machine as soon as possible and follow the steps below.
 1. Turn off the power and pull out the power cord plug from the outlet.
 2. If needing to rotate the machine, do it manually by using the handwheel.
 3. Consult the dealer who you purchased the machine from.
- Prepare a fire extinguisher to extinguish any possible fire in the machine. Keep it at a place that is readily accessible and easy to use.

Fire extinguisher type

When a fire occurs in the machine or around the machine area, use the all purpose type fire extinguisher. (This type should be able to handle wood, paper, and fiber fires; grease and flammable liquids fires; and electrical component fire.)

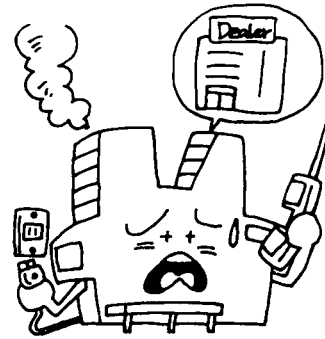

Cautions for clothes!

Never wear clothes or jewelry that may get easily caught in the machine when operating the machine. Set the long hair so that it does not get caught in the machine and wear a cap.

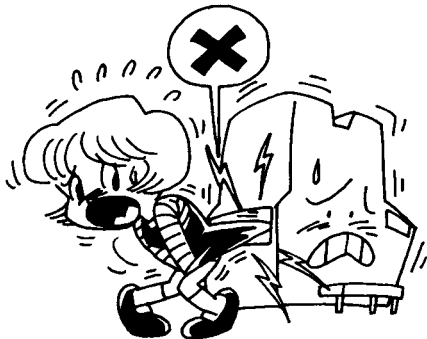

Failure to follow this instruction may result in a serious injury.

Mount the covers and safety devices properly!

Never alter the safety devices!

Mount the covers removed to do the maintenance, for example lubrication, in place and run the machine. Never remove or alter any safety device mounted on the machine.

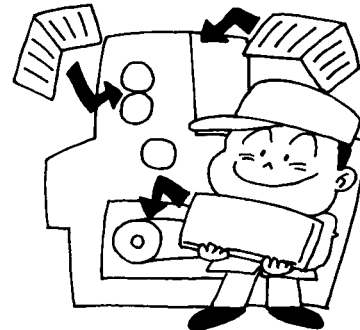

Failure to follow this instruction may result in a serious injury.



WARNING

Never “crawl” and “work” at the same time!

When doing the work with the “crawl operation”, for example cleaning the plate cylinder, blanket cylinder, impression cylinder, and water oscillating roller, never crawl and work at the same time.

Pushing the button and work should be done separately.



Failure to follow this instruction may result in a serious injury.

Mount the cylinder gap safety covers properly!

Mount the cylinder gap safety covers on the blanket cylinder and impression cylinder properly before running the machine.

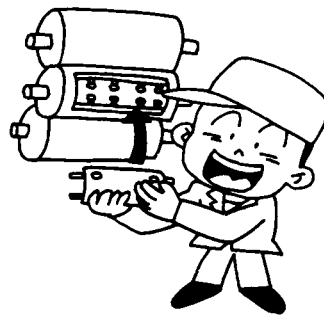

Failure to follow this instruction may result in a serious injury.

Be sure of what the other people are doing!

Pay attention to what work the others are doing when working with 2 or more people.

When you start to run the machine, first give them a signal. Only after receiving their signal or response, should you start the work.

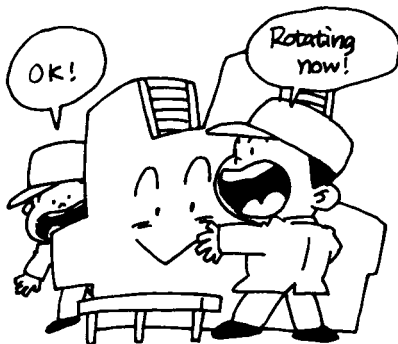

Failure to follow this instruction may result in a serious injury.

Never touch the rotating parts!

Never touch the rotating parts.

When foreign particles are on the plate cylinder and rollers, stop the machine before removing them.



Failure to follow this instruction may result in a serious injury.



WARNING

Stop the machine before doing the setting around the rotating parts! (in the delivery section)

Push the emergency stop button to stop the machine before doing the setting around the rotating parts, such as the air blower, spray nozzle, and rotary guide.



Failure to follow this instruction may result in a serious injury.

Never insert your hand inside when pulling out a sheet!

Never insert your hand inside the machine when pulling out sample sheets. Pick up the sheet edge using your fingers and pull it out quickly.

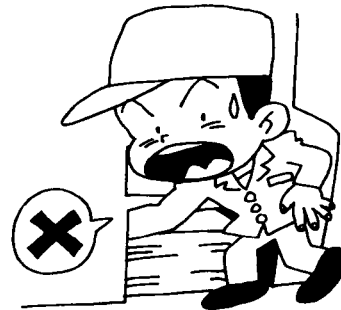

Failure to follow this instruction may result in a serious injury.



CAUTION

Never touch the electrical parts with wet hands!

Never do with wet hands, the plugging in or unplugging of the machine power cord plug or any connecting plug, turning the power switch ON or OFF, and handling any other electrical parts.

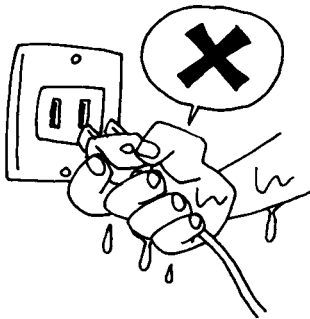

Failure to follow this instruction may result in an electric shock.

Keep the area around the machine clean!

Never leave any tools on the floor. Never allow oil and grease to collect on the floor. Keep the area around the machine clean.



Failure to follow this instruction may result in an injury.

Never use broken tools!

Replace any worn out or broken tools with new ones.

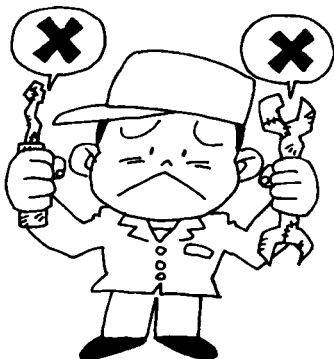

Failure to follow this instruction may result in an injury.

Never put your hand on the feeder pile while it is rising!

Never put your hand on the top surface of the feeder pile, while it is rising.

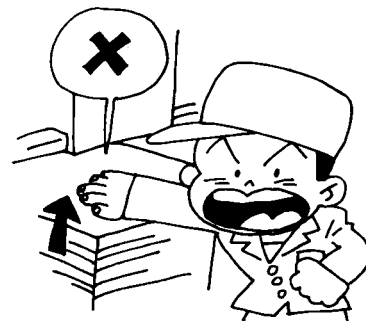

Failure to follow this instruction may result in an injury.



CAUTION

**Stop the machine before doing the setting around the rotating parts!
(in the feeder section)**

Stop the machine before doing the setting around the rotating parts, such as the suction feet and sheet separator bracket.

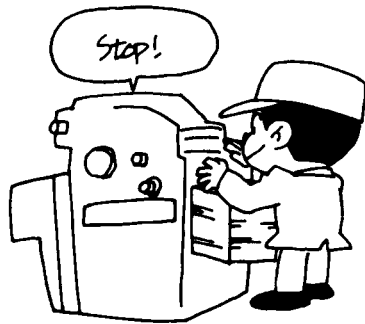

Failure to follow this instruction may result in an injury.

**Stop the machine before doing the setting around the rotating parts!
(on the feeder board)**

Stop the machine before doing the setting the feeder board, such as the mechanical type double sheet detector, pull-out roller, guide roller, retainer, board tape, and push side guide.



Failure to follow this instruction may result in an injury.

Precautions when Doing Maintenance



WARNING

Turn off the power before doing the lubrication and maintenance!

Turn off the power before doing the manual lubrication and maintenance.

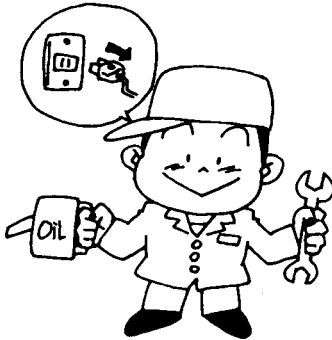

Failure to follow this instruction may result in a serious injury.

Mount the covers and safety devices properly!

Never alter the safety devices!

Mount the covers removed to do the maintenance, for example lubrication, in place and then run the machine. Never remove or alter any safety device mounted on the machine.

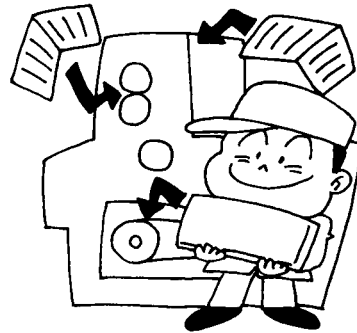

Failure to follow this instruction may result in a serious injury.

Stop the rotation before cleaning the cylinders and rollers!

Stop the crawl operation before doing the maintenance and cleaning of the plate cylinder, blanket cylinder, impression cylinder, and rollers.

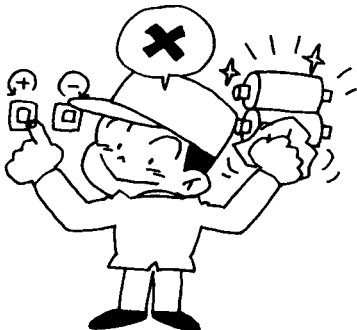

Failure to follow this instruction may result in a serious injury.

Wear safety goggles before supplying or replacing the chemicals!

Wear safety goggles to protect your eyes before supplying or replacing the organic compound solvent or chemicals for printing.



Failure to follow this instruction may result in losing your eyesight.



WARNING

Wear safety goggles before using the air gun!

Wear safety goggles to protect your eyes before doing the maintenance and cleaning using the air gun.



Failure to follow this instruction may result in losing your eyesight.



CAUTION

Adjustment and maintenance that should be done by the operator!

The adjustment of the ink and water roller pressure, adjustment of the feeder section, checking the air pump, checking the dampening solution circulation device, and lubrication following the lubrication chart are the adjustments and maintenance listed in the operation manual that should be done by the operator.

All other adjustments and maintenance should be done by the service technician who has special knowledge and technical expertise through training, so consult the dealer who you purchased the machine from.

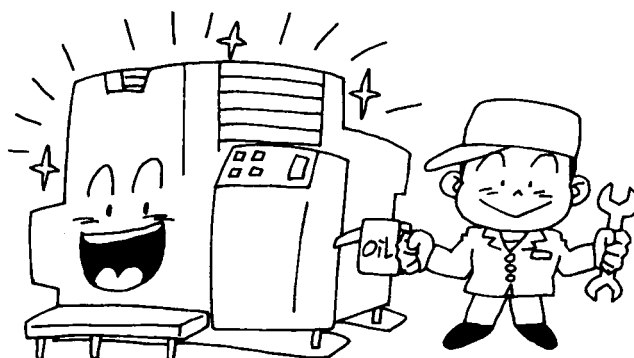

Turn off the power before cleaning the static eliminator!

Turn off the power before cleaning the static eliminator electrode.

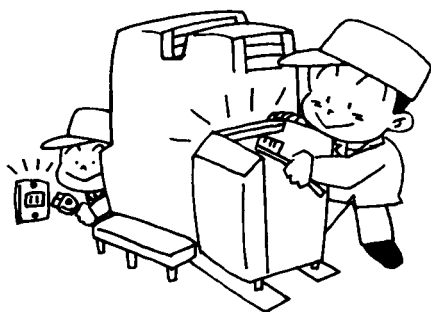

Failure to follow this instruction may result in an electric shock.

Never replace any parts other than the consumables!

Never replace any parts other than the consumables shown in the maintenance edition "Chapter 4 Replacing the Supplies" in this manual.

The replacement should be done by a service technician who has special knowledge and technical expertise through training, so consult the dealer who you purchased the machine from.

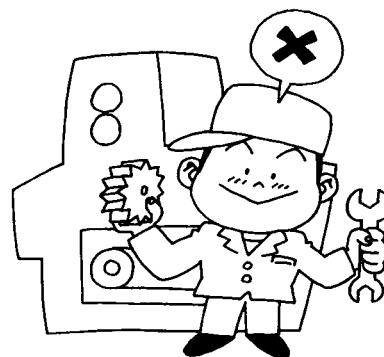

Failure to follow this instruction may result in an injury.

Chapter 6

Safety Device



WARNING

When a safety device is not functioning properly, consult the dealer who you purchased the machine from. Never remove or alter the safety devices.

■ Safety device operation indication

When a safety device actuates, the monitor indication lamp lights on the delivery section operation panel and it informs the operator which safety device actuates.

To assure safety, when a safety device actuates, the machine cannot be run.

A. When the safety devices (1) through (10) in the illustration actuate, the machine cannot be run and crawled.

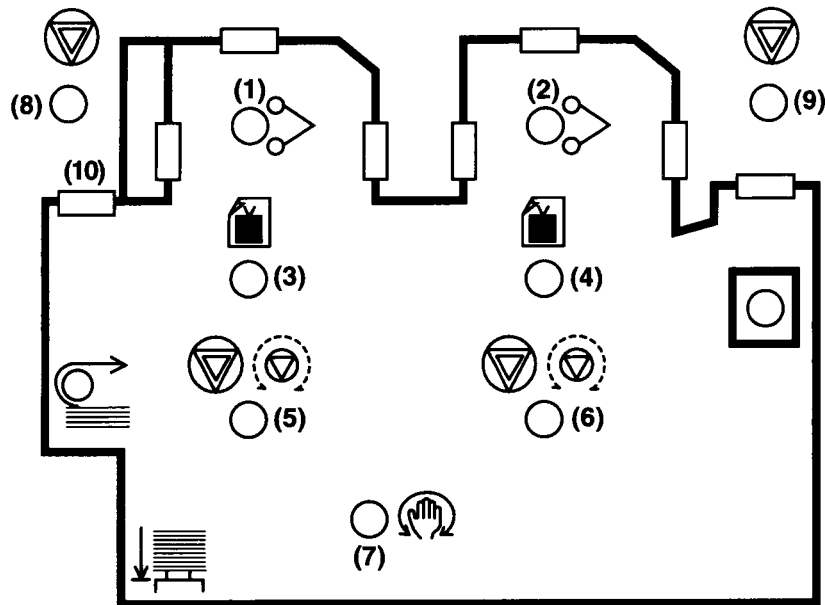

Sign	Name	Sign	Name
	Emergency stop button		Safety bar
	Crawl ON/OFF button		Handwheel mounting door
	Safety cover, Door		Vertical image micro adjustment device

B. There are a limited number of covers that can be open and crawl operation (3m/min. and 1m/min.) can be done at the same time with the crawl ON/OFF button pushed. When opening any other cover, the crawl operation cannot be done.

When all of the covers are closed, the crawl operation speed is 3m/min.

- ... The crawl ON/OFF button that is pushed.
- ... Crawl operation (3m/min.) can be done even with the cover open.
- ... Crawl operation (1m/min.) can be done even with the cover open.

When pushing the crawl ON/OFF button on the first unit crawl operation panel

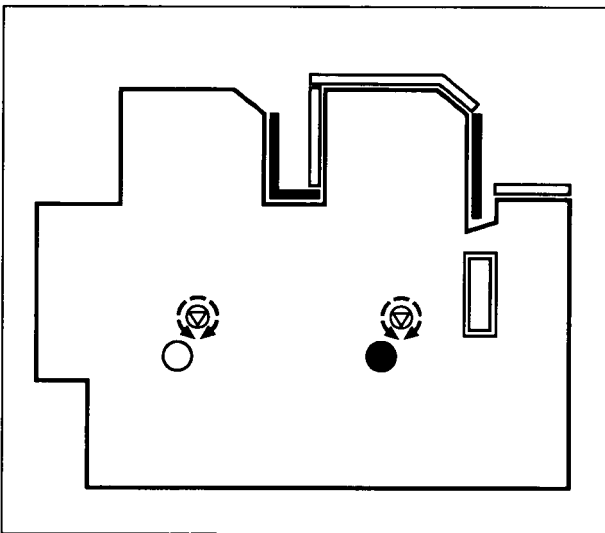

When pushing the crawl ON/OFF button on the second unit crawl operation panel

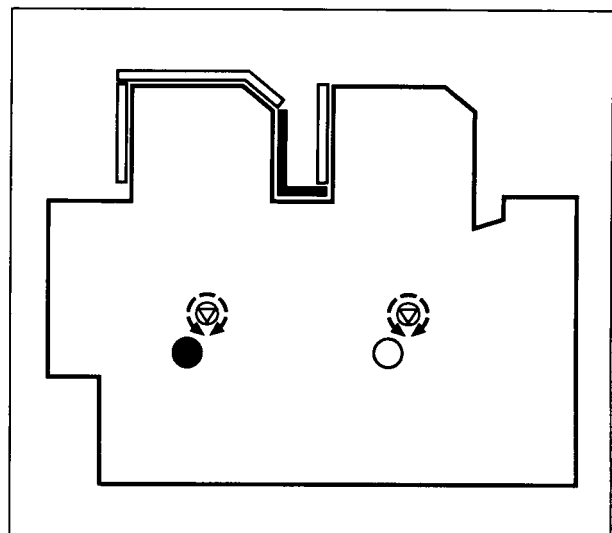

■ Safety device function explanation

Emergency stop button

When pushing this button, the machine will stop and the button will lock. In this condition, the machine cannot be run and crawled. When turning the button in the direction of the arrow, the lock will be released and the machine can be run and crawled.

The emergency stop buttons are located on the feeder section operation panel, crawl operation panel (first and second units), and delivery section operation panel.

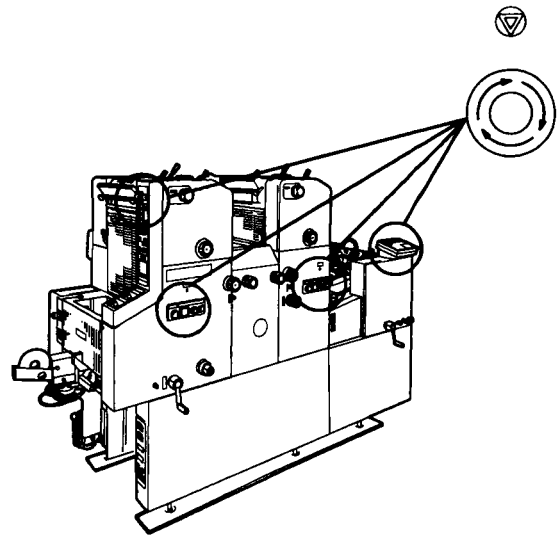

Crawl ON/OFF button

When pushing this button, the machine will stop and the button will lock. In this condition, the machine cannot be run but crawl operation can be done. When turning the button in the direction of the arrow, the lock will be released and the machine can be run.

The crawl ON/OFF button is located on the crawl operation panel (first and second units).

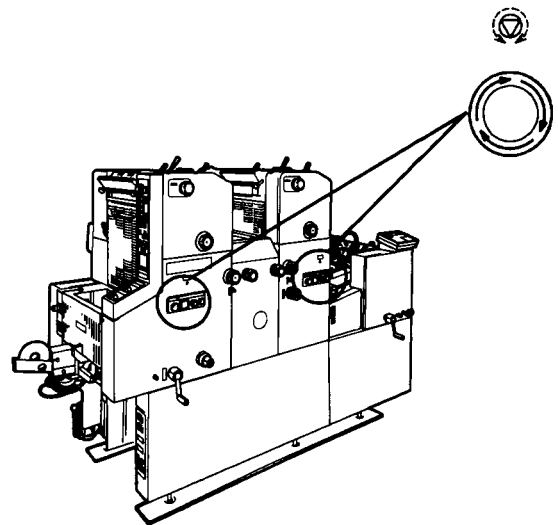

Machine cover, safety cover, and door

The machine covers, safety covers, and door cover the operating section and rotating parts of the machine to protect the operator from the danger of being caught in the machine.

When opening the safety cover or door, the machine cannot be run. Also when opening the delivery section safety cover, the machine cannot be run or crawled.

Mount the covers removed to do the maintenance in place after finishing the maintenance.

— : Safety cover

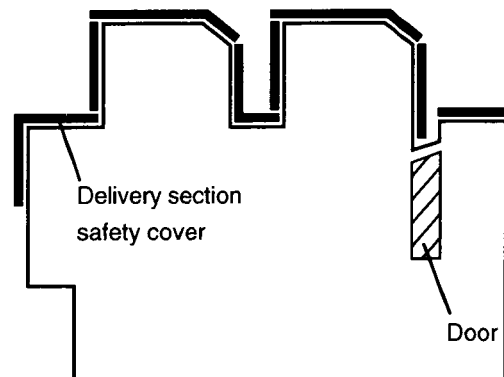

Safety bar

The safety bars are mounted to protect the fingers and rags from the danger of being caught in the machine, when doing work on the plate cylinder, blanket cylinder, impression cylinder, and parts around them while they are rotating.

When a safety bar actuates, the machine will stop immediately and the machine cannot be run and crawled.

When the safety bar is reset in the former position, the machine can be run and crawled.

The safety bars are located at the positions shown in the illustration below.

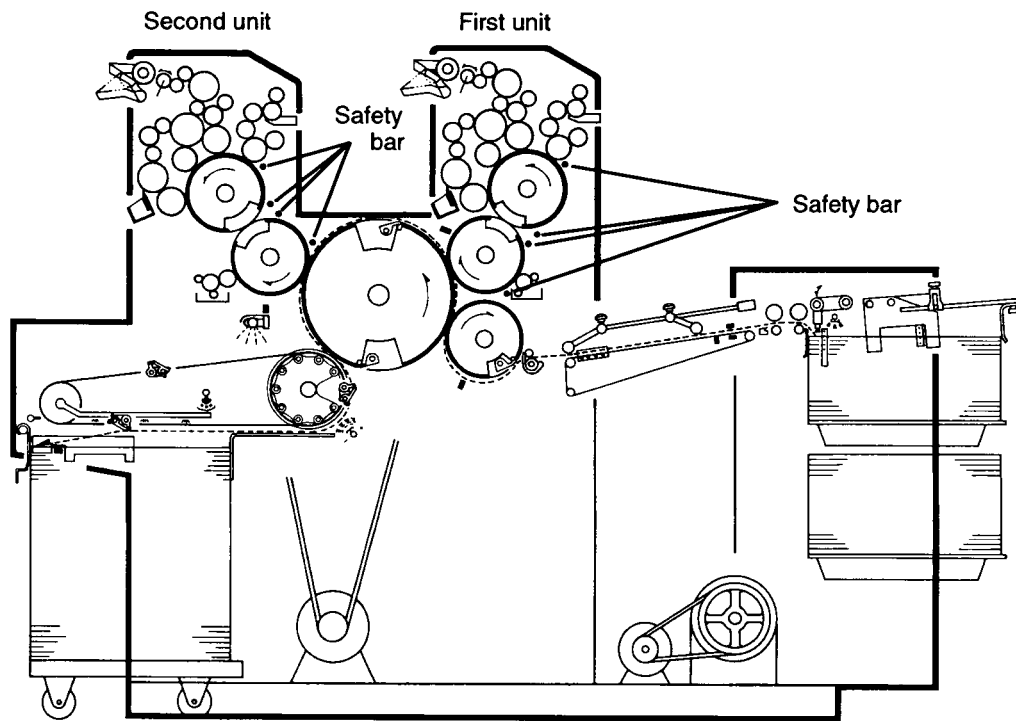

Handwheel mounting door

The safety device of the handwheel mounting door is mounted to assure the operator's safety when mounting the handwheel and rotating the cylinders manually.

When opening the handwheel mounting door, the safety device actuates and the machine cannot be run and crawled. When closing the handwheel mounting door, the machine can be run and crawled.

The handwheel mounting door is located at the position shown in the illustration on the right.

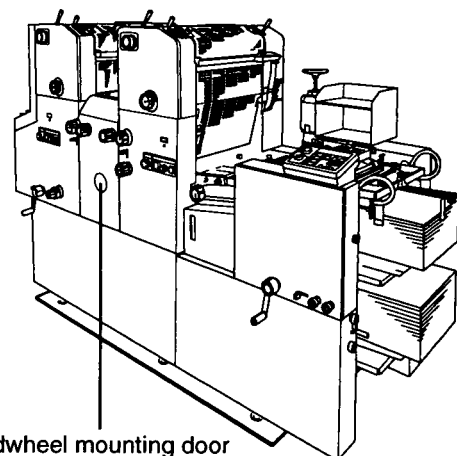

Handwheel mounting door

Introduction Edition

This edition is composed of Chapter 1 “Machine Outline” and Chapter 2 “Name and Function of Each Part”.



Machine Outline

1-1 Specifications

Number of Printing Units	2
Max. Paper Size (W x L)	340 x 450 mm (13.39 x 17.72")
Min. Paper Size (W x L)	90 x 100 mm (3.54 x 3.94")
Paper Thickness	0.04 - 0.3 mm (0.016 - 0.012")
Max. Printing Area (W x L)	330 x 438 mm (12.99 x 17.24")
Printing Speed	3,000 - 10,000 SPH The local conditions, ink, stock, and printing plate types, and printing quality required will affect the maximum printing speed.
Plate Size	335 x 485 mm (13.19 x 19.09")
Plate Clamp Type	Straight-edge plate clamp with positioning pins (spring-tension system)
Blanket Type	Blanket with aluminum bar
Blanket Size	344 x 488 x 1.9 mm (13.54 x 19.21 x 0.075")
Under Blanket Size	330 x 447 x 0.6 mm (12.99 x 17.60 x 0.024")
Feeding System	Universal feeder
Feeder Pile Capacity	Height : 440 mm (17.32"), Weight : 90 kg (198 lbs.)
Feeder Pile System	Pre-pile
Delivery System	Chain delivery
Delivery Pile Capacity	Height : 440 mm (17.32"), Weight : 90 kg (198 lbs.)
Registration System	Push side guide
Infeed System	Paper feed drum
Number of Rollers	Ink rollers : 16 (form rollers : 3) Water rollers : 6 (form roller : 1)
Dampening System	Continuous dampening system
Gripper Margin	8 mm (0.31")
Vertical Image Adjustment	± 20 mm (± 0.79")
Lateral Image Adjustment	± 2.0 mm (± 0.079")
Oiling System	Centralized oiling system
Power	Single-phase, 208 V, 60 Hz, 12 A, Single-phase, 220 V, 50/60 Hz, 11.5 A or other voltages
Power Consumption	2 kW
Motor Wattage	Main motor : 1.5 kW Paper feed pump motor : 550 W
Dimensions (L x W x H)	2,329 x 873 x 1,583 mm (7'8" x 2'10" x 5'3")
Net Weight	1,300 kg (2,866 lbs.)

*Design and specifications are subject to change without notice.
Specifications may slightly differ depending on the country.*

<Optional accessories>

The following items are optional accessories.

The operation of the optional accessories (1) through (6) is explained in this manual. For the explanation of the other optional accessories, please see each individual instruction manual.

- (1) Dampening solution cooling/circulation device (P.157)
- (2) PCS-F printing control system (P.162)
- (3) Blanket cleaning device (P.184)
- (4) Double sheet detector (Electronic type) (P.43, 47)
- (5) Multi-size paper pile board (P.72)
- (6) Print counter (total number of printed sheets, 8-digit, non-resettable) (P.52)
- (7) Exclusive parts for envelopes
- (8) Tape inserter
- (9) RP520-220F high-precision register punch

1-2 Mechanical Layout

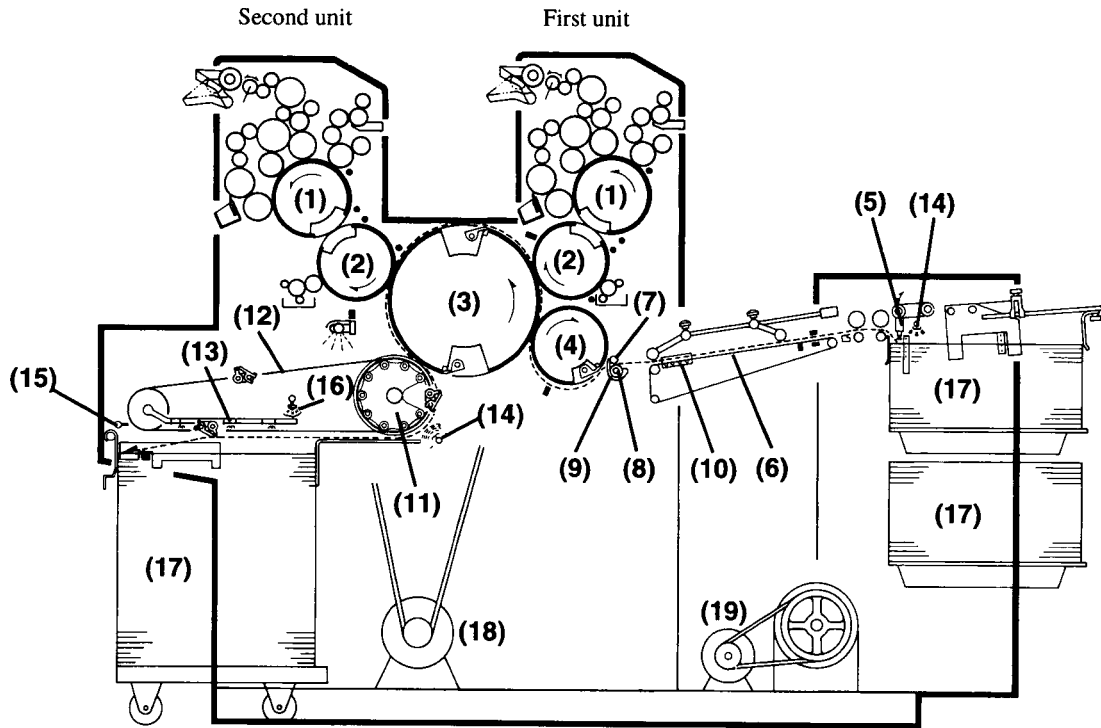

No.	Name	No.	Name
1	Plate cylinder	11	Rotary guide
2	Blanket cylinder	12	Chain delivery
3	Double diameter impression cylinder	13	Air blower
4	Paper feed drum	14	Static eliminator electrode
5	Suction foot	15	Delivery jam detector
6	Feeder board	16	Powder spray device
7	Upper feed roller	17	Printing sheet
8	Lower feed roller	18	Main motor
9	Stop finger	19	Pump
10	Push side guide		

1-3 Roller Arrangement

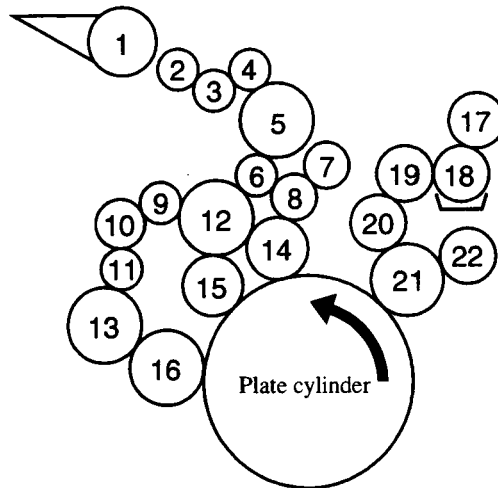

No.	Roller name	Outer diameter mm (inch)	Effective length mm (inch)	Material (JIS rubber hardness)	Part number
1	Ink fountain roller	50 (1.969")	345 (13.58")	Stainless	5340 51 831-1 (with PCS-F 5344 66 311)
2	Ink ductor roller	31 (1.220")	333 (13.11")	Rubber (25°)	5340 51 140
3	Ink first roller	28.5 (1.122")	333 (13.11")	Rilsan	5322 51 310-1
4	Ink distributor roller	34 (1.339")	335 (13.19")	Rubber (35°)	5340 51 570
5	Ink rider oscillating roller	63 (2.480")	346 (13.62")	Rilsan	5322 51 610-2
6	Ink distributor roller	34 (1.339")	335 (13.19")	Rubber (35°)	5340 51 550
7	Ink distributor roller (Bridge roller)	34 (1.339")	327 (12.87")	Rubber (35°)	5340 51 560-1
8	Ink distributor roller	40 (1.575")	333 (13.11")	Rilsan	5340 51 510-2
9	Ink distributor roller	34 (1.339")	335 (13.19")	Rubber (35°)	5340 51 550
10	Ink rider oscillating roller	40 (1.575")	333 (13.11")	Rilsan	5341 53 610-1
11	Ink distributor roller	34 (1.339")	335 (13.19")	Rubber (35°)	5340 51 550
12	Ink oscillating roller	69.64 (2.742")	340 (13.39")	Rilsan	5341 51 410-2
13	Ink oscillating roller	69.64 (2.742")	340 (13.39")	Rilsan	5341 51 410-2
14	Ink first form roller	61.5 (2.421")	335 (13.19")	Rubber (30°)	5340 51 700
15	Ink second form roller	56 (2.205")	335 (13.19")	Rubber (30°)	5322 51 700
16	Ink third form roller	65 (2.559")	335 (13.19")	Rubber (30°)	5322 51 810
17	Squeeze roller	46 (1.811")	396 (15.59")	Rubber (30°)	5344 53 220
18	Water fountain roller	48 (1.890")	396 (15.59")	Chrome plated	5344 53 111-2
19	Metering roller	46 (1.811")	396 (15.59")	Rubber (20°)	5344 53 330
20	Water oscillating roller	42 (1.654")	351 (13.82")	Chrome plated	5344 53 611
21	Water form roller	65.4 (2.575")	340 (13.39")	Rubber (20°)	5344 53 530
22	Water rider oscillating roller	45 (1.772")	353 (13.90")	Rilsan	5344 53 440-1

Please be sure to consult the parts list when ordering rollers.

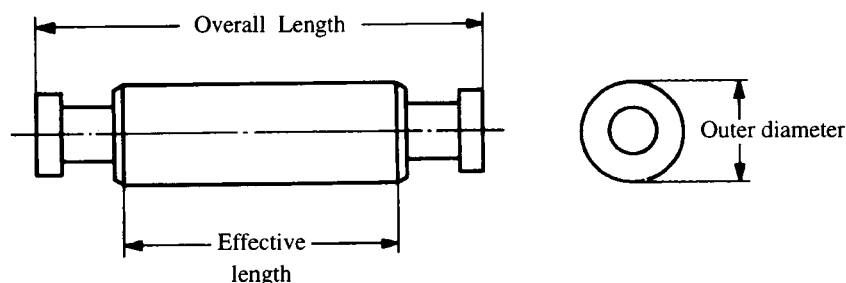

1-4 Cylinder Packing and Plate and Blanket Size

1) Plate Packing and Plate Size

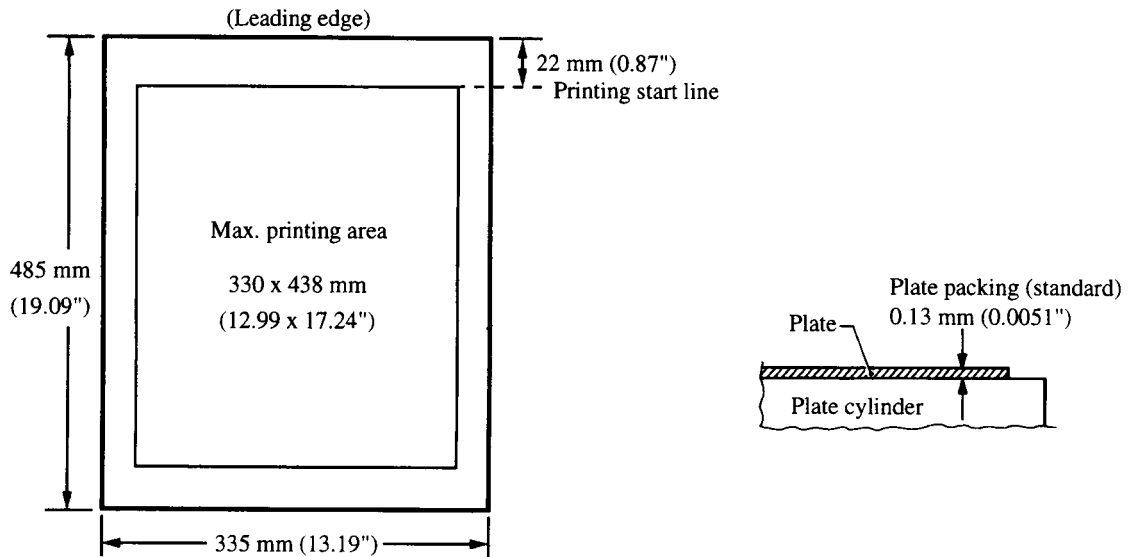

(Reference) The 0.13 mm (0.0051") packing thickness is the standard thickness. However, the pressure between the plate cylinder and blanket cylinder is adjusted by the plate pressure adjustment scale. So, a plate with a thickness from 0.1 mm (0.004") to 0.3 mm (0.012") can be used.

2) Blanket Packing and Blanket/Under Blanket Size

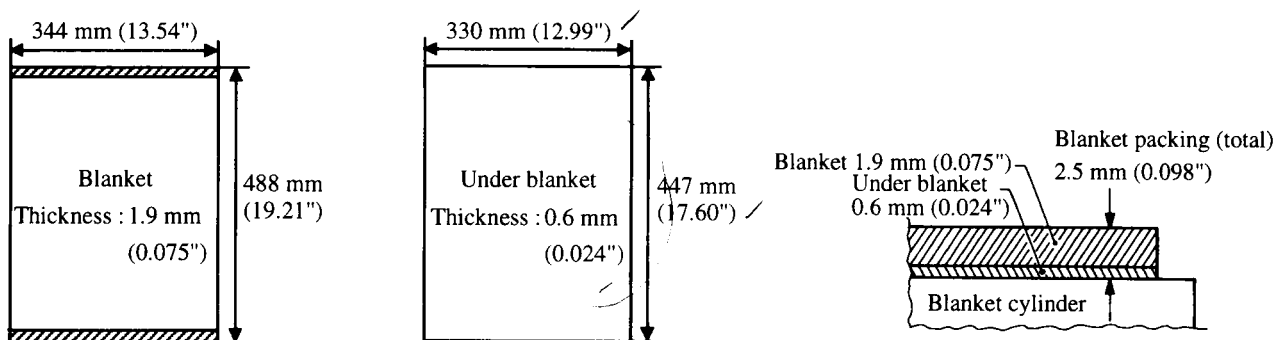







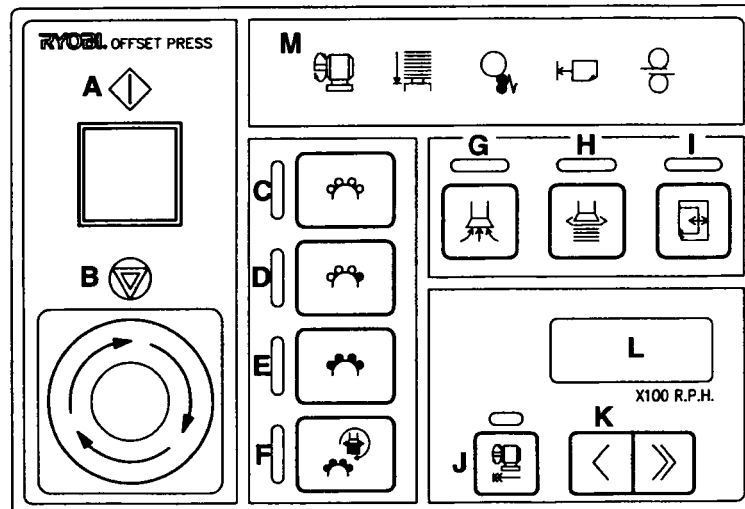

Names and Functions

For the explanation about the symbols for the operation switches, please read this chapter carefully. They are designed following the DIN 30600 (symbols).

2-1 Feeder Section Operation Panel



Push button switch

- A.  Drive button**
When pushing this button, the machine starts.
- B.  Emergency stop button**
When pushing this button, the machine will stop and the button will lock. In this condition, the machine cannot be run and also crawl operation cannot be done. When turning the button in the direction of the arrow, the lock will be released and the machine can be run and crawled.
- C.  Water and ink form roller OFF button**
When pushing this button, the lamp will light. Both the water form roller and ink form roller will separate from the plate surface to stop the supply of the dampening solution and ink.
- D.  Water form roller ON button**
When pushing this button, the lamp will light. Each roller in the water section will contact. Finally the water form roller will contact the plate surface to supply the dampening solution.
- E.  Water and ink form roller ON button**
When pushing this button, the lamp will light. First each roller in the water section will contact and then water form roller will contact the plate surface to supply the dampening solution. After that, the ink form roller will contact the plate surface to supply the ink.
- F.  Printing start button**
When pushing this button, the lamp will light. The water form roller and ink form roller in this order will contact the plate surface to supply the dampening solution and ink. After that, the pump operates and the paper feed and printing starts automatically.
When the set speed drive button lamp goes off and pushing this button, printing starts in the metal plate printing mode.
When the set speed drive button lamp lights and pushing this button, printing starts in the polyester plate printing mode.
- G.  Pump button**
When pushing this button, the lamp will light and the pump will operate. When pushing this button again, the lamp will go off and the pump will stop.
(Note) Until the last sheet of paper fed reaches the delivery pile, the pump will not stop to prevent a delivery jam from occurring.
- H.  Paper feed button**
When pushing this button, the lamp will light and the feeder will start. When pushing this button again, the lamp will go off and the feeder will stop.

I.  Paper size change button

When pushing this button, the lamp will light and feed only one sheet of paper. When the sheet fed reaches the stop finger, the lamp will go off automatically and the machine will stop. And when pushing this button again, the lamp will light and feed the sheet up to the delivery section. When the sheet fed reaches the delivery section, the lamp will go off automatically and the machine will stop.

(Note) This function is only available while the machine is running.

J.  Set speed drive button



When pushing this button while the machine is running, the lamp will light and the machine accelerates to the speed set on the speed indication panel.

When pushing this button again, the lamp will go off and the machine returns to 3,000 RPH.

Use this button when adjusting the feeder section or cleaning the rollers.

And also, when pushing this button, the plate printing mode is changed over to either the metal plate printing mode (The lamp is off.) or polyester plate printing mode (The lamp is ON.). Then push the printing start button to start printing.

K.  Speed set button

When pushing the  button, the printing speed will be reduced and when pushing the  button, the printing speed will be increased.

When pushing the  buttons at the same time, the printing speed is set to 7,000 RPH.

L. Speed indication

This indicates the printing speed of the machine.

M. Monitor indication

(P.43)

[Printing mode matching each plate material]

2 different printing modes are available (one for metal plates and the other for polyester plates) to be chosen for the proper printing start condition for either a metal plate or a polyester plate.

Operation and process in the metal plate printing mode

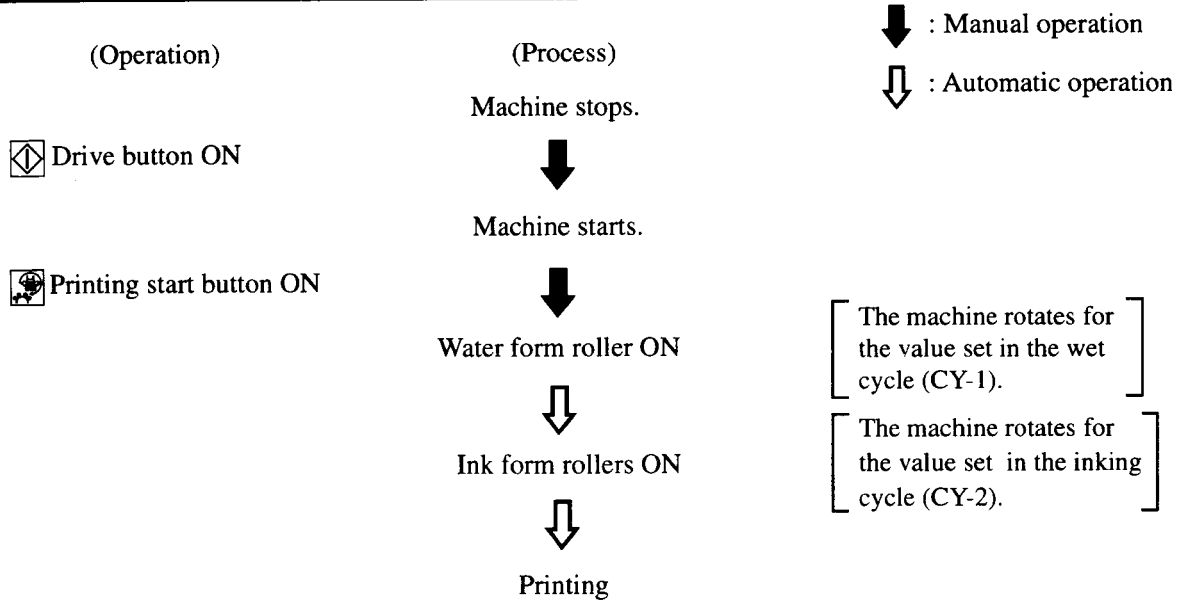

Operation and process in the polyester plate printing mode

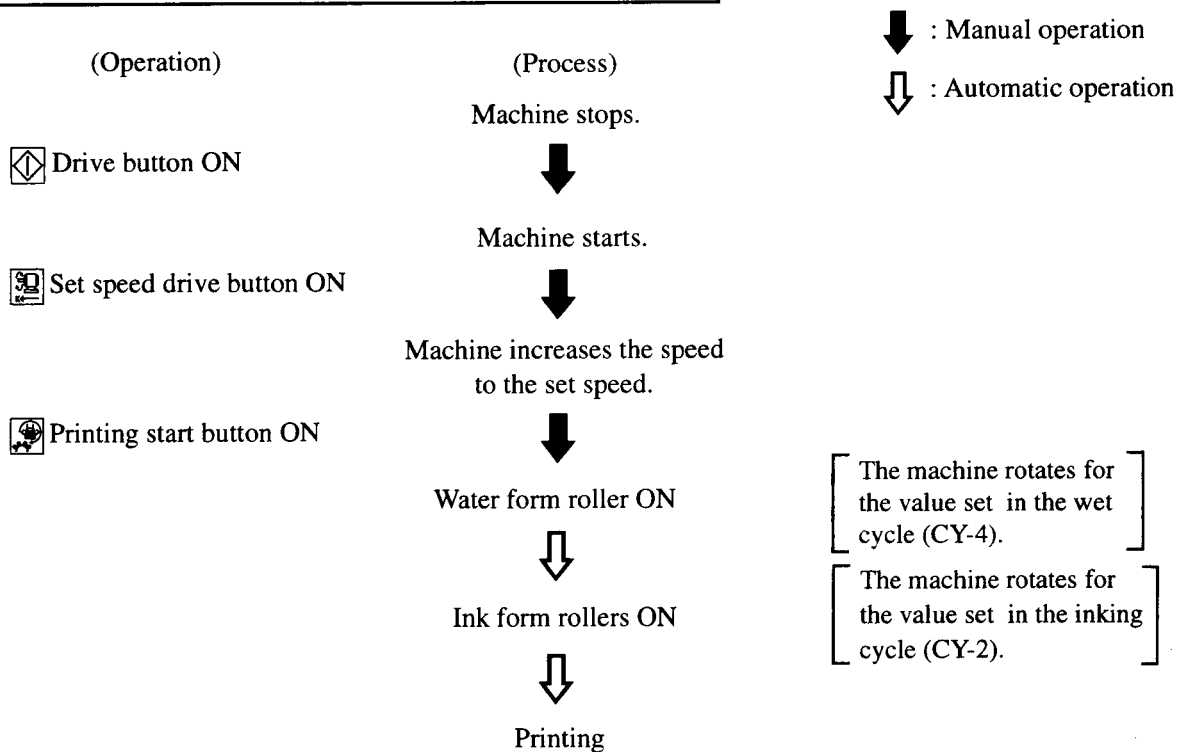

(Reference) For the cycle setting (CY-1, CY-2, and CY-4), please refer to the page 89.

Monitor indication

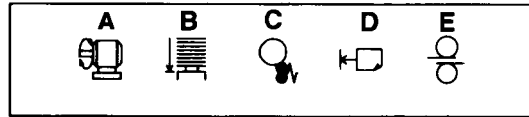

A. Drive lamp

When this lamp lights, the machine can be run. If any safety cover is open or any safety device is actuated, the lamp will go off and the machine cannot be run.

When a paper feed jam is detected, the lamp will go off. In this case only when pushing the drive button while the lamp is off, the machine can be run.

B. Delivery table dolly lower limit detector lamp

When the delivery pile is full, the feeder will stop and the lamp will light.

C. Paper feed jam detector lamp

● Infeed jam detector function

When paper feed trouble occurs on the feeder board or paper feed drum, the machine will stop. At this time, a buzzer will sound and the lamp will light to inform the operator.

● Cylinder ON sensor jam detector function

During 1 rotation of the cylinder after the paper passes over the cylinder ON sensor, if the paper is still on the sensor, the machine will stop due to the gripper transfer trouble. At this time, a buzzer will sound and the lamp will light to inform the operator.

After removing the paper on the feeder board or on the paper guide (1) under the paper feed drum and when pushing the paper feed button again, the lamp will go off.

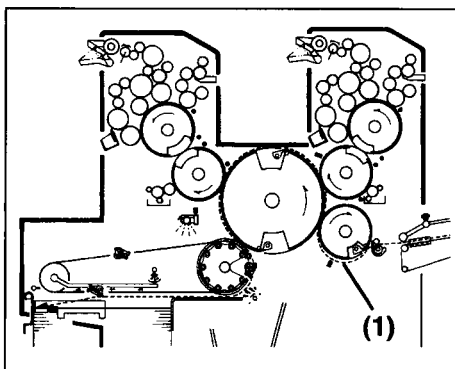

D. Paper feed break detector lamp

When a break in the paper feed occurs due to poor suction, the paper feed will stop. At this time, a buzzer will sound and the lamp will light to inform the operator.

After removing the paper on the feeder board and when pushing the paper feed button again, the lamp will go off.

E. Double sheet detector lamp

● Electronic type double sheet detector function

When the first sheet thickness is more than 1 mm (0.039") or the electronic type double sheet detector detects double sheets, the paper feed will stop. And after starting the paper feed, when the detector cannot memorize the sheet thickness automatically even after third sheet is fed, the paper feed will stop. At this time, a buzzer will sound and the lamp will light to inform the operator.

● Mechanical type double sheet detector function

When the mechanical type double sheet detector detects double sheets, the paper feed will stop.

At this time, a buzzer will sound and the lamp will flicker to inform the operator.

Remove the double sheets on the feeder board. Push the paper feed button again, and the electronic type double sheet detector will memorize the second or third sheet thickness automatically and then the lamp will go off.

2-2 Delivery Section Operation Panel

Push button

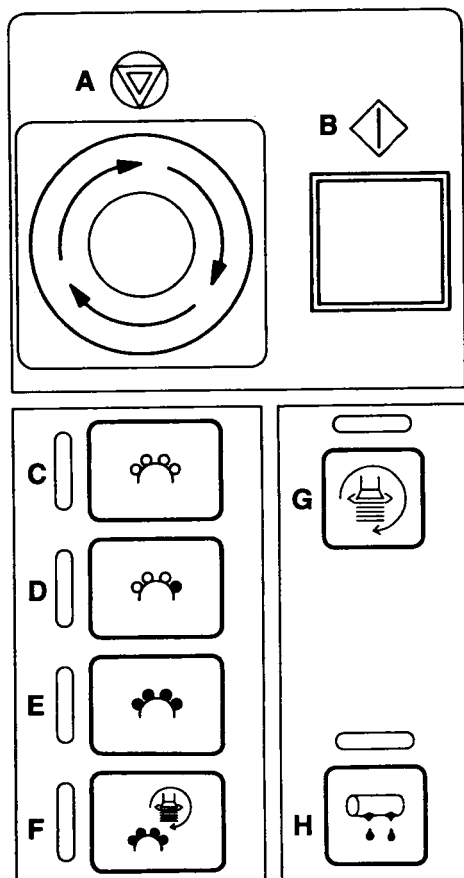

A. Emergency stop button

When pushing this button, the machine will stop and the button will lock. In this condition, the machine cannot be run and also crawl operation cannot be done. When turning the button in the direction of the arrow, the lock will be released and the machine can be run and crawled.

B. Drive button

When pushing this button, the machine starts.

C. Water and ink form roller OFF button

When pushing this button, the lamp will light. Both the water form roller and ink form roller will separate from the plate surface to stop the supply of the dampening solution and ink.

D. Water form roller ON button

When pushing this button, the lamp will light. Each roller in the water section will contact. Finally the water form roller will contact the plate surface to supply the dampening solution.

E. Water and ink form roller ON button

When pushing this button, the lamp will light. First each roller in the water section will contact and then water form roller will contact the plate surface to supply the dampening solution. After that, the ink form roller will contact the plate surface to supply the ink.

F. Printing start button

When pushing this button, the lamp will light. The water form roller and ink form roller in this order will contact the plate surface to supply the dampening solution and ink. After that, the pump operates and the paper feed and printing starts automatically.

When the set speed drive button lamp goes off and pushing this button, printing starts in the metal plate printing mode.

When the set speed drive button lamp lights and pushing this button, printing starts in the polyester plate printing mode.

G. Production button

When pushing this button, the lamp will light and the vacuum pump and suction feet will operate and then feed the paper. When pushing this button again, the lamp will go off and the paper feed will stop. And when the last sheet of paper fed reaches the delivery pile, the pump will stop.

When pushing this button during the printing, the paper feed and pump will stop. At the same time, the water form roller and ink form roller will separate from the plate surface.

H. Blanket cleaning button

This button is used on the machine with the blanket cleaning device. (P.184)

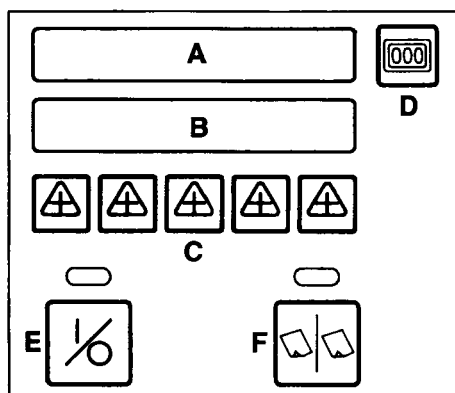
Counter panel**A. Sheet counter**

It shows the number of sheets printed.
(Additional type)

B. Set counter

In the **preset repeat counter mode**, it indicates the set number of sheets to be printed.

In the **batch separation mode**, it indicates the number of sheets per batch and during the printing, the indicated number will be subtracted.

C. Counter set button

When pushing any one of the buttons, the number indicated on the set counter will change. Push each button to set the number of printed sheets or batch number of sheets required.

When pushing both side set buttons at the same time, the set counter indication will be reset to "0".

D. Counter clear button

When pushing this button, the sheet counter indication will be reset to "0".

E. Counter ON/OFF button

When pushing this button, the lamp will light and the count will start.

When pushing this button again, the lamp will go off and the count will stop.

F. Mode selection button

To select the **preset repeat counter mode** (The lamp is off.) or **batch separation mode** (The lamp lights.), push this button.

In the **preset repeat counter mode**, when the number indicated on the sheet counter display matches the number on the set counter display, the buzzer sounds and the paper feed will stop.

In the **batch separation mode**, when the number on the set counter display indicates "20" and "0", the buzzer sounds.

Speed set / indication panel

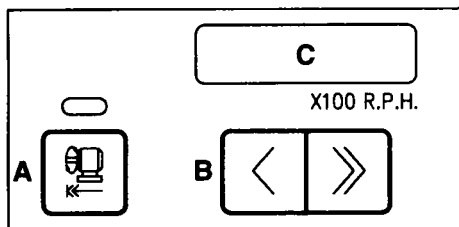

A.  Set speed drive button



When pushing this button while the machine is running, the lamp will light and the machine accelerates to the speed set on the speed indication panel.

When pushing this button again, the lamp will go off and the machine returns to 3,000 RPH.

Use this button when adjusting the feeder section or cleaning the rollers.

And also, when pushing this button, the plate printing mode is changed over to either the metal plate printing mode (The lamp is off.) or polyester plate printing mode (The lamp is ON.). Then push the printing start button to start printing.

B.  Speed set button

When pushing the  button, the printing speed will be reduced and when pushing the  button, the printing speed will be increased.

When pushing the  buttons at the same time, the printing speed is set to 7,000 RPH.

C. Speed indication

This indicates the printing speed of the machine.

Unit selection panel

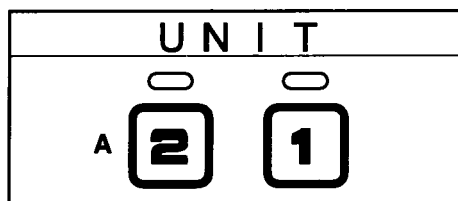

A. Unit selection button

When pushing the button with the unit number which printing will be done, the lamp will light indicating that it is possible to print on that unit.

Monitor indication

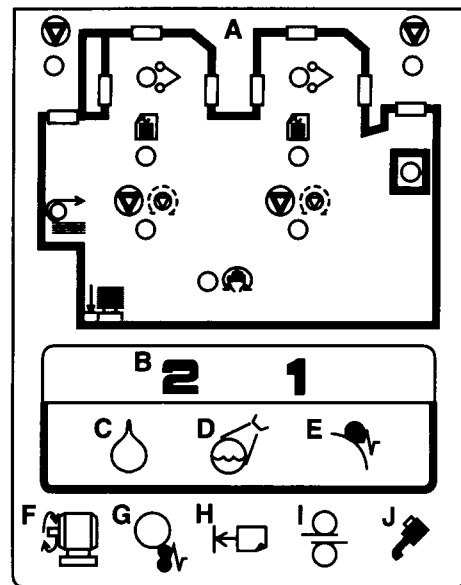

(Note) When more than 2 conditions in C through E in the previous column occur, the trouble will be indicated by one lamp lighted and the other lamp flickering. When this occurs, first correct the trouble indicated by the lamp that lights. After that correction, the lamp that is flickering will change to lighting continuously. Correct the trouble indicated by that lamp.

A. Safety device indication

(P. 28)

B. Unit indication lamp

When the dampening solution in the water fountain is not at the proper level, the water roller cleaning lever is at the position, or a blanket jam occurs, the lamp for that unit will light.

C. Water warning lamp

When the dampening solution in the water fountain on the first unit or second unit is not at the proper level, this lamp will light.

When this lamp lights, the metering roller will not rotate. Also the paper feed button cannot go on.

When supplying the dampening solution into the water fountain, the lamp will go off.

D. Water roller cleaning lever ON detector lamp

When the water roller cleaning lever is at the position on the first unit or second unit, this lamp will light.

When this lamp lights, printing cannot be done. When setting the water roller cleaning lever at the position, the lamp will go off.

E. Blanket jam detector lamp

When a sheet of paper is jammed on the blanket on the first unit or second unit, the machine will stop. At this time, a buzzer will sound and the lamp will light to inform the operator. After removing the jammed paper, the lamp will go off.

Example)

● **If the trouble following occurs, . . .**

First unit ... The dampening solution in the water fountain is not at the proper level.

Second unit ... The water roller cleaning lever is at the position.

The dampening solution in the water fountain is not at the proper level.

Trouble	Unit No.	
	2	1
The water roller cleaning lever is at the position.	○	
The dampening solution in the water fountain is not at the proper level.	○	○

● **Lamp indication and trouble correcting procedures**

... Light ... Flicker

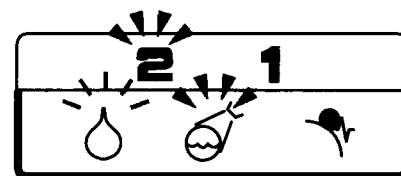

Set the water roller cleaning lever on the second unit at the position.

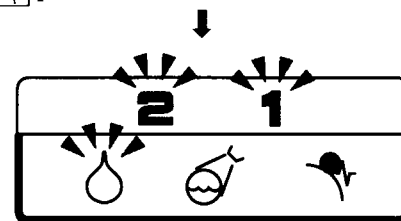

Supply the dampening solution into the water fountain on the first unit and second unit to the proper level.

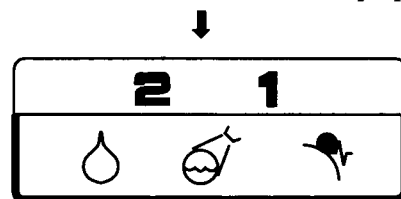

Complete.

F. Drive lamp

When this lamp lights, the machine can be run. If any safety cover is open or any safety device is actuated, the lamp will go off and the machine cannot be run.

G. Paper feed jam detector lamp

● **Infeed jam detector function**

When paper feed trouble occurs on the feeder board or paper feed drum, the machine will stop. At this time, a buzzer will sound and the lamp will light to inform the operator.

● **Cylinder ON sensor jam detector function**

During 1 rotation of the cylinder after the paper passes over the cylinder ON sensor, if the paper is still on the sensor, the machine will stop due to the gripper transfer trouble. At this time, a buzzer will sound and the lamp will light to inform the operator.

After removing the paper on the feeder board or on the paper guide (1) under the paper feed drum and when pushing the paper feed button again, the lamp will go off.

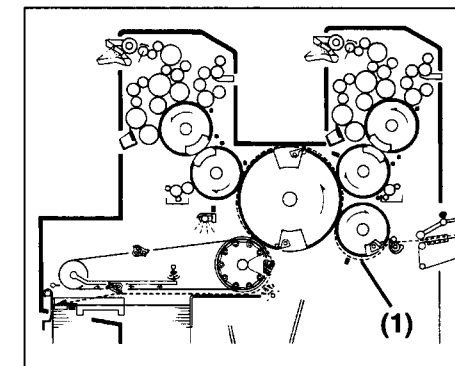

H. Paper feed break detector lamp

When a break in the paper feed occurs due to poor suction, the paper feed will stop. At this time, a buzzer will sound and the lamp will light to inform the operator.

After removing the paper on the feeder board and when pushing the paper feed button again, the lamp will go off.

I. Double sheet detector lamp

● **Electronic type double sheet detector function**

When the first sheet thickness is more than 1mm (0.039") or the electronic type double sheet detector detects double sheets, the paper feed will stop. And after starting the paper feed, when the detector cannot memorize the sheet thickness automatically even after third sheet is fed, the paper feed will stop. At this time, a buzzer will sound and the lamp will light to inform the operator.

● **Mechanical type double sheet detector function**

When the mechanical type double sheet detector detects double sheets, the paper feed will stop. At this time, a buzzer will sound and the lamp will flicker to inform the operator.

Remove the double sheets on the feeder board. Push the paper feed button again, and the electronic type double sheet detector will memorize the second or third sheet thickness automatically and then the lamp will go off.

J. Oil warning lamp

The lamp will light once every 500,000 rotations. Lubricate each section following the lubrication chart.

When pushing the oil warning reset button on the delivery section auxiliary switch panel, the lamp will go off.



2-3 Ink and Water Operation Panel

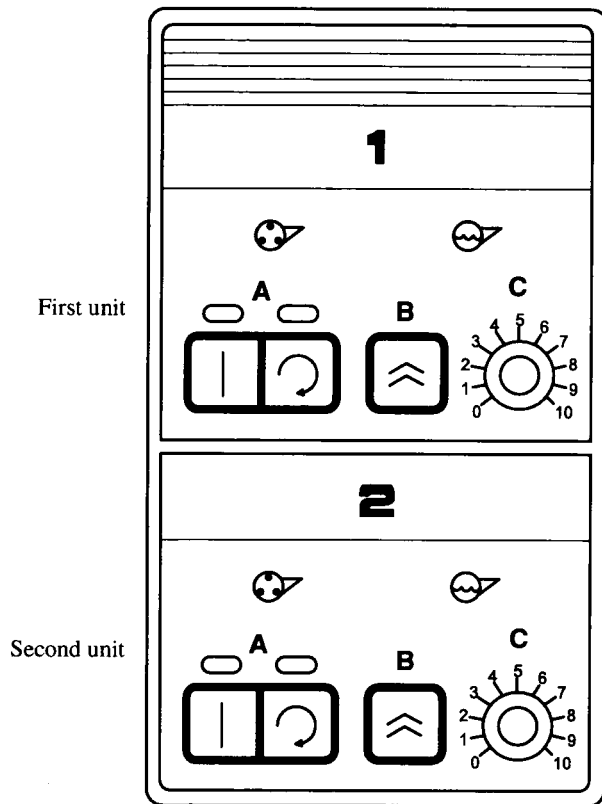



A. Ink ductor button

 (Automatic) ... When pushing this button, the lamp will light. The ink ductor only operates during the printing and supplies the ink.

When pushing this button again, the lamp will go off. The ink ductor stops and no ink is supplied.

 (ON) When pushing this button, the lamp will light. When running the machine, the ink ductor always operates and the ink is supplied.

When pushing this button again, the lamp will go off. The ink ductor stops and no ink is supplied.

When starting the printing, the  lamp will go off automatically and the  lamp will light automatically.

B. Dampening speed up button

While pushing this button, the dampening solution supply volume is increased. When releasing this button, the supply volume returns to that set by the dial. During the printing, scumming caused by a lack of dampening solution on the plate surface can be corrected quickly.

C. Water volume control dial

When turning it toward a larger number on the dial scale, the dampening solution supply volume is increased.

2-4 Crawl Operation Panel

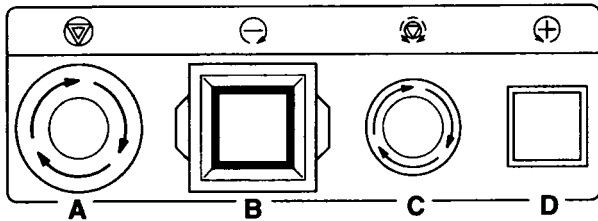

A. Emergency stop button
When pushing this button, the machine will stop and the button will lock. In this condition, the machine cannot be run and also crawl operation cannot be done. When turning the button in the direction of the arrow, the lock will be released and the machine can be run and crawled.

B. Reverse crawl button

WARNING
Never touch the rotating parts when doing the crawl operation. Failure to follow this instruction may result in a serious injury.

When pushing this button with the crawl ON/OFF button on this panel locked, the machine will crawl in the reverse direction.

There are 2 different kinds of crawl operation speed (3 m/min. and 1 m/min.). (P.29)

C. Crawl ON/OFF button
When pushing this button, the machine will stop and the button will lock. In this condition, the crawl operation can be done. When turning the button in the direction of the arrow, the lock will be released and the machine can be run.

D. Forward crawl button

WARNING
Never touch the rotating parts when doing the crawl operation. Failure to follow this instruction may result in a serious injury.

When pushing this button with the crawl ON/OFF button on this panel locked, the machine will crawl in the forward direction.

There are 2 different kinds of crawl operation speed (3 m/min. and 1 m/min.). (P.29)

Crawl ON/OFF button and crawl button

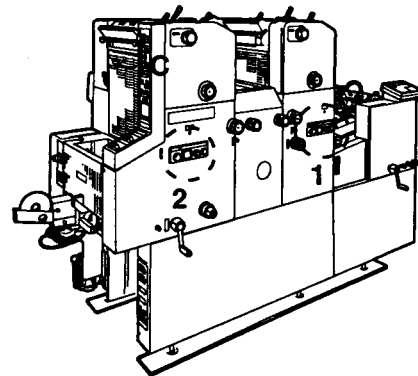

WARNING
Never touch the rotating parts when doing the crawl operation. Failure to follow this instruction may result in a serious injury.

- The crawl ON/OFF button and crawl button are located at the 2 places marked 1 and 2. The crawl operation is possible when the crawl ON/OFF button on each panel is pushed. When pushing the crawl ON/OFF button, the lamp will light.
 - While lighted The crawl operation can be done.
 - While flickering .. The crawl operation cannot be done.

(2 crawl ON/OFF buttons are pushed or a safety device is actuated.)
- While OFF The crawl operation cannot be done.

Plate cylinder predetermined position stop function

With the drive lamp lighted, when pushing the (forward/reverse) crawl button 1 or 2 shown in the illustration, the machine crawls and stops automatically at the plate mounting/removal position.

Crawl button	Plate cylinder stop position
1	Position where it is easy to mount a plate on the first unit
	Position where it is easy to remove a plate on the first unit
2	Position where it is easy to mount a plate on the second unit
	Position where it is easy to remove a plate on the second unit

2-5 Unit Control Panel

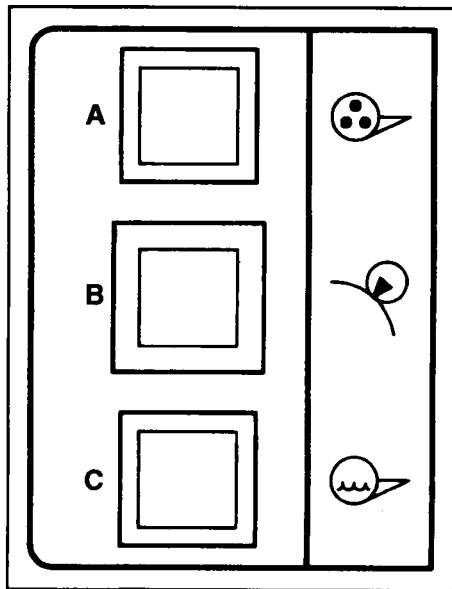

A.  Ink ductor manual ON button

While pushing this button, the ink ductor roller will rotate. When releasing it, the ink ductor roller will stop rotating. Use this button when supplying ink to the rollers before starting printing.

B.  Plate hold-down button

When pushing this button, the water form roller contacts only the plate surface. (The water form roller will not contact the water oscillating roller.) When pushing this button again, the water form roller will release from the plate surface. Use this button when mounting the plate on the plate cylinder.

C.  Water roller crawl button

While pushing this button, the crawl operation of the metering roller, water fountain roller, and squeeze roller can be done. Use this button when doing the maintenance of each roller.

2-6 Delivery Section Auxiliary Switch Panel

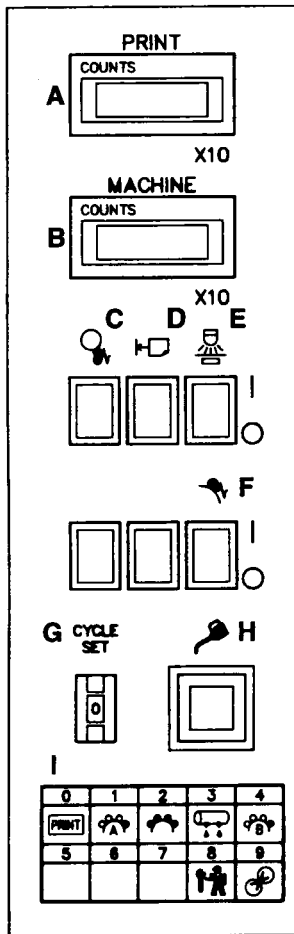

A. Print counter

This shows the total number of sheets printed from the initial operation. This counter counts each sheet of paper fed through the machine whether it is printed or not.

B. Machine counter

This shows the total number of the cylinder rotations.

C. Paper feed jam detector switch

This is the ON/OFF switch of the paper feed jam detector which stops the machine when sheet travel trouble on the feeder board occurs.

(ON) The device will operate.

(OFF) The device will not operate.

D. Paper feed break detector switch

This is the ON/OFF switch of the paper feed break detector which stops the paper feed when a paper feed break occurs.

(ON) The device will operate.

(OFF) The device will not operate.

E. Electronic type double sheet detector switch

When printing on the porous paper, turn the switch OFF (position) and only use the mechanical type double sheet detector.

<< NOTICE >>

Be sure to use the mechanical type double sheet detector when printing with the electronic type double sheet detector switch at the position.

If printing is done without either double sheet detector (mechanical or electronic) used, the machine may be damaged.

F. Blanket jam detector switch

This is the ON/OFF switch of the blanket jam detector that stops the machine when a sheet of paper jams on any blanket cylinder on the first or second unit.

(ON) The device will operate.

(OFF) The device will not operate.

G. Cycle set button







Use this when setting each process cycle during the printing or when doing the maintenance and inspection. (P. 89, 119)

H. Oil warning reset button

When the oil warning lamp lights on the delivery section operation panel, lubricate the required places on the machine, then push this button. The lamp will go off.

I. Cycle set indication panel

The cycle number of each process and contents set by the cycle set button (G) are indicated by the symbols.

Cycle number and symbol	Cycle process
0 	Set at this position when printing.
1 	Wet cycle of the water form roller for the metal plate printing mode
2 	Inking cycle
3 	Blanket cleaning cycle (Note) This is used on the machine with the blanket cleaning device.
4 	Wet cycle of the water form roller for the polyester plate printing mode
8 	Only service technicians use this.
9 	Set at this position when doing the roller and cylinder pressure adjustment.

(Note) There are no functions for the cycle numbers from 5 to 7.

2-7 Paper Feed Section

1) Feeder pile

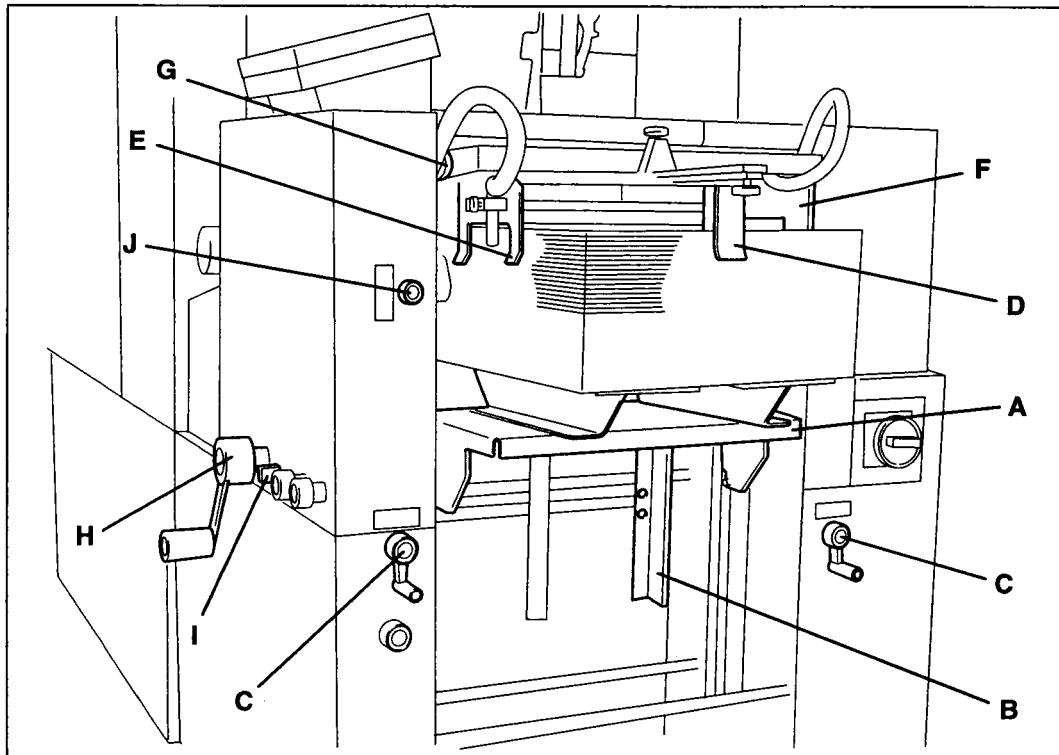

A. Paper feed table

Pile the paper on this table.

B. Vertical guide

When piling the paper, pile it straight following this guide.

C. Vertical guide handle

This handle is used to set the vertical guides at both sides of the pile.

 direction ... Moves the vertical guide toward the pile.

 direction ... Moves the vertical guide away from the pile.

D. Back guide

This guide is used to guide the back of the paper pile.

E. F. Side guide

This guide is used to guide the side of the paper pile.

G. Side guide micro adjustment knob

This knob is used to make micro adjustments of the lateral position of the paper pile.

When turning the knob in the  direction, the side guide moves toward the operation side. The maximum movement is 5 mm (0.2") and when turning the knob one complete turn, the side guide will move 1.3 mm (0.05").

H. Paper feed table crank handle

This handle is used to raise or lower the paper feed table.

 direction ... The paper feed table will be raised.

 direction ... The paper feed table will be lowered.

I. Release lever

 position... While the machine is running, the paper feed table will be raised automatically.

 position ... Stops the paper feed table automatic elevation. To manually lower the paper feed table, set the release lever at this position and turn the crank handle.

J. Height control knob

This knob is used to set the height of the paper pile during the printing.

 direction ... The paper pile height will be raised.

 direction ... The paper pile height will be lowered.

2) Feeder

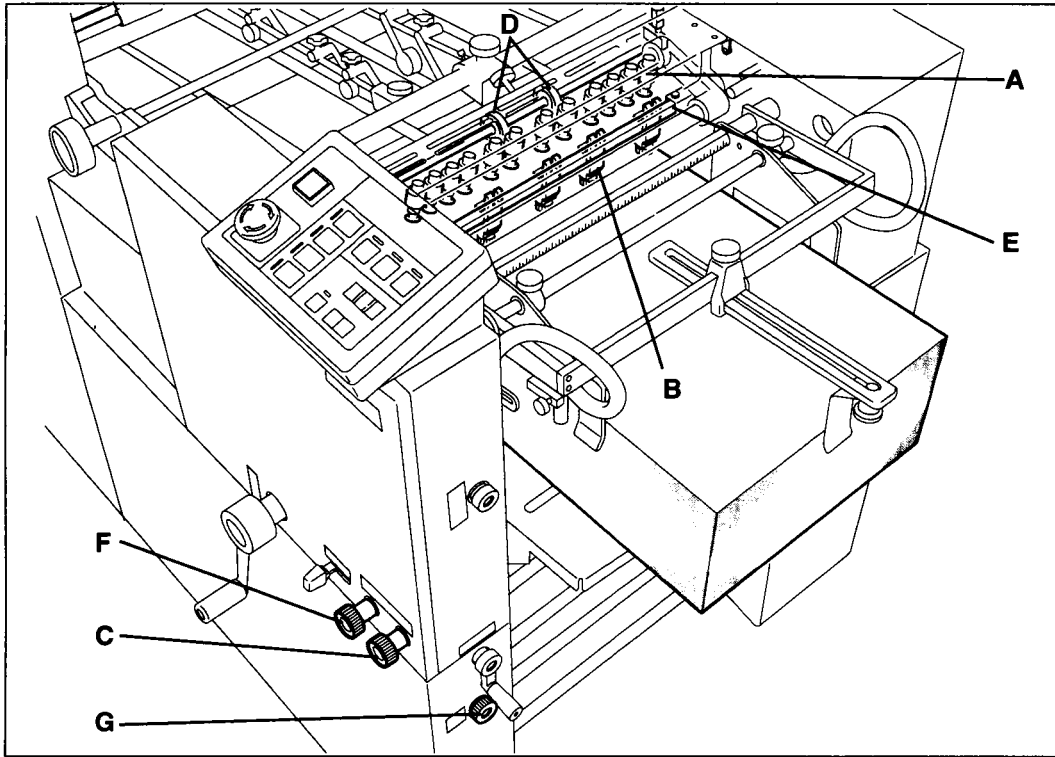

A. Suction feet

They pick up the sheet of paper and feed it to the pull-out rollers.

B. Sheet separator

This prevents double sheet feeding.

C. Vacuum control knob

This knob is for controlling the vacuum of the suction feet.

D. Pull-out roller

This roller feeds the paper sent out by the suction feet onto the feeder board.

E. Static eliminator

This is used to prevent poor paper feed caused by electrostatic that is generated on the paper during the printing.

The static eliminator will automatically go ON or OFF when the pump is ON or OFF.

F. Blower control knob

This knob is for controlling the blower volume from the blower nozzles (1) and (2).

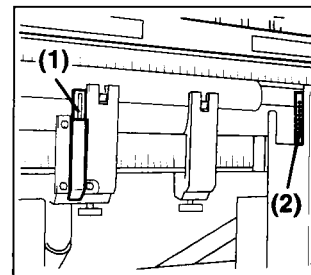

G. Auxiliary side blower control knob

This knob is for controlling the blower volume from the blower nozzle (3).

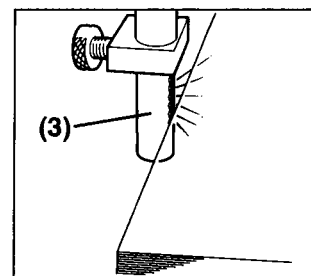

3) Double Sheet Detector, Feeder Board

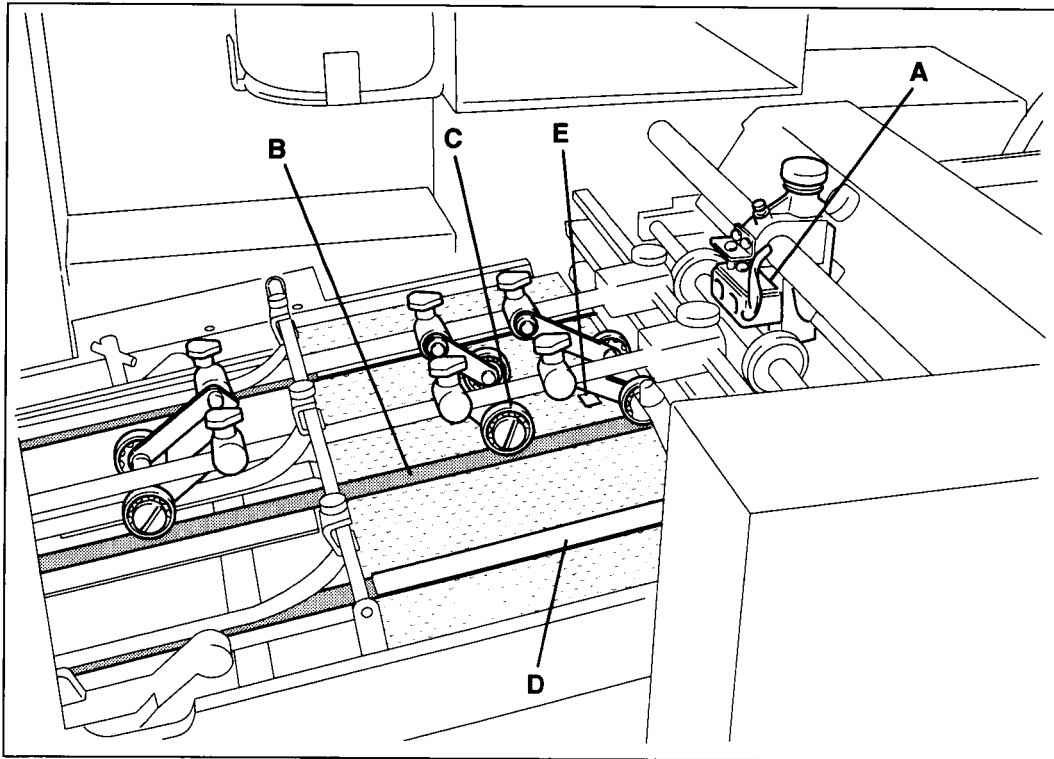

A. Mechanical type double sheet detector

When a double sheet is fed, the stop finger will rise and stop the paper on the feeder board.

B. Board tape

These carry the paper sent out by the pull-out rollers to the stop finger.

C. Skid roller

This is set on the board tape, and prevents bounce back when a sheet of paper contacts the stop finger.

D. Retainer

This keeps the paper on the feeder board flat so that it does not curl or float up from the feeder board.

E. Paper feed sensor

This detects the paper feed timing to prevent a paper feed jam from occurring and it also controls the plate cylinder and impression cylinder ON/OFF.

4) Push Side Guide, Upper Feed Roller

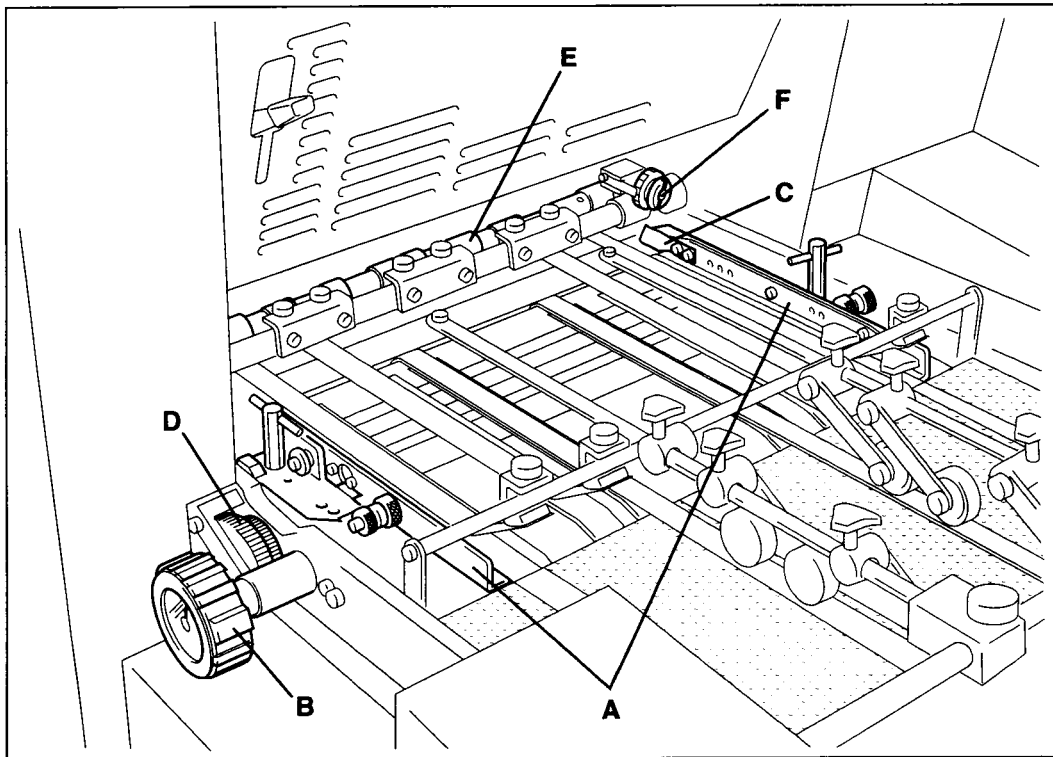

A. Push side guide

This aligns the lateral position of the paper.

B. Push side guide adjustment dial

When turning this dial, the push side guide will move laterally. Use this when adjusting the lateral position of the image on the paper.

C. Flat spring

This is used to keep the lateral registration stable by using the spring pressure to push the paper against the push side guide.

D. Flat spring micro adjustment knob

This knob is used to micro adjust the lateral position of the flat spring.

E. Upper feed roller

This feeds a sheet of the paper into the paper feed drum grippers.

F. Upper feed roller rotation volume control knob

This knob is used to control the upper feed roller rotation volume that feeds a sheet of paper to the paper feed drum.

The standard rotation volume is 1-1/4 to 1-1/2 rotations with the lower feed roller in contact.

2-8 Printing Section

1) Plate Cylinder, Blanket Cylinder, Paper Feed Drum

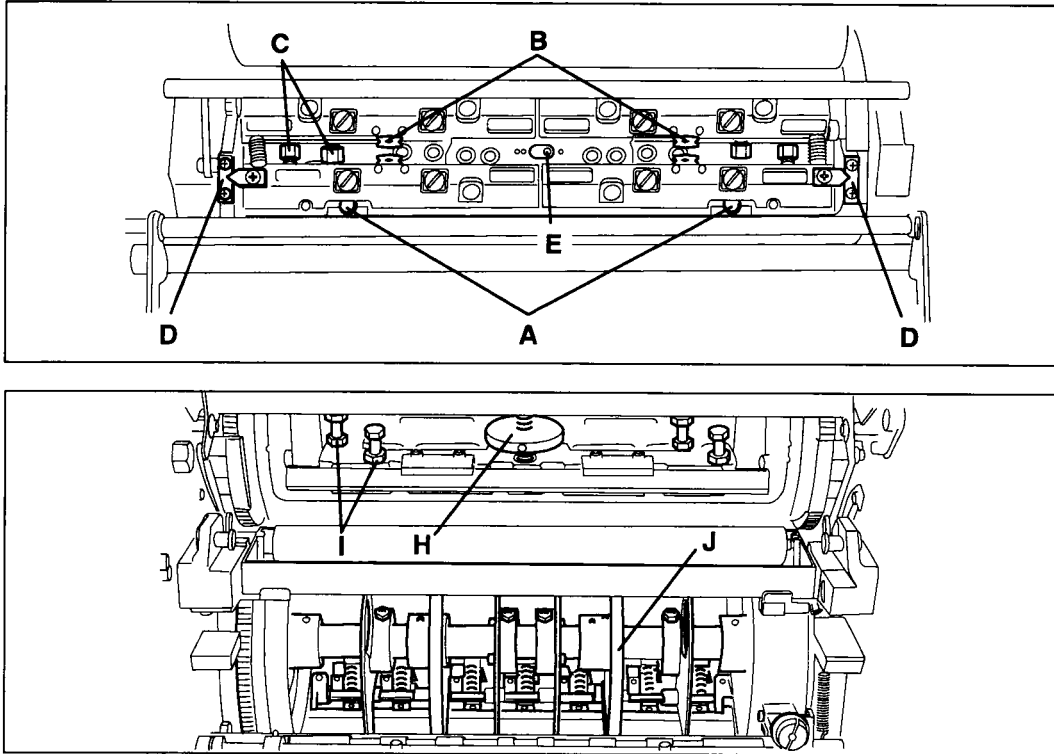

A. Plate positioning pin

The pins allow the plate to be set at the correct position.

B. Plate clamp bolt

The clamp opens and closes by turning this bolt. The yellow mark on the bolt indicates that the clamp is open and the red mark indicates that the clamp is closed.

C. Plate tensioning bolt

These bolts are used to tension the plate.

D. Plate clamp positioning scale

These scales are used when setting the clamp parallel to the cylinder, or when doing the diagonal adjustment of the plate.

E. Plate clamp tension switchover lever

This lever is used when switching the clamp tension to match the plate material used.

. . position Set at this position when using a metal plate.

. position Set at this position when using a polyester plate.

F. Quick tension bolt

This bolt is used to tension the plate.

G. Diagonal position adjustment bolt

This bolt is used to center the clamp, or to do the diagonal adjustment of the plate.

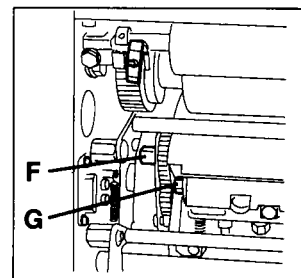

H. Tension knob

This knob is used to tension the blanket.

I. Blanket tension bolt

The blanket tension on both edges is equal by using the 2 bolts on the leading edge and tail edge.

J. Paper feed drum

This drum is the transfer drum that feeds the paper to the impression cylinder.

2) Image Micro Adjustment Device, Impression Pressure and Plate Pressure Adjustment Device

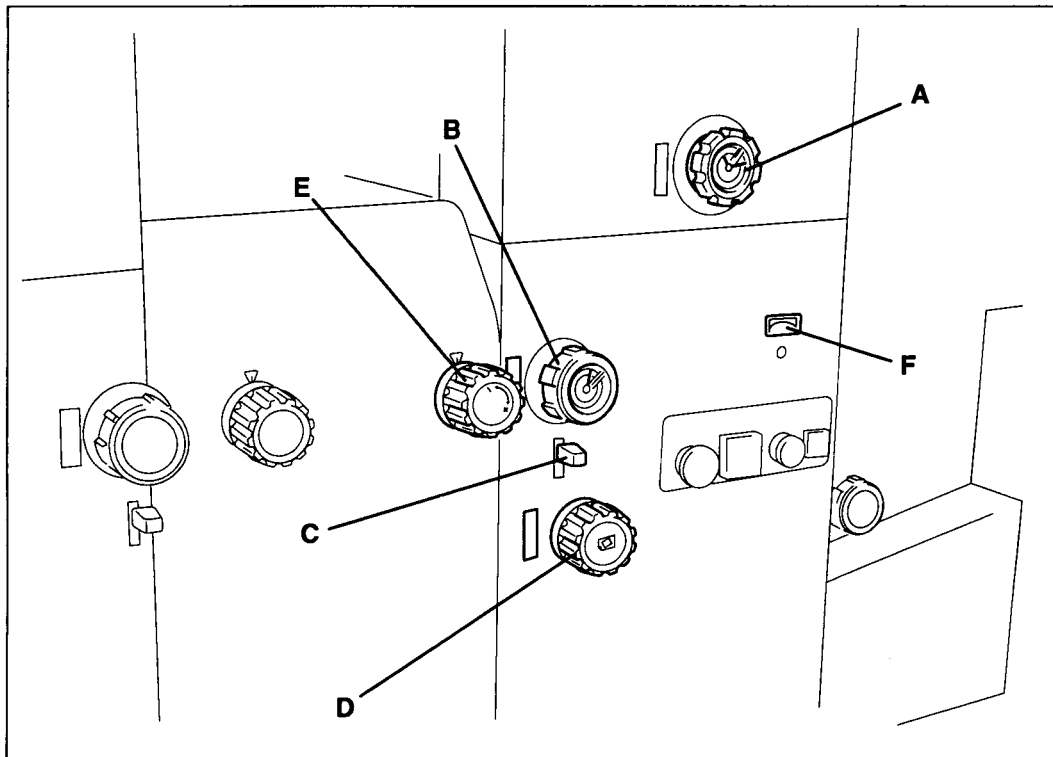

A. Plate cylinder lateral image micro adjustment dial

This dial is used when adjusting the image in the lateral direction by moving each unit plate cylinder. When turning it in the clockwise direction, the image will move toward the operation side.

B. Vertical image micro adjustment dial

This dial is used when adjusting the image on each unit in the vertical direction. When turning it in the clockwise direction, the image will move toward the leading edge side.

C. Clutch lever

When using the vertical image micro adjustment dial on each unit, push this lever down to engage the clutch.

D. Paper feed drum diagonal image micro adjustment knob

This knob is used to shift the image diagonally.

direction The non operation side image moves toward the leading edge side.

direction The non operation side image moves toward the tail edge side.

E. Impression pressure adjustment dial

Adjust the impression pressure by turning the dial on each unit. Align the dial graduation to the paper thickness printing on.

F. Plate pressure adjustment scale

This scale is used when adjusting each unit plate pressure. Turn the screw under the plate pressure adjustment scale and then align the scale graduation to the plate thickness to be used.

3) Ink Section

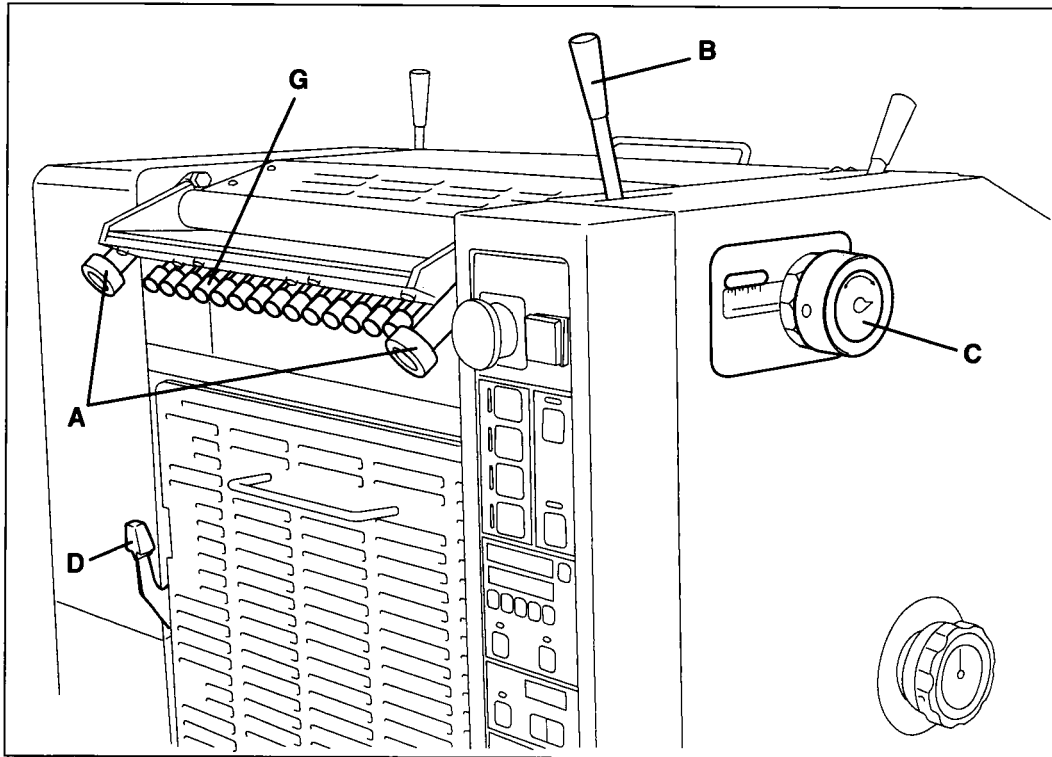

A. Ink fountain fixing knob

This knob is used to fix the ink fountain.

B. Ink fountain roller lever

This lever is used for manually rotating the ink fountain roller.

C. Ink feeding volume control dial

This dial is used to control the total ink feeding volume steplessly.

D. Ink roller cleaning lever

This lever is used when cleaning the ink rollers.

E. Ink roller cleanup attachment

The ink rollers are cleaned by using this ink roller cleanup attachment.

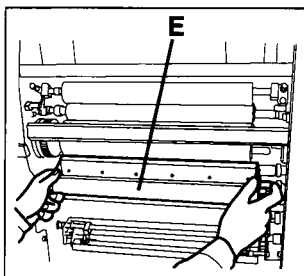

F. Ink form roller release lever

 position ... The ink form roller is always separated (OFF) from the plate surface. Set the lever at this position when the machine will not be used for a long period.

 position ... The ON/OFF of the ink form roller on the plate surface is controlled by the water and ink form roller ON button and the water and ink form roller OFF button. When printing, set the lever at this position.

(1) ... Ink first form roller and second form roller

(2) ... Ink third form roller

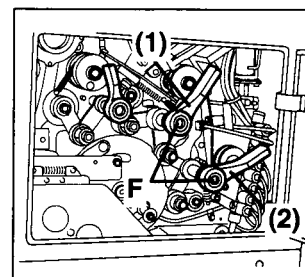

G. Ink feeding volume control screw

These screws are used to control the ink feeding volume partially based on the printed image.

4) Water Section

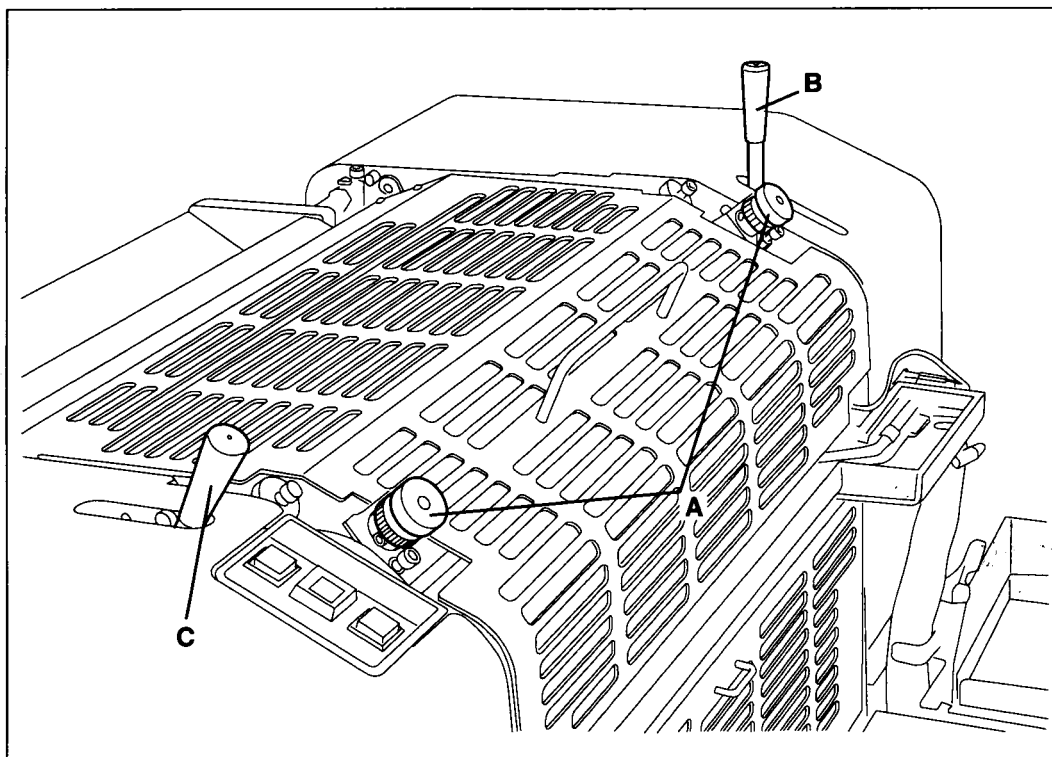

A. Metering roller pressure adjustment knob

This knob is used to adjust the pressure between the metering roller and water fountain roller.

B. Metering roller release lever

 position ... The metering roller is always separated from the water fountain roller and water oscillating roller. The squeeze roller is separated from the water fountain roller.

 position ... The metering roller contacts the water fountain roller and water oscillating roller. The squeeze roller contacts the water fountain roller. When printing, set the lever at this position.

C. Water roller cleaning lever

 position ... The bridge roller contacts the water oscillating roller. Set the lever at this position to clean the water form roller and water rider oscillating roller. (When setting the lever at this position, the water roller cleaning lever ON detector lamp lights and the printing cannot to be done.)

 position ... The bridge roller is always separated from the water oscillating roller. When printing, set the lever at this position.

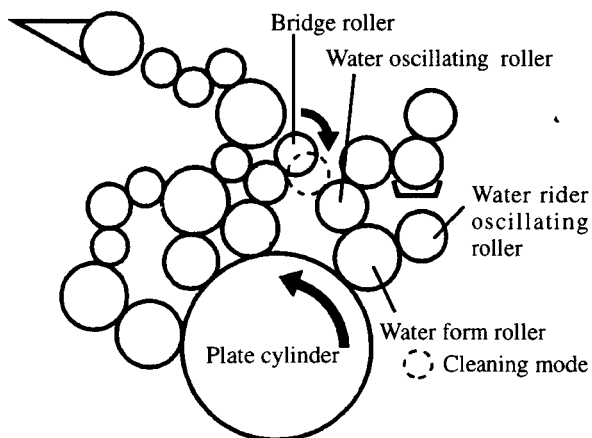

D. Water oscillating roller release knob

This knob is used to separate the water oscillating roller from the water form roller and to contact it with the water form roller. This knob is located on the operation side and non operation side.

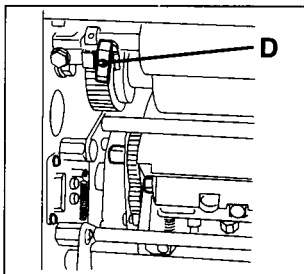

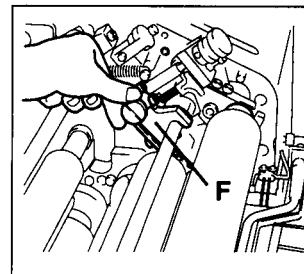

F. Water control wiper

This wiper is used to return the excess dampening solution to the water fountain to assure a stable dampening solution supply from the metering roller to the water oscillating roller.



E. Water form roller release lever

 position ... The water form roller is always separated (OFF) from the plate surface. Set the lever at this position, when the machine will not be used for a long period.

 position ... The ON/OFF of the water form roller on the plate surface is controlled by the water and ink form roller ON button and the water and ink form roller OFF button. When printing, set the lever at this position.

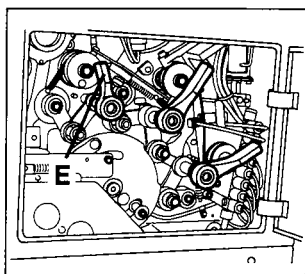

G. Dampening solution circulation device

By circulating and filtering the dampening solution, it keeps the condition of the dampening solution stable.

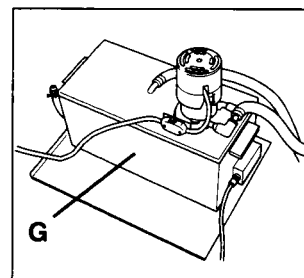

2-9 Delivery Section

1) Delivery Guides

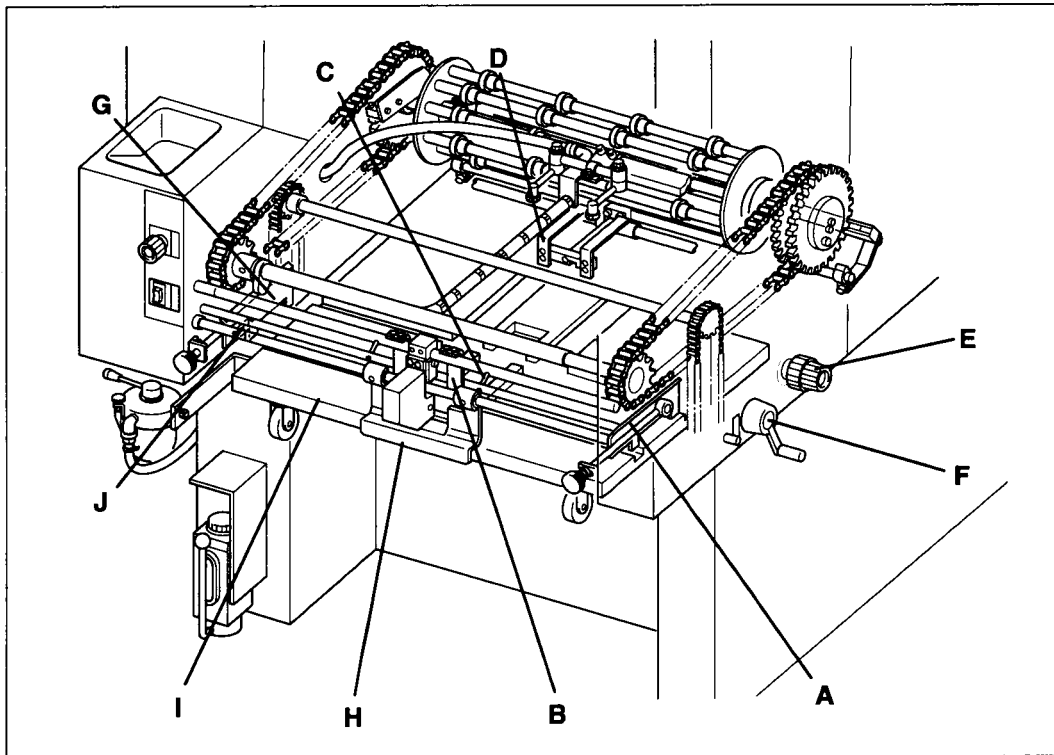

A. Side jogger

This guide jogs to even up the side of the printed sheets delivered onto the delivery table dolly.

B. Paper drop

This drops the printed sheet of paper onto the delivery pile after it is released by the delivery grippers.

C. Delivery jam detector

When a delivery jam occurs, it will stop the machine. After removing the paper, the machine can be run again.

D. Back guide

This is the jogger guide that is used to align the vertical position of the sheets delivered.

E. Back guide set knob

This knob is used to set the back guide position.

F. Delivery table dolly crank handle

This handle is used to raise or lower the delivery table dolly.

G. Side guide

This is the fixed guide that is used to set the lateral position of the sheets delivered.

H. Front guide

This is the fixed guide that is used to align the leading edge of the sheets delivered.

I. Delivery table dolly

The delivered sheets of paper are piled on this dolly.

J. Delivery pile lowering sensor

This sensor detects the height of the delivered sheets. When the pile reaches the specified height, the delivery table dolly is lowered automatically.

K. Delivery table dolly lower limit switch

When the delivery table dolly is fully lowered, this switch will actuate and the paper feed will stop automatically.

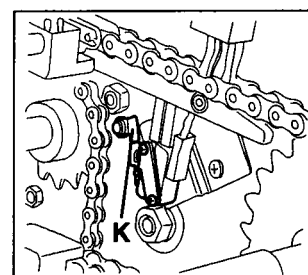

2) Rotary Guide, Delivery Air Blower

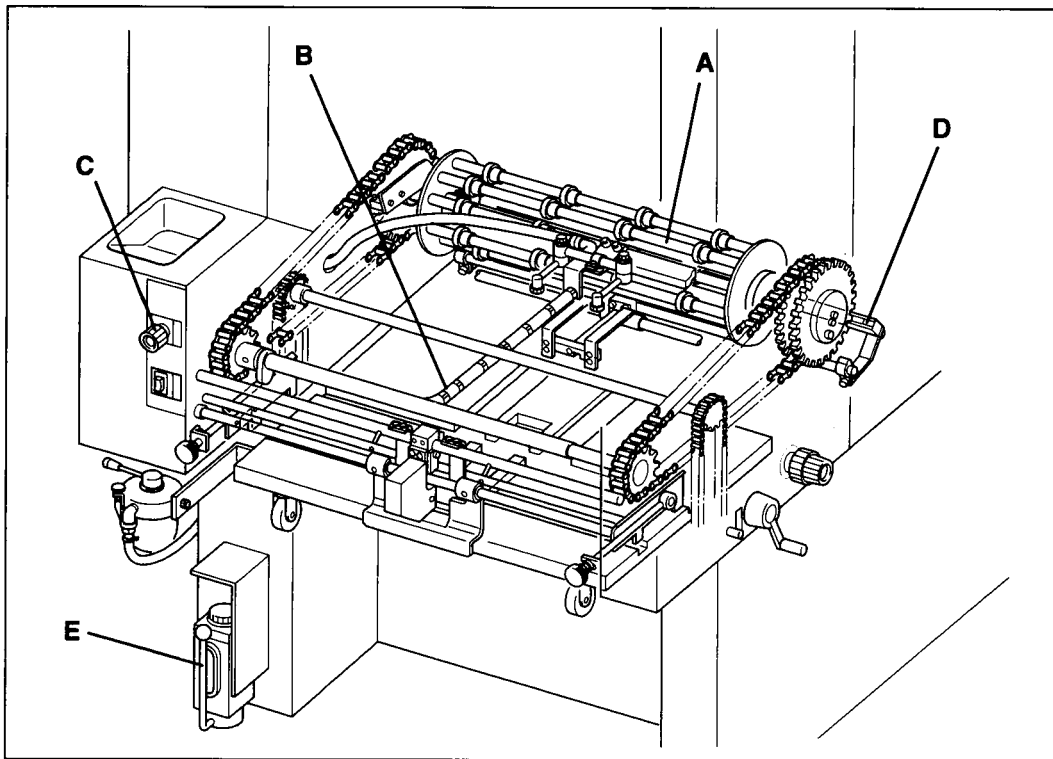

A. Rotary guide

This guide holds the printed sheet of paper transferred from the impression cylinder gripper to the chain delivery gripper.

B. Delivery air blower

The force of the air from the air blower drops the sheet of paper that is released by the delivery grippers onto the pile.

C. Delivery air blower control knob

This knob is used to control the delivery air blower output volume. When turning it in the clockwise direction, the blower force will be increased.

D. Static eliminator

This is used to prevent poor delivery caused by electrostatic that is generated on the paper during the printing.

The static eliminator will automatically go ON or OFF when the pump button is ON or OFF.

E. Centralized oiling system

Pull the centralized oiling pump lever and release it after 2 to 3 seconds and the oil will be supplied.

Pull the lever 2 to 3 times before running the machine.

3) Powder Spray Device

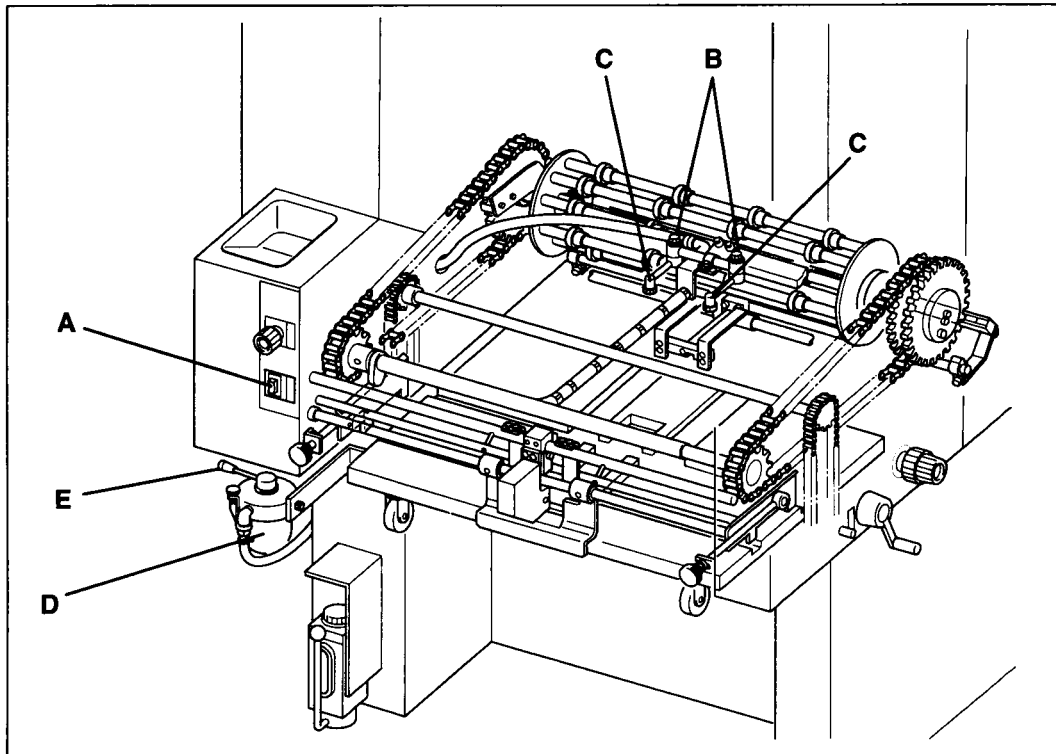

A. Spray switch

This is the powder spray device power switch.

(Automatic)... The device will operate during the paper feeding.

When printing while using the device, usually set the switch at this position.

(OFF) The device will not operate.

(ON) The device will operate continuously and spray the powder even when the paper does not pass.

B. Spray volume control plate

This plate is used to control the spray volume outputted from each nozzle.

The center position of the scale is the maximum spray volume.

To prevent possible trouble, control the spray volume to keep it at the minimum necessary.

C. Spray nozzle

The spray powder is sprayed from this nozzle on to the printed sheet of paper.

This can be moved up to 90° to match the printing paper size and image.

D. Powder bottle

This is the bottle to put the spray powder in.

E. Spray volume control lever

This lever is used to control the total spray volume outputted from the powder bottle.

Operation Edition

This edition is composed of Chapter 1 “Operation Procedures” and Chapter 2 “Printing Practice” and explains the basic printing procedures and points.



Operation Procedures

The basic printing procedures when using a punched plate and printing on paper with a size of 310 x 440 mm (12.20 x 17.32") and a thickness of 0.1 mm (0.004") will be explained.

1. Plate Making

If the image position is incorrect, more time and work will be required for the vertical and diagonal image adjustment before printing. Reproduce the image accurately to assure efficient registration operation.

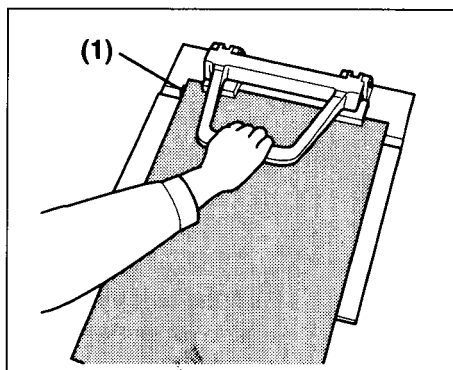
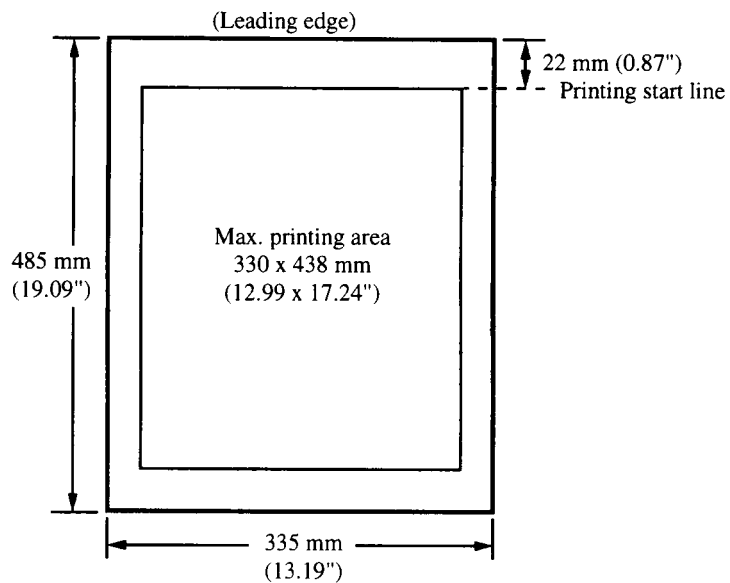

Before doing the punch processing, first match the graduation of the RP22 register punch scale (1) with the plate width. Then set the plate on the RP22 and punch the holes.

(Reference) For higher efficiency and more accurate punch processing, we recommend using the RP520-220F register punch.

2. Water Section Preparation

1) Prepare the dampening solution circulation device.

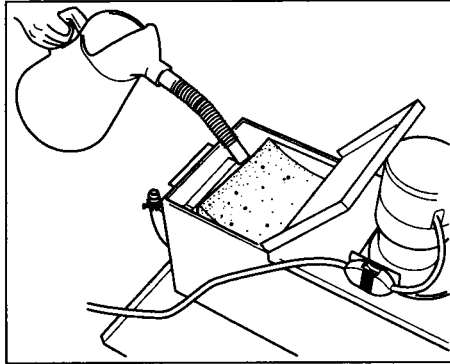

Make the dampening solution in which the alcohol substitute with the proper density is added in advance. Then pour it up to the line in the tank. For the proper density of the alcohol substitute, refer to the explanation of the alcohol substitute used. (Reference) The tank capacity is 13.4 liters of dampening solution.

When the dampening solution in the tank falls below the minimum level, the buzzer will sound to inform the operator.

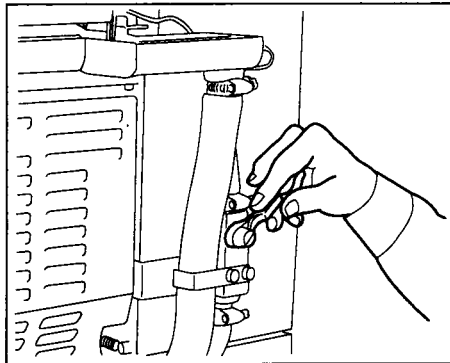

Check that the water fountain dampening solution level is high enough to soak the water fountain roller. If not having enough dampening solution, increase by using the water volume control valve. When turning it in the counterclockwise direction, the volume will be increased.

2) Set the metering roller.

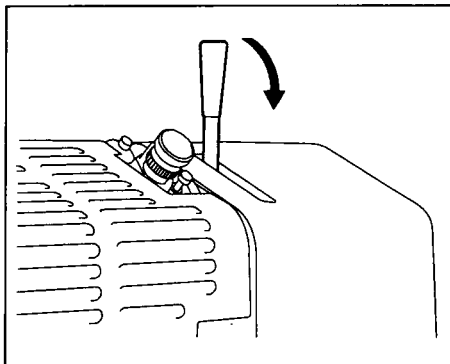

Shift the metering roller release lever in the direction of the arrow ( position) and contact the metering roller with the water fountain roller.

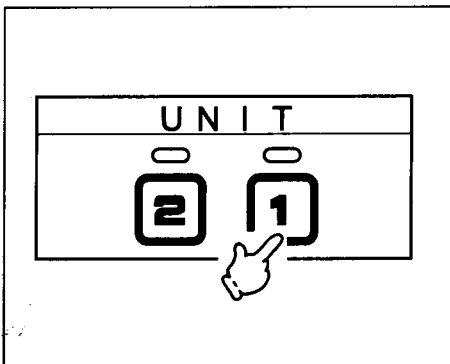

Push the unit selection button for the unit to be used to rotate the water fountain roller.

(Note) If there is no dampening solution in the water fountain, the water sensor in the water fountain will stop rotating the metering roller. The paper feed also cannot be done.

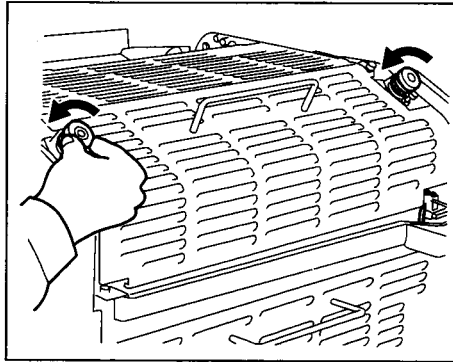

Turn the metering roller pressure adjustment knob and adjust the aqua film thickness on the metering roller.

Turn the metering roller pressure adjustment knob in the “+” direction (in counterclockwise direction) 10 pitches more from the position that the aqua film is just cut on the metering roller.

3) Set the water rider oscillating roller.



CAUTION

Stop the machine before setting. Failure to follow this instruction may result in an injury.

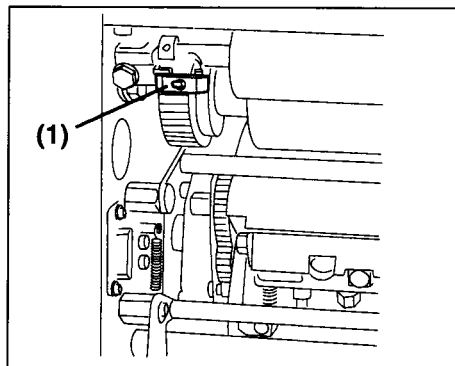

Turn the water rider oscillating roller release knob (1) and set at the 12 o'clock position.

When there is a unit which is not used, be sure to turn the knob (1) and set at the 3 o'clock position and pull the water rider oscillating roller by hand toward you so that the water rider oscillating roller is released from the water form roller.

3. Mounting the Plate (Metal Plate)

1) Mount the plate (metal plate).

Mounting procedures

■ Plate cylinder pre-determined position stop function

When pushing the forward crawl button on each crawl operation panel with the drive lamp lighted, the cylinders will rotate and stop automatically at the position where it is easy to mount the plate. (P. 50)

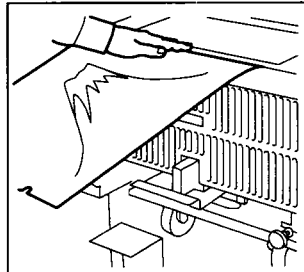

1. Bend the plate tail edge.

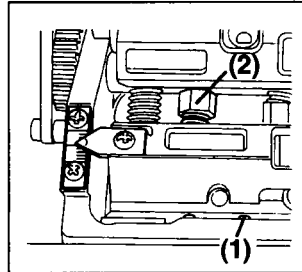

2. Return the leading edge of the plate clamp to the standard position (vertical direction). Loosen the plate tensioning bolt (2) until the stopper (1) contacts the plate cylinder. (Operation and non operation sides)

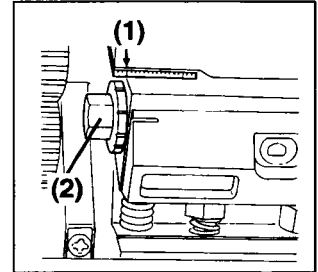

3. Return the tail edge of the plate clamp to the standard position (lateral position). Turn the bolt (2) so that the edge of the plate clamp is aligned with the third line (1) from the left edge of the scale on the plate cylinder.

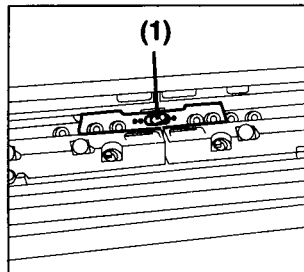

4. Set the plate clamp tension switchover lever (1) at the position.

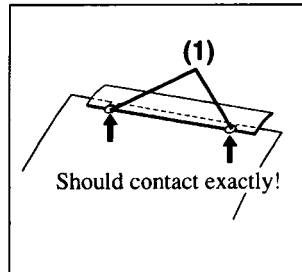

5. Insert and contact the plate onto the positioning pins (1) of the plate clamp on the leading edge.

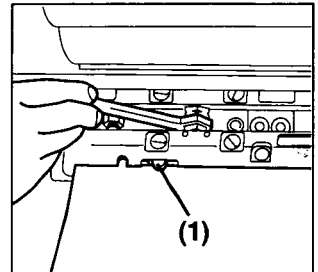

6. Turn the clamp bolt until the red mark faces you to fix the plate leading edge. Check that the plate contacts the positioning pins (1) exactly.

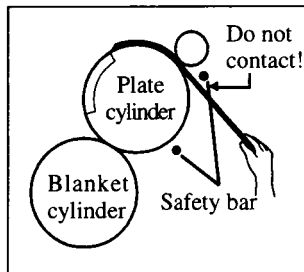

7. Mount the plate on the plate cylinder. At this time, be careful not to contact the plate on the safety bar. If the plate contacts the safety bar, the plate may be scratched.

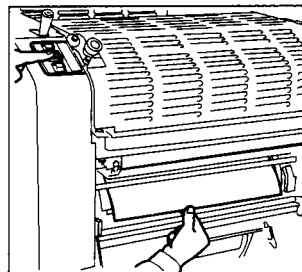

8. Before fixing the tail edge of the plate, push the plate hold-down button and contact the water form roller on the plate surface.

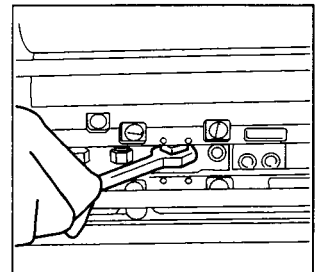

9. Insert the tail edge of the plate into the clamp and turn the clamp bolt until the red mark faces you to fix it.

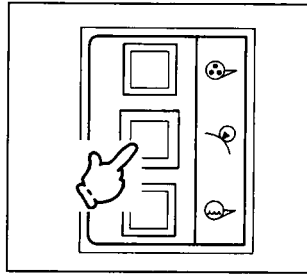

10. Push the plate hold-down button to release the water form roller from the plate surface.

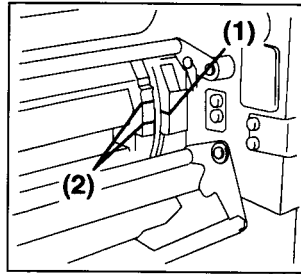

11. Push the crawl button so that the line (1) on the plate cylinder gear cover is between the 2 lines (2) on the plate cylinder.

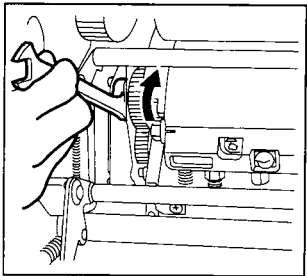

12. Turn the quick tension bolt in the direction of the arrow to tension the plate.



CAUTION

Remove the wrench from the quick tension bolt before pushing the crawl button, when the plate cannot be tensioned properly at the plate cylinder gap position. Failure to follow this instruction may result in an injury.

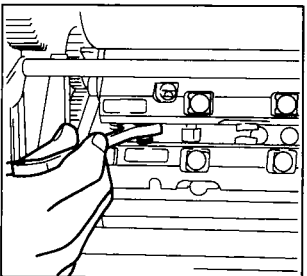

13. When having the insufficient plate tension, tension the plate by using the plate tensioning bolts. The plate tensioning bolts on both the operation side and non operation side should be turned 2 to 3 times alternately.

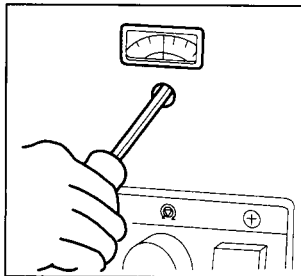

(Reference)

Align the thickness of the plate being used to the same thickness graduation on the plate pressure adjustment scale.

4. Setting the Paper Feed Section

1) Pile the paper on the paper feed table.



CAUTION

Stop the machine before piling. Failure to follow this instruction may result in an injury.

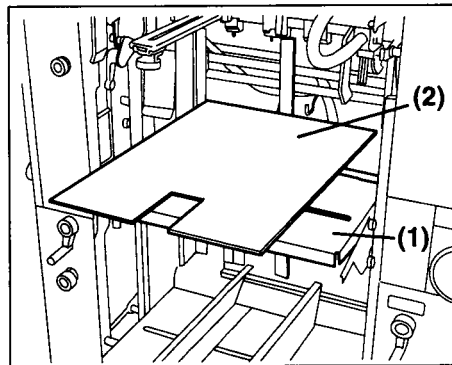

Put the paper pile board (2) on the paper pile board support (1).

(Reference) There are 4 different size paper pile boards included with the machine. Use the board that corresponds to the sheets of paper to be printed.

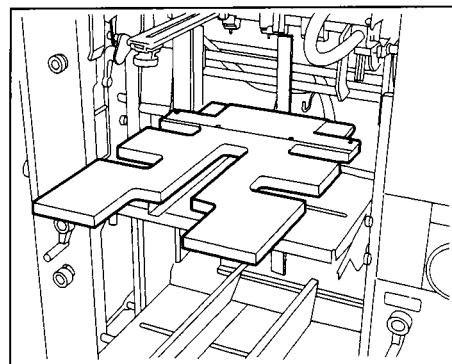
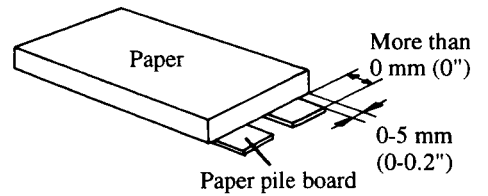

A multi-size paper pile board that can hold paper from 170 x 210 mm (6.69 x 8.27") to 340 x 450 mm (13.39 x 17.72") in size is available as an optional accessory.

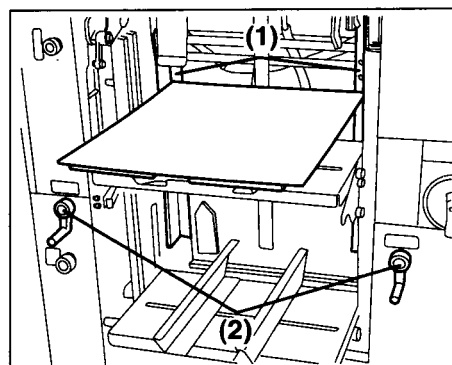

Pile a few sheets of paper on the paper pile board, then set the vertical guides (1) on both edges of the paper. The vertical guide is moved by turning the handle (2). Position the vertical guide using the scale on the stay. Adjust the paper lateral position so that the operation side and non operation side will be on the same graduation on the scale.

Pile the paper.

2) Set the sheet separator position.



CAUTION

Stop the machine before setting. Failure to follow this instruction may result in an injury.

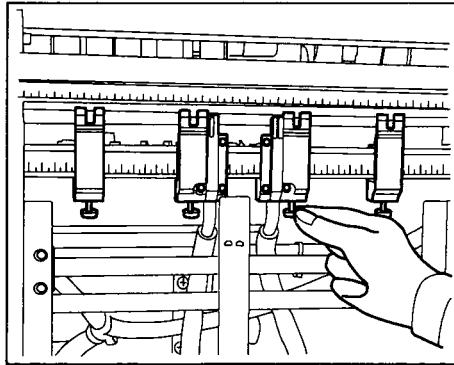

Loosen the screw and move the sheet separator to the proper position.

(Note) Normally 4 sheet separators are used. The sheet separators on both edges should be located a little inward from the suction feet on each outer side to be used.

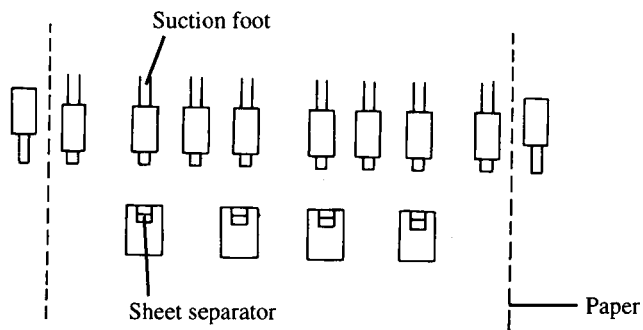

3) Adjust the paper pile height.



CAUTION

Do not put your hand on the feeder pile while it is rising. Failure to follow this instruction may result in an injury.

Setting procedures

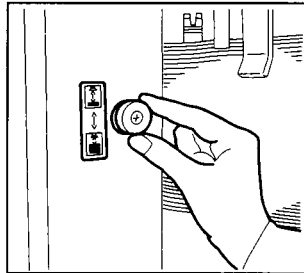

1. Turn the height control knob 3 to 4 turns in the clockwise direction.

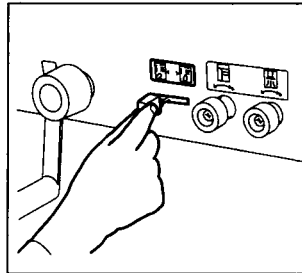

2. Run the machine and set the release lever at the  position to raise the paper feed table automatically.

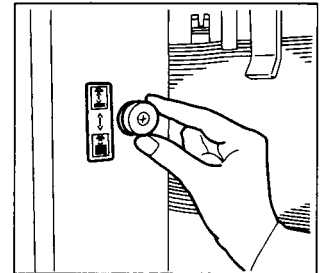

3. Adjust the paper pile height by turning the height control knob slowly in the counter-clockwise direction.

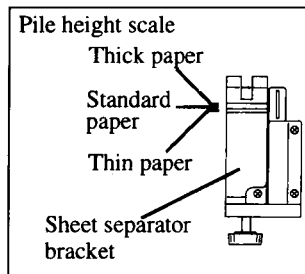

4. The top sheet of paper is aligned with the pile height scale.

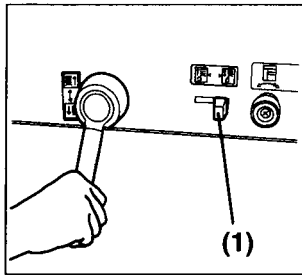

(Note) When the paper pile position is too high, set the release lever (1) at the  position and turn the crank handle to lower the paper feed table, then repeat the steps 1 to 3.

4) Set the guide position.



CAUTION

Stop the machine before setting. Failure to follow this instruction may result in an injury.

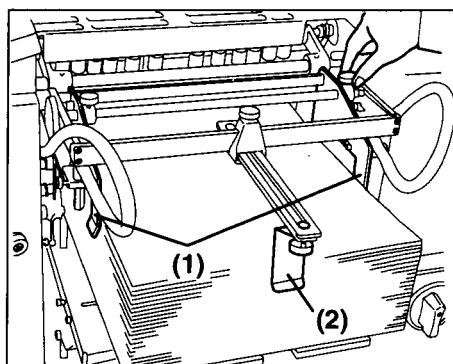

Set the side guides (1) (on both the operation and non operation sides) and back guide (2) to contact the paper edges.

And, set the back guide (2) so that it is located in the notched section of the paper pile board.

5) Set the suction feet.



CAUTION

Stop the machine before setting. Failure to follow this instruction may result in an injury.

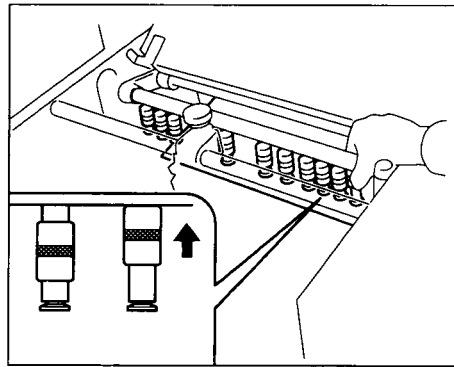

Stop the vacuum to the suction feet which are only partially on or completely off the paper. When raising it fully, the vacuum will stop.

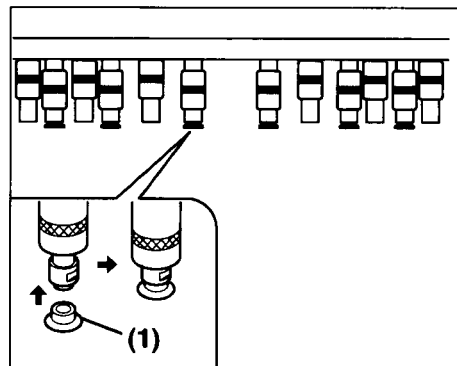
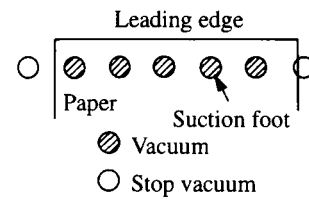

<Setting the thick paper>

When printing on thick paper, mount the rubber suckers (1) on every other suction foot.

At this time, the vacuum of the suction feet that the rubber suckers are not mounted should be stopped.

(Note) 1. When using the rubber suckers, turn the vacuum control knob to 1/2-1 turn back in the counterclockwise direction from the maximum position.

2. When the rubber sucker wears out, the suction foot vacuum force will decrease causing paper feed problems. If this occurs, replace the rubber sucker with a new one.

6) Control the vacuum volume and blower volume.

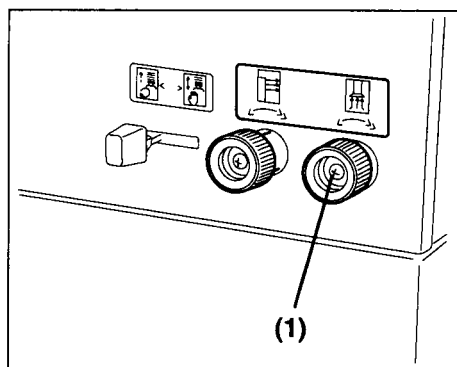

Control the vacuum volume.

When printing on paper with a thickness of over 0.1 mm (0.004"), set the vacuum control knob (1) to the maximum (fully turned clockwise) position. For the paper with a thickness less than 0.1 mm (0.004"), turn the knob to 1/2-1 turn back in the counterclockwise direction from the maximum position.

■ When controlling the blower volume

Pump button ON

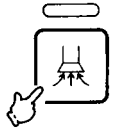

Drive button ON

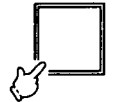

Set speed drive button ON

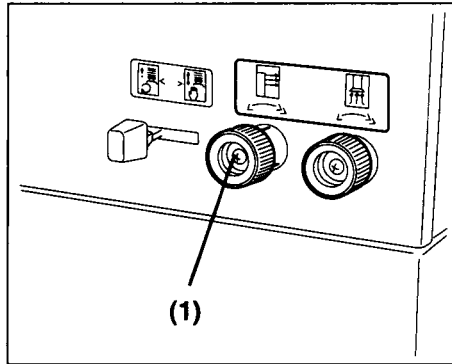

Control the blower volume of the center blower and side blower.

Turn the blower volume control knob (1) so that the top sheet of paper contacts the sheet separator lightly.

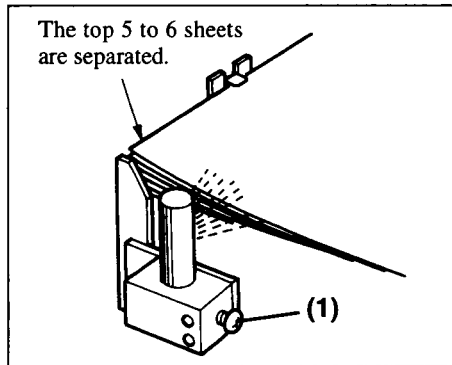
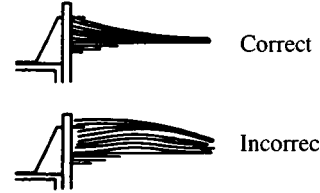

Loosen the screw (1) and adjust the height of the side blowers so that the top 5 to 6 sheets of paper are separated.

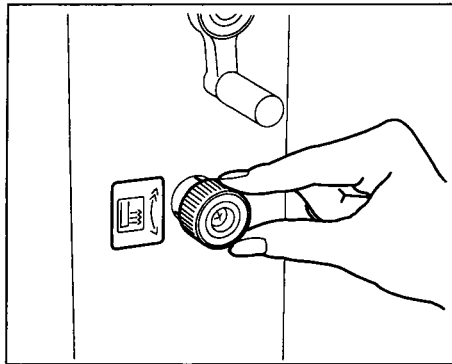

Control the auxiliary side blower volume.
(Reference) When printing with coated paper, if the paper separation is poor, use the auxiliary side blower to completely separate the sheets of paper. When turning the auxiliary side blower control knob in the clockwise direction, the blower volume is increased.

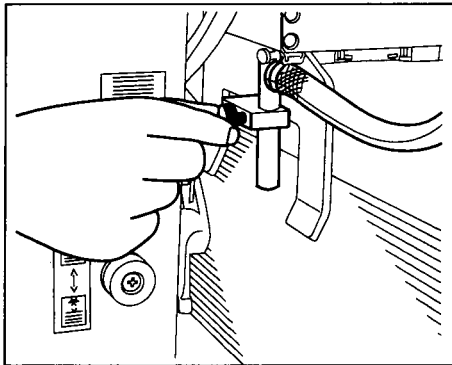

Loosen the screw and adjust the height of the blower nozzle so that it separates the top 10 to 15 sheets of paper.

7) Set the mechanical type double sheet detector.



CAUTION

Stop the machine before setting. Failure to follow this instruction may result in an injury.

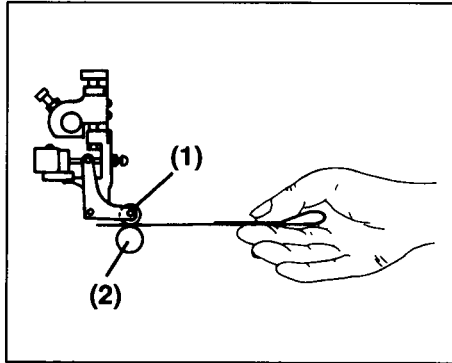

Cut a strip of paper from a sheet of paper to be used for printing, and fold it in half as shown in the illustration. Insert it between the detector roller (1) of the double sheet detector and feed roller (2).

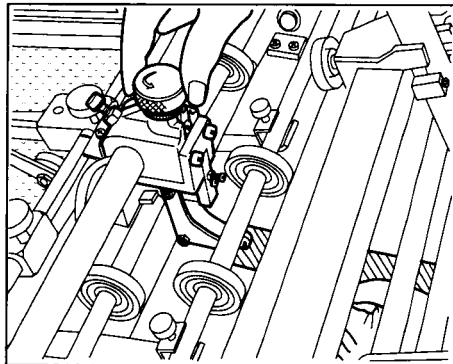

When the double sheet detector actuates, the buzzer will sound.

Turn the adjustment knob to adjust the double sheet detector so that the detector actuates when a double sheet of paper is fed, but does not actuate when only one sheet of paper is fed. When turning the adjustment knob in the direction of the arrow, the clearance between the detector roller and feed roller will be reduced for thin paper.

8) Set the pull-out rollers position.



CAUTION

Stop the machine before setting. Failure to follow this instruction may result in an injury.

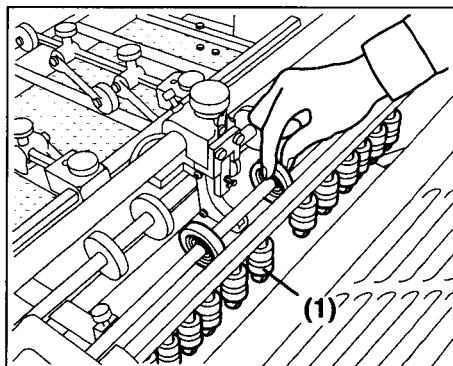

Adjust the position of the pull-out rollers.

The pull-out rollers are set so as not to contact the suction foot (1) and be at equal distance from the center of the paper.

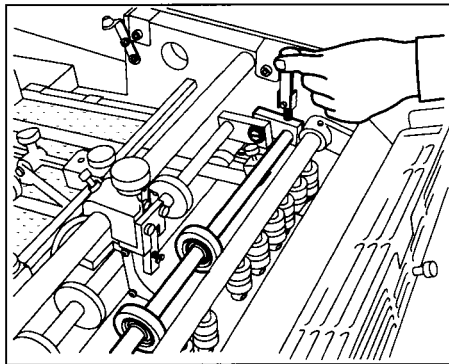

Adjust the pull-out roller pressure. While rotating the pull-out roller with your finger lightly, adjust the pressure by turning the adjustment knob so it is the same on both the operation and non operation sides. When turning the adjustment knob in the counterclockwise direction, the pressure is increased.

9) Set the guide rollers position.



CAUTION

Stop the machine before setting. Failure to follow this instruction may result in an injury.

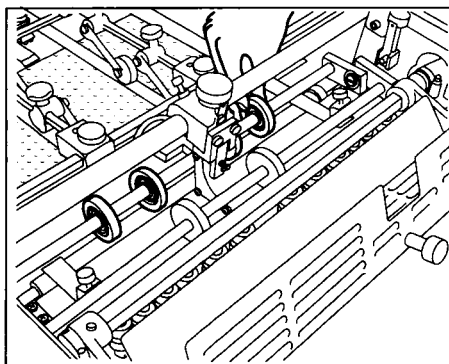

Normally set 4 guide rollers at the position where they do not contact the retainers.

5. Setting the Registration Section

1) Set the push side guide.



CAUTION

Stop the machine before setting. Failure to follow this instruction may result in an injury.

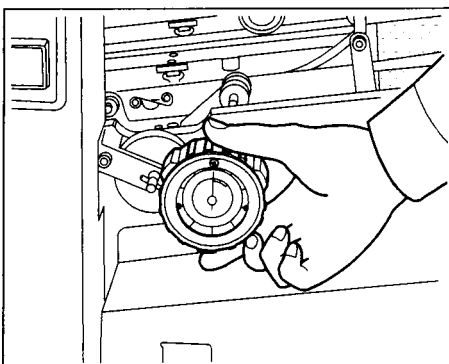

Set the indicator on the push side guide adjustment dial in the center (2 on the scale).

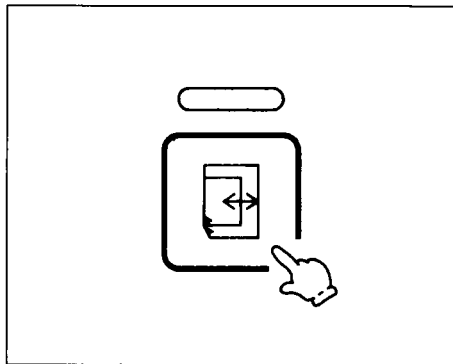

Run the machine and push the paper size change button to feed the paper to the stop finger.
 (Reference) After the paper arrives at the stop finger, the machine stops automatically.

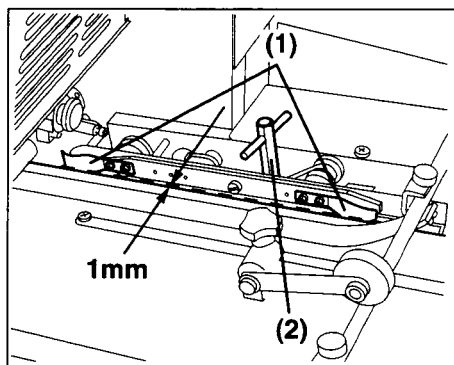

Loosen the fixing screw (2) of the flat spring (1), and position the flat spring so that it is about 1 mm (0.039") from the edge of the paper and fix it.
 (Reference) On the flat spring plate (3), there is a scale with 1 mm (0.039") interval markings. Use this to set the standard position of the flat spring.

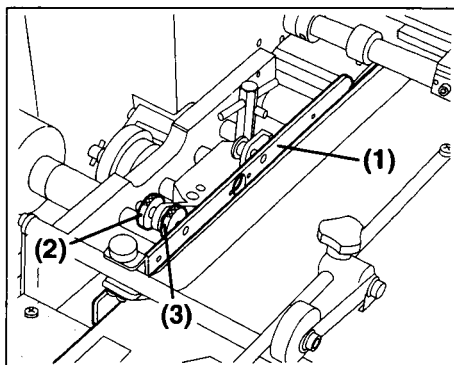
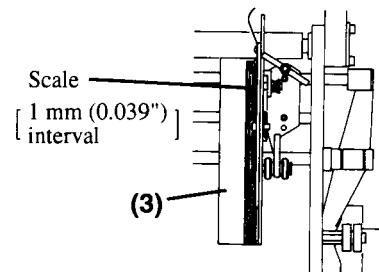

Push the forward crawl button and stop the jogger guide (1) at its fully pushed position.
 If the jogger guide does not contact the paper edge in parallel, loosen the lock nut (2) and adjust the jogger guide by using the adjustment screw (3).

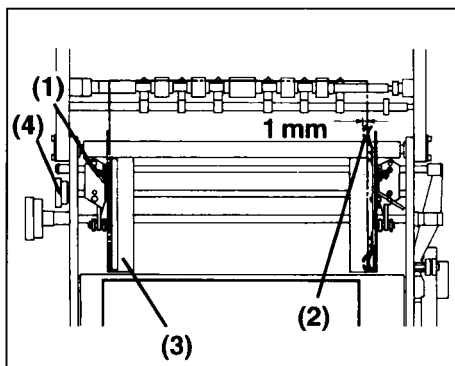

Loosen the fixing screw (1) and adjust the jogger guide (3) position so that the flat spring (2) is bent about 1 mm (0.039").
 Adjust the flat spring bending volume by using the micro adjustment knob (4).

<< NOTICE >>

If the fixing screw is tightened by using the wrench or other tool, the bracket may be damaged. Only tighten the fixing screw by hand.

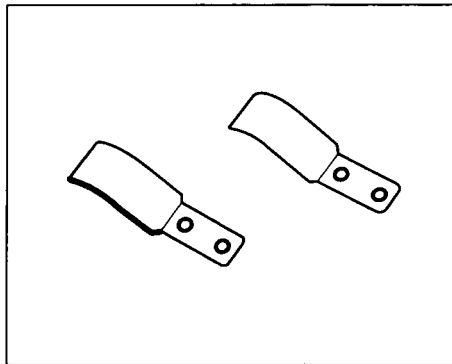

(Reference) There are 2 types of flat spring, one for thin paper and the other for thick paper. The thin flat spring is used for paper with a thickness of less than 0.1 mm (0.004").

(Reference) Switching over the push side guide from the operation side to the non operation side can be done.

Switching over procedures

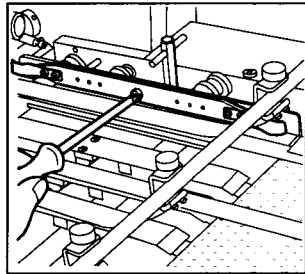

1. Loosen the fixing screw and remove the non operation side flat spring and mount it on the operation side.

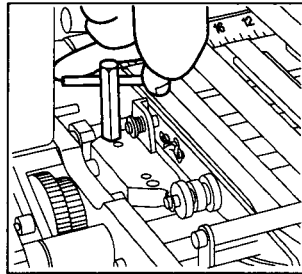

2. Remove the push side guide fixing screw on the operation side.

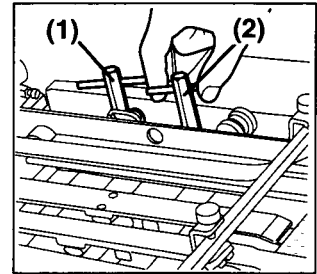

3. Mount the screw (1) in the non operation side push side guide and fix it and then loosen the screw (2).

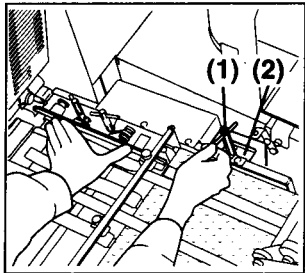

4. Loosen the screw (1) and move the push side guide cam (2) in the condition where the non operation side push side guide is pushed toward the frame side.

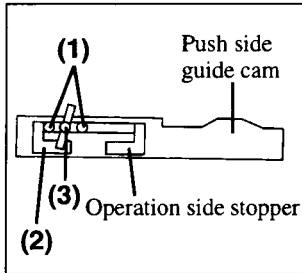

At this time, connect the pin (1) on the non operation side stopper (2) exactly. Finally fix the fixing screw (3).

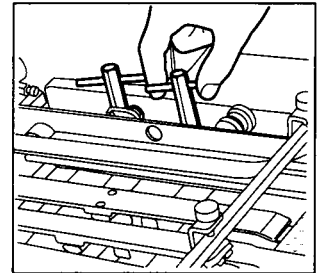

5. Remove the fixing screw.

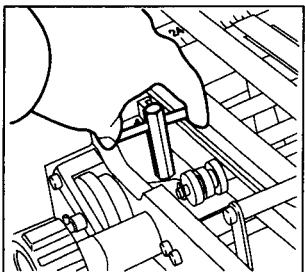

6. Mount the fixing screw on the operation side push side guide.

<< NOTICE >>

If the fixing screw is tightened by using the wrench or other tool, the bracket may be damaged. Only tighten the fixing screw by hand.

2) Position the board tapes.



CAUTION

Stop the machine before setting. Failure to follow this instruction may result in an injury.

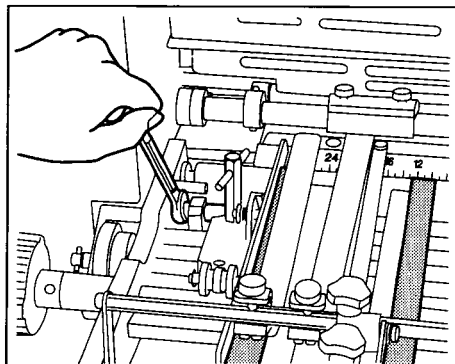

The board tape can be moved by turning the board tape tensioner shaft.

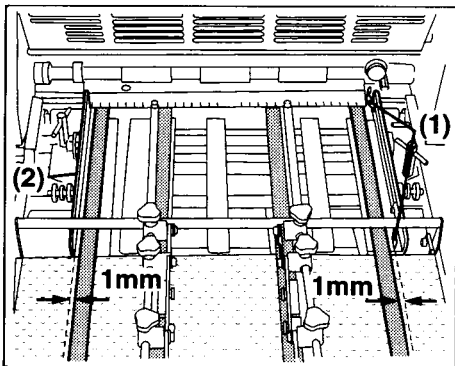

Set the jogger guide at the position where it is fully pushed.

Set both edge board tapes where they are 1 mm (0.039") away from the flat spring (1) and jogger guide (2).

The other board tapes should be positioned to have even space between them.

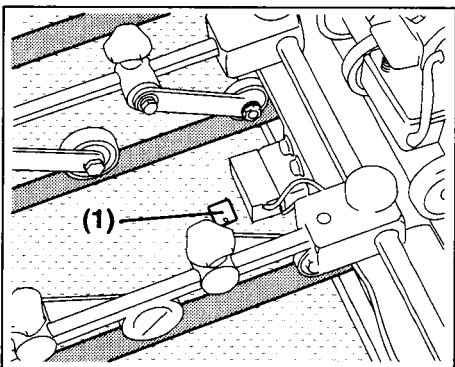

(Note) Please be careful not to cover the paper feed sensor (1) with the board tape.

3) Set the retainers.



CAUTION

Stop the machine before setting. Failure to follow this instruction may result in an injury.

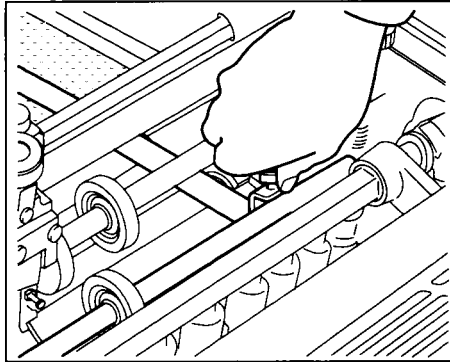

There are 2 different retainers. The retainer (A) has a square edge. The retainer (B) has a rounded edge. Mount the retainer (A) on the pull-out roller shaft.

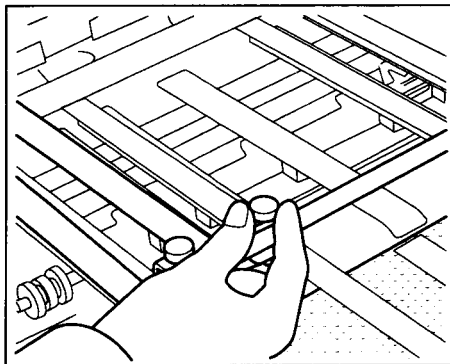
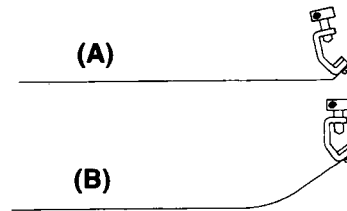

Mount the retainer (B) on the shaft over the feeder board. There are 2 types of retainers, one for thin paper and the other for thick paper. When using paper less than 0.1 mm (0.004") thick, use the thin retainer.

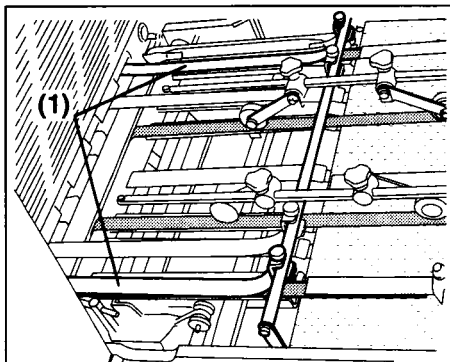

The retainers (1) should always be set on both outer board tapes.

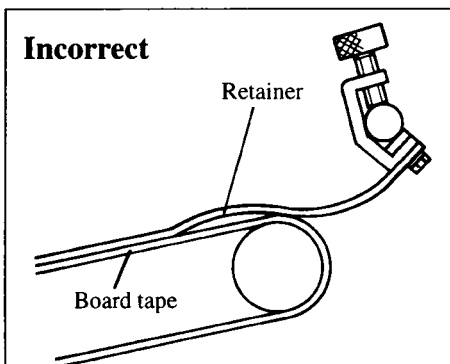

(Note) Do not push the retainer down strongly.

4) Set the skid rollers.

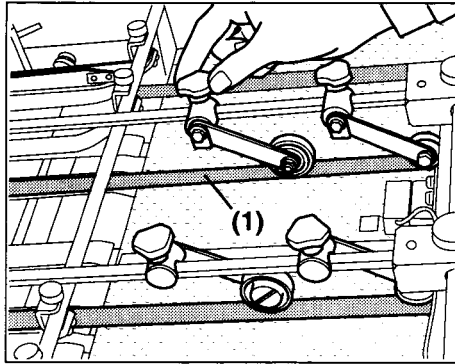

Set the skid rollers on the board tapes (1) that do not have retainers mounted.

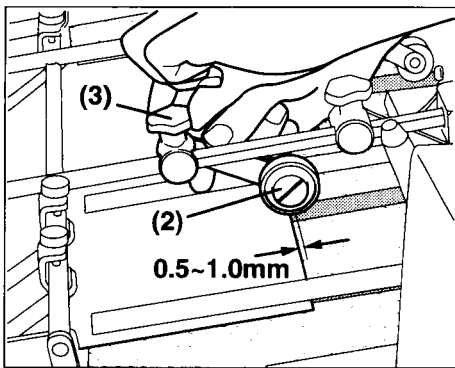

Adjust the position of the skid rollers. With the paper contacted with the stop finger (1), loosen the screw (3) and adjust the skid roller position so that the center of the skid roller (2) is located 0.5-1 mm (0.020-0.039") behind the tail edge of the paper.

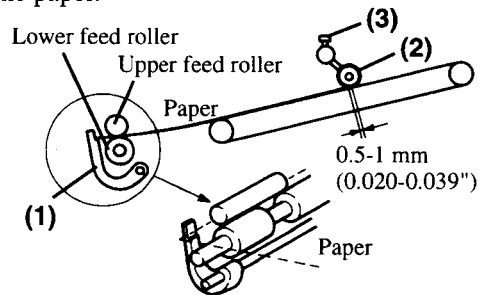

6. Setting the Delivery Section



WARNING

Stop the machine before setting. Failure to follow this instruction may result in a serious injury.

1) Set the delivery table dolly.

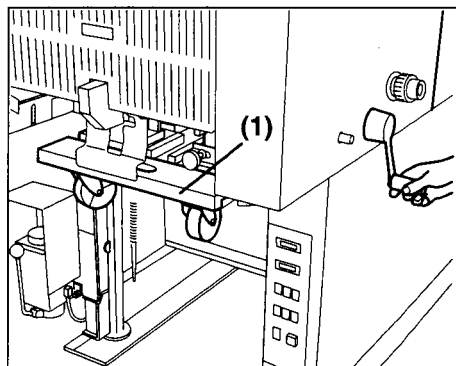

Elevate the delivery table dolly (1) by turning the crank handle.

■ When feeding the paper on the feeder board to the delivery section.

Drive button ON

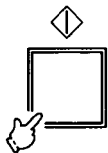

Paper size change button ON



2) Set the side guide position.

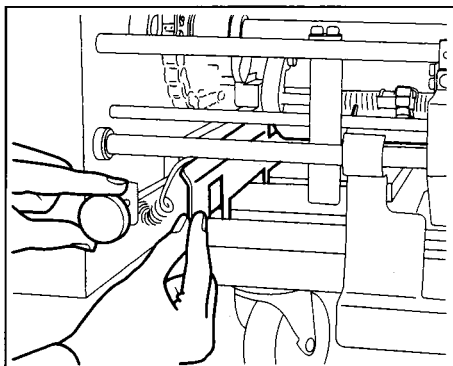

Feed a sheet of paper up to the delivery section. Then loosen the knob and set the delivery side guide at the position 3 mm (0.12") away from the side of the sheet of paper.

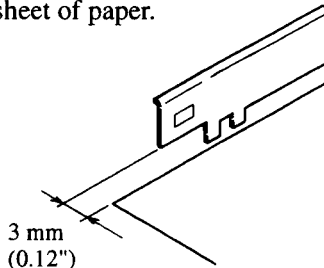

3) Set the side jogger and back guide position.

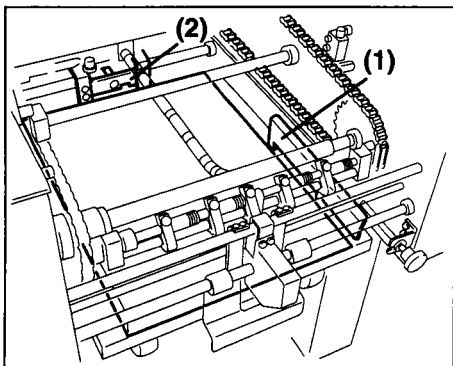

Push the forward crawl button and drop a sheet of paper on the delivery table dolly. Stop where the side jogger (1) and back guide (2) are the closest to the paper.

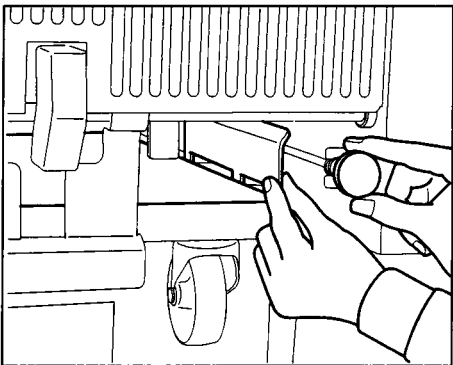

Loosen the knob and contact the side jogger on the paper lightly.

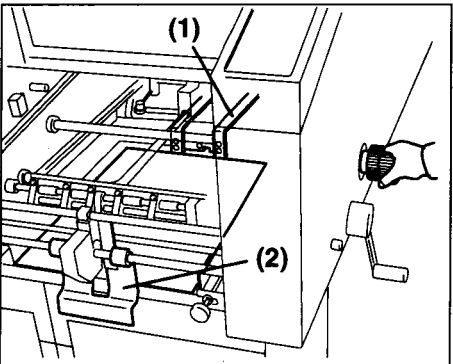

Turn the back guide set knob and contact the back guide (1) and front guide (2) on the paper lightly.

7. Test Feeding

Feeding the sheets of paper, check and adjust each section.

■ Test feeding procedures

Drive button ON

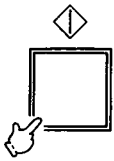

Pump button ON

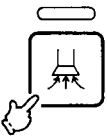

Paper feed button ON



Paper feed button OFF



Pump button OFF

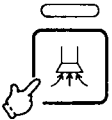

Crawl ON/OFF button ON



1) Correct the slewed paper fed from the paper feed section.

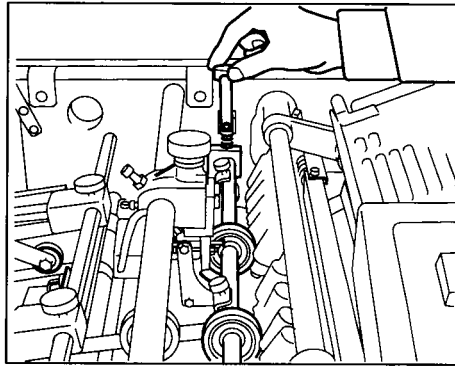

When the paper fed is slewed on the feeder board, adjust the pull-out roller pressure by using the adjustment knob.

2) Control the delivery air blower volume.

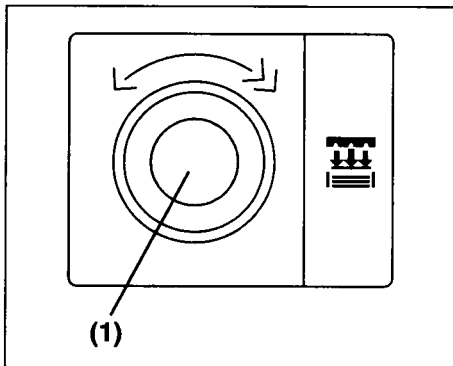

Control the delivery air blower volume by using the delivery air blower control knob (1).

When the paper drops strongly [1] or weakly [2], control the delivery air blower volume to drop the whole sheet equally [3].

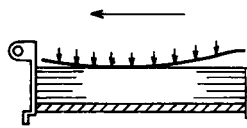

[1]

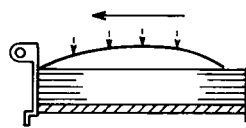

[2]

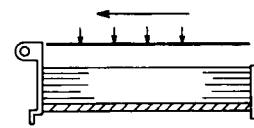

[3]

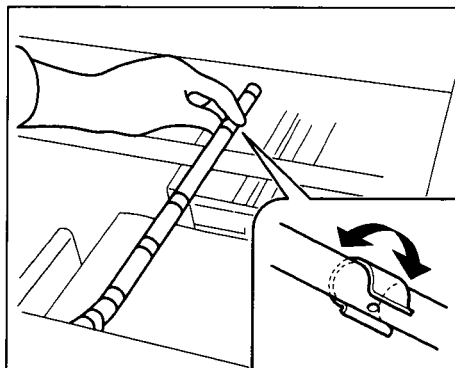

⚠ WARNING

Push the emergency stop button to stop the machine before adjusting. Failure to follow this instruction may result in a serious injury.

The delivery air blower nozzle can be opened or closed by turning the sleeve.

When printing on smaller size paper, close the unnecessary delivery air blower nozzle. Adjust the opening and closing of the nozzle depending on the delivery condition of the printed paper.

8. Setting the Ink Section

1) Set the ink fountain.

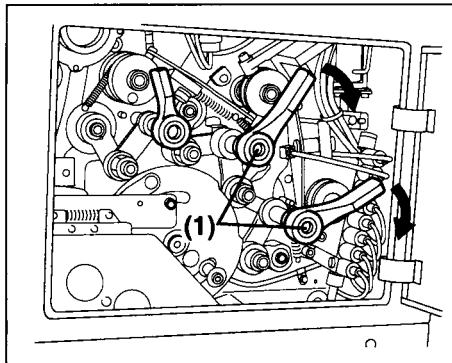

CAUTION

Stop the machine before setting. Failure to follow this instruction may result in an injury.



WARNING

Close the cover opened after setting. Failure to follow this instruction may result in a serious injury.

Open the non operation side cover and shift the ink form roller release lever (1) in the direction of the arrow. ( ,  position)
After setting the lever, close the cover opened.

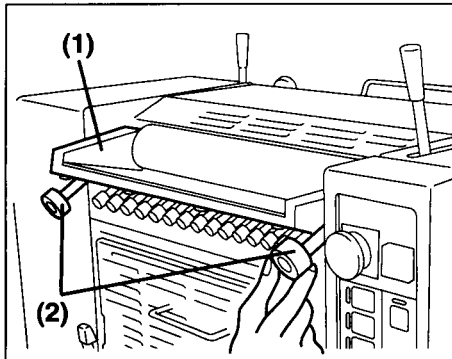

Push the ink fountain (1) against the ink fountain roller, and put the fixing knobs (2) into the brackets. Then tighten the knobs to fix the fountain.

<< NOTICE >>

When turning the ink fountain roller with no ink in the ink fountain, the ink fountain roller may be damaged, therefore please be careful.

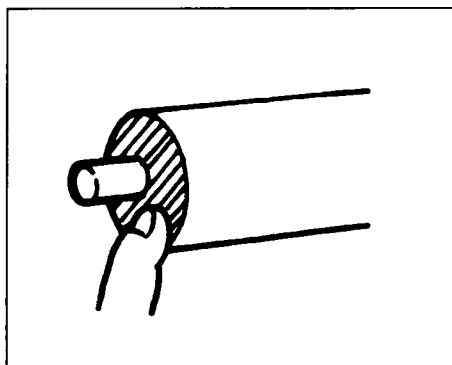

<< NOTICE >>

Before setting the ink fountain, wipe off any foreign particles in the ink fountain and on the ink fountain roller. Apply oil on the side edges of the ink fountain roller. This oiling assures smooth fountain roller rotation.

■ When feeding the ink to the ink rollers.

Drive button ON

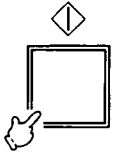

Ink ductor button ON

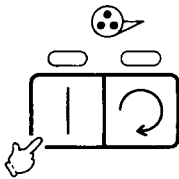

2) Control the ink feeding volume.

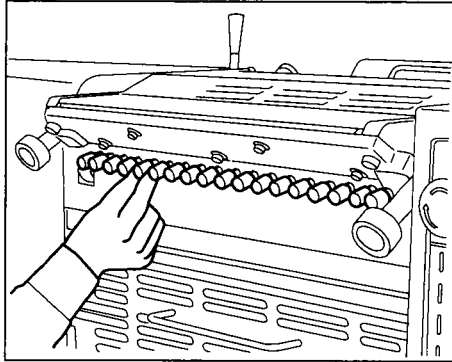

Put the ink in the ink fountain.

Control the ink feeding volume by using the screws to match the image.

When turning the screw in the clockwise direction, the ink feeding volume will be reduced.

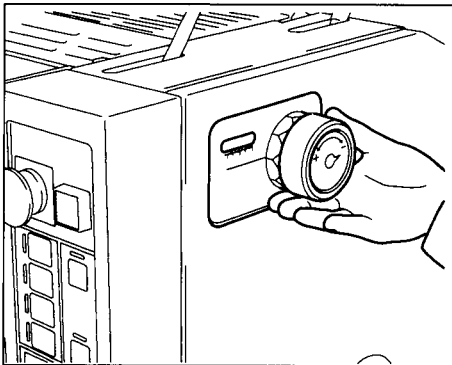

Run the machine and feed the ink to the rollers.

The total ink feeding volume is controlled by using the ink volume control dial.

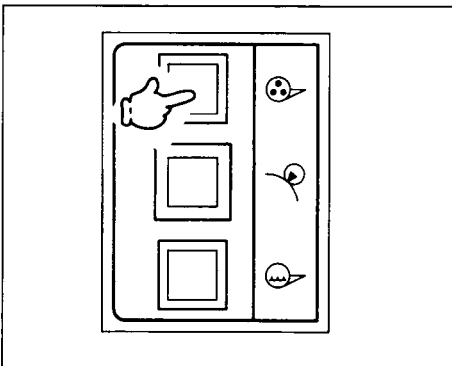

(Reference) While pushing the ink ductor manual ON button on each unit, the ink can be fed onto the rollers by operating the ink ductor roller.

9. Setting the Impression Pressure Adjustment Dial

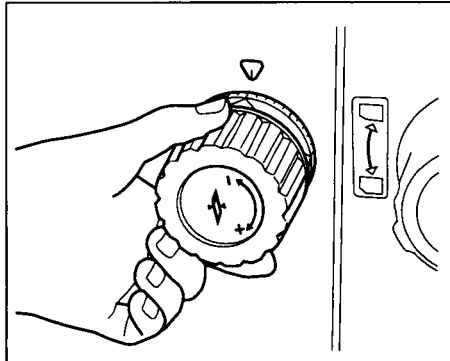

Set the impression pressure adjustment dial to match the paper thickness. The impression pressure may slightly differ depending on the surface of the paper and condition of the blanket, therefore adjust the impression pressure based on the printed material.

<< NOTICE >>

If printing with the dial scale set to a paper thickness less than the thickness of the paper being printed, the blanket and machine will be damaged.

10. Setting the Delivery Section Auxiliary Switch Panel

1) Set the each detector switch.

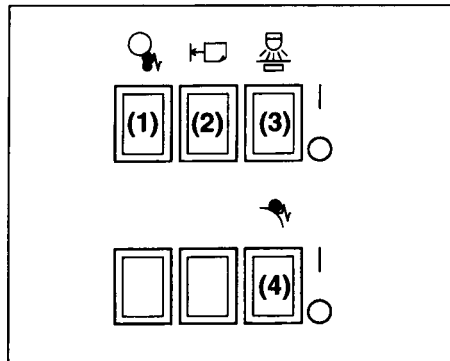

Set the paper feed jam detector switch (1), paper feed break detector switch (2), electronic type double sheet detector switch (3), and blanket jam detector switch (4) at the **I** position.

<< NOTICE >>

*If printing with the paper feed jam detector switch, paper feed break detector switch, electronic type double sheet detector switch, and blanket jam detector switch at the **O** position, the machine may be damaged.*

2) Set the cycle set button.

[Cycle type]

0	1	2	3	4
PRINT	A			B
5	6	7	8	9

There are the following cycles for the printing process.

(1) CY-0 ... Printing cycle

When printing, the cycle set button should be set on "0".

(2) CY-1 ... Wet cycle for the metal plate

This is the process that supplies dampening solution to the plate surface by contacting the water form rollers with the plate automatically before feeding paper only when pushing the printing start button with the set speed drive button off to print in the metal plate printing mode.

If this process is not properly done, scumming will occur when starting printing or too much dampening solution will be supplied.

(3) CY-2 ... Inking cycle

This is the process that supplies ink to the plate by contacting the ink form rollers with the plate automatically before feeding paper only when pushing the printing start button to print.

(4) CY-3 ... Blanket cleaning cycle

(5) CY-4 ... Wet cycle for the polyester plate

This is the process that supplies dampening solution to the plate surface by contacting the water form rollers with the plate automatically before feeding paper only when pushing the printing start button with the set speed drive button lighting to print in the polyester plate printing mode.

If this process is not properly done, scumming will occur when starting printing or too much dampening solution will be supplied.

(6) CY-8 ... Cycle for the service technician

(7) CY-9 ... Cycle for the maintenance and inspection

(Note) 1. CY-5, 6, and 7 have no function.

2. CY-8 and 9 are not necessary to set when printing.

3. CY-3 can be used on the machine with the blanket cleaning device.

[Cycle Indication]

Indication	Cycle type	Setting possible range	Setting pitch	Factory setting value
CY-1	Wet cycle for the metal plate	1 to 50 rotations	Every one rotation	2 rotations
CY-2	Inking cycle	1 to 10 rotations	Every one rotation	2 rotations
CY-3	Blanket cleaning cycle	20 to 65 rotations	Every five rotations	20 rotations
CY-4	Wet cycle for the polyester plate	1 to 50 rotations	Every one rotation	10 rotations

[Cycle setting procedures]

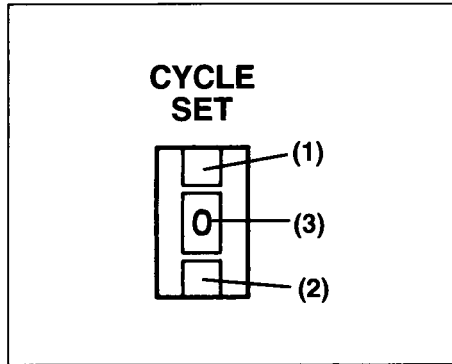

There are 2 cycle setting buttons (1) and (2).
When pushing either button, the cycle indication (3) in the middle changes and at the same time, the cycle indication and setting value will be indicated on the counter panel on the delivery section operation panel.

(Note) When pushing the button (1), the cycle set number is increased and when pushing the button (2), the cycle set number is reduced.
The numbers can be changed from 0 to 9.

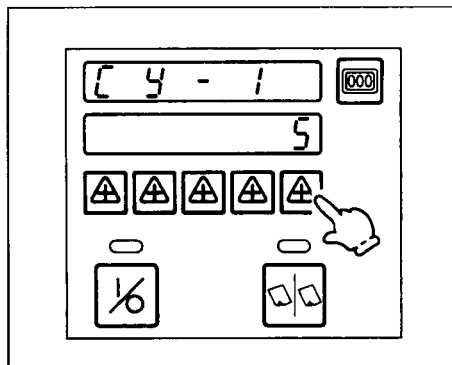

The setting value is set by using the counter set button on the delivery section operation panel.

Set the cycle setting value from the CY-1 to the CY-4 by repeating the operation above.

(Note) After completing the setting of the set value, return the cycle set button indication to "0".

11. Test Printing

1) Print and check the image position and color.

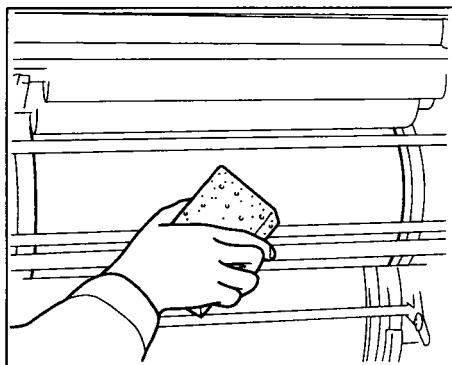

When using a metal plate, wipe off the gum solution on the plate surface using a sponge soaked with water.

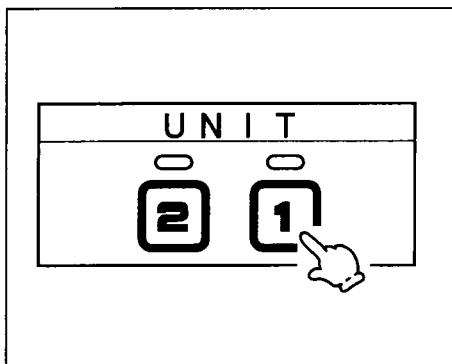

Check that the unit selection button of the unit used for printing is ON.

■ When doing the test printing ...

Drive button ON

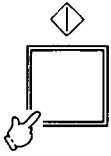

Printing start button ON



■ When completing the test printing ...

Production button OFF

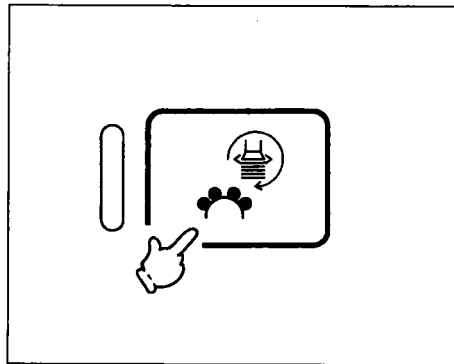

Run the machine and push the printing start button to start printing in the metal plate printing mode.

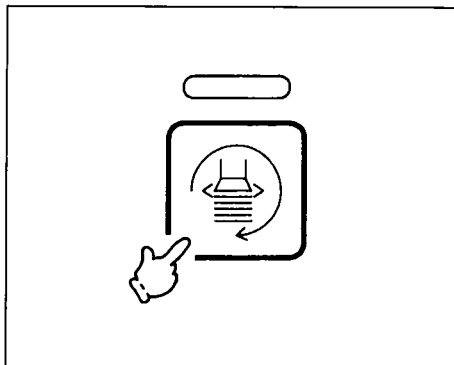

Push the production button on the delivery section operation panel to stop the paper feed. Check the image position and color on the printed sheet.

(Reference) When pushing the production button to stop the paper feed, the water form roller and ink form roller will release automatically from the plate surface.



12. Adjustment of the Image Position

<Diagonal image adjustment by moving the paper>

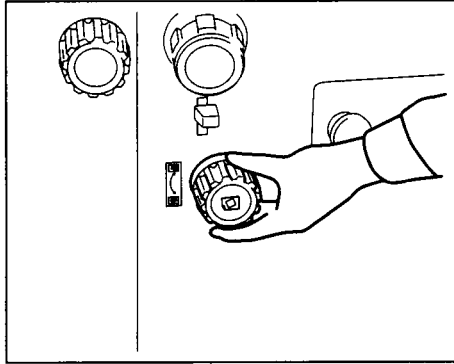

Turn the paper feed drum diagonal micro adjustment knob and move the non operation side of the paper to do the diagonal micro adjustment.

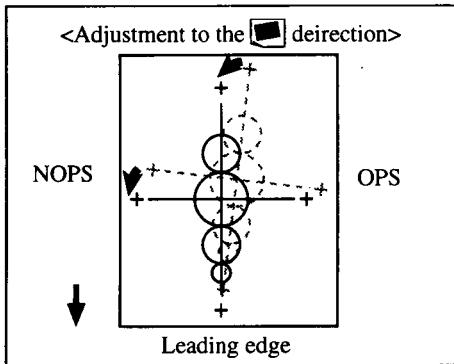

When turning the adjustment knob in the [] direction, the non operation side image will move toward the leading edge.

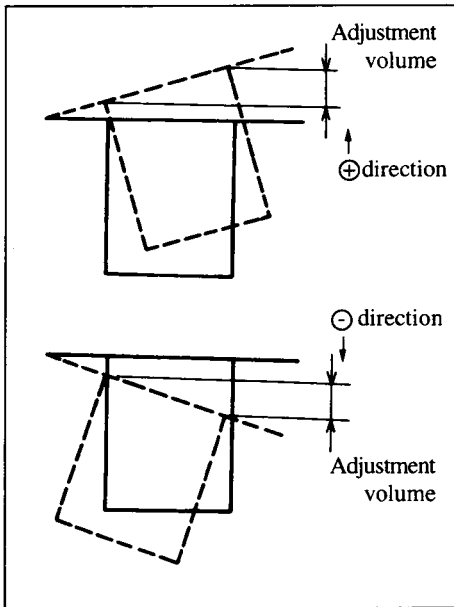

The adjustment volume differs depending on the paper size.

Paper size	Adjustment volume
A3 : 310 x 444 mm (12.20 x 17.48")	± 0.5 mm (0.02")
Postcard : 90 x 150 mm (3.54 x 5.91")	± 0.15 mm (0.006")

(Note) After doing this adjustment, the image micro adjustment should be done in the vertical direction.

<Diagonal image adjustment by moving the plate>

Adjustment example

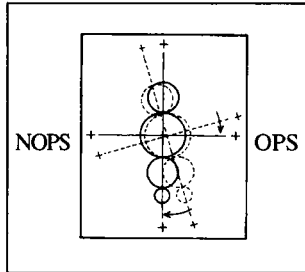

Here we will explain about moving the operation side image toward the leading edge.

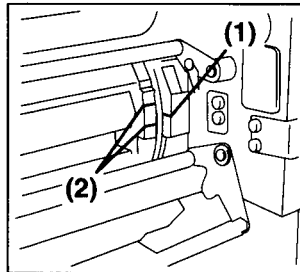

1. Push the crawl button so that the line (1) on the plate cylinder gear cover is between the 2 lines (2) on the plate cylinder.

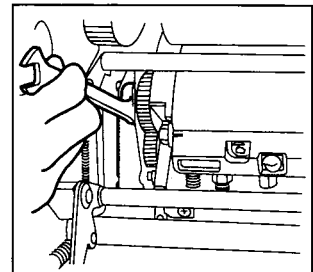

2. Loosen the quick tension bolt.

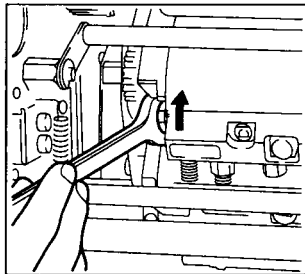

3. Move the clamp by turning the diagonal position adjustment bolt in the direction of the arrow.

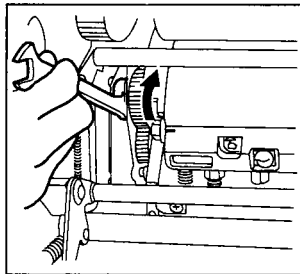

4. Tension the plate by turning the quick tension bolt in the direction of the arrow.

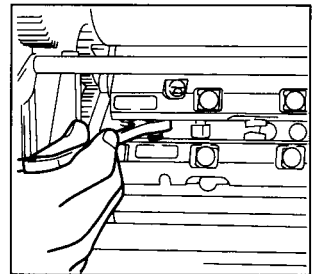

5. Tighten the leading edge plate tensioning bolt on the operation side.



CAUTION

Remove the wrench from the quick tension bolt before pushing the crawl button, when the plate cannot be tensioned properly at the plate cylinder gap position. Failure to follow this instruction may result in an injury.

<< NOTICE >>

When doing the diagonal image adjustment, the bolt (2) should not be turned past 2 scales on the plate cylinder lateral direction in the right or left direction from the standard position (1) on the scale.

When unable to do the diagonal image adjustment within the 2 scales on each side, consider that the image position is twisted toward the plate or the plate mounting position is twisted greatly. Another reason may be that the punch holes position is incorrect. Check the mounting position of the plate and image position on the plate.

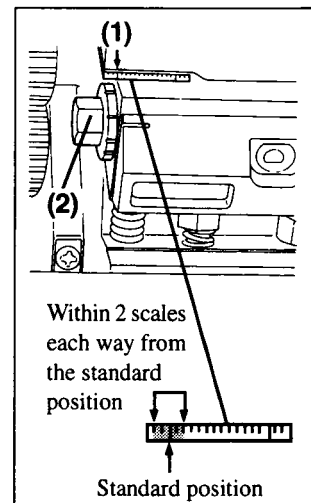

<Vertical image adjustment>

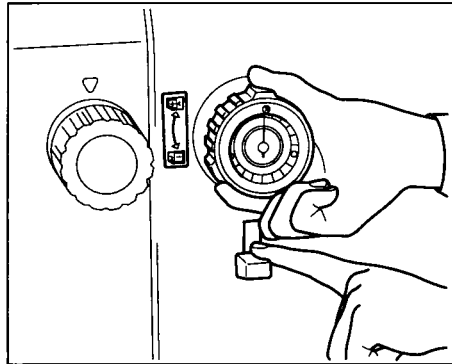

Stop the machine and push in the vertical image micro adjustment dial while pushing the clutch lever down. When releasing your hand from the clutch lever after pushing it down, the adjustment dial is engaged and the vertical image adjustment can be done.

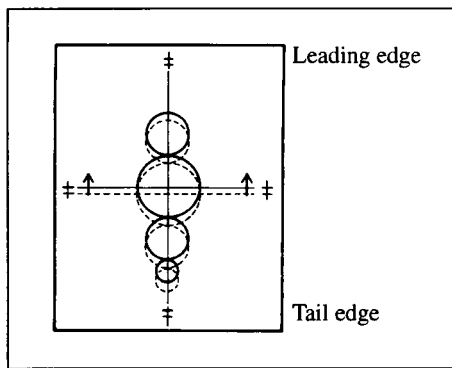

Turn the vertical image micro adjustment dial and do the vertical image position adjustment. The maximum movement volume is ± 20 mm (0.787"). When turning the adjustment dial in the "+" direction, the image will move toward the leading edge.

(Reference)

Turning the adjustment dial by one scale moves the image 0.25 mm (0.0098").

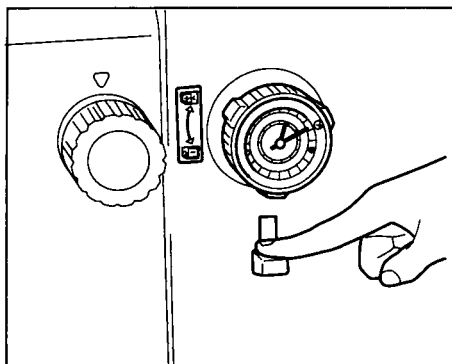
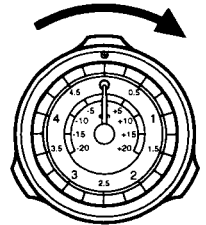

Push the clutch lever down again to release the vertical image micro adjustment dial lock.

(Note) When the adjustment dial is locked, a safety device actuates and the machine cannot be run.

<Lateral image adjustment>

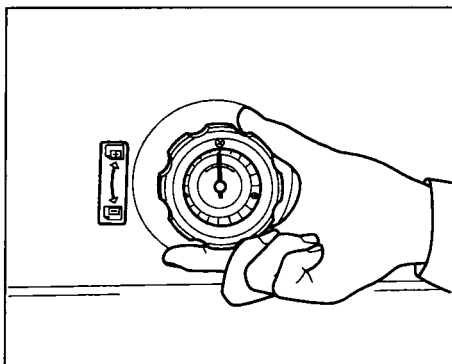

Turn the plate cylinder lateral image micro adjustment dial and do the lateral image position adjustment.

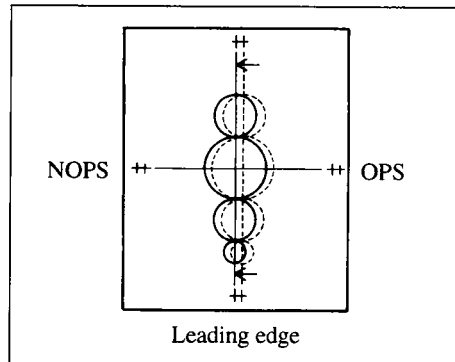

Turning the plate cylinder lateral image micro adjustment dial in the clockwise direction, the image will move toward the operation side.

(Reference)

Turning the adjustment dial by one scale moves the image 0.1 mm (0.004").

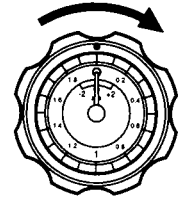

- (Note) 1. Do not adjust the lateral image position by using the plate cylinder lateral image micro adjustment dial during the printing.
 2. The maximum movement volume by using the plate cylinder lateral image micro adjustment dial is ± 2 mm (0.08"). If the image position cannot be adjusted within this range, change the plate exposing position.

<Lateral image adjustment by moving the paper>

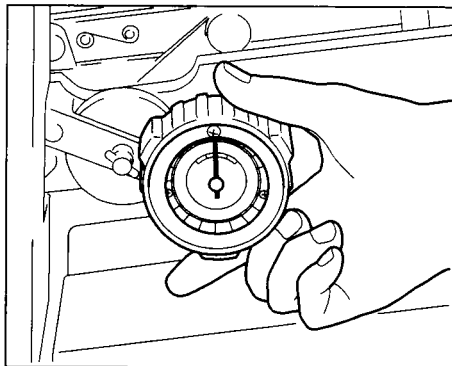

Turn the push side guide adjustment dial and do the paper lateral position adjustment. The maximum adjustment volume is ± 2 mm (0.08").

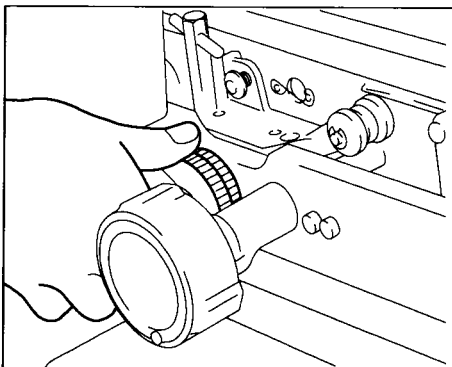

Adjust the flat spring (1) bending volume by turning the flat spring micro adjustment knob.

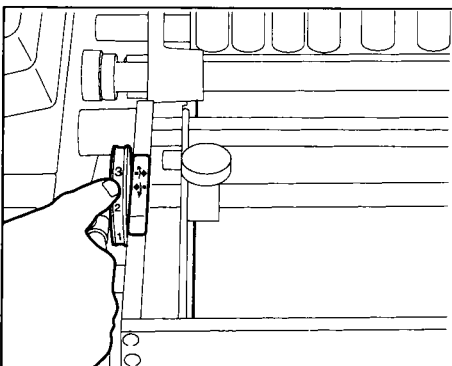
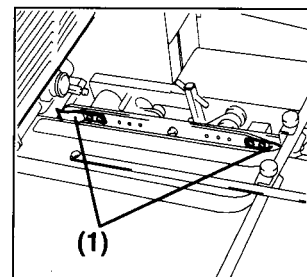

Adjust the piled paper lateral position by turning the side guide micro adjustment knob. Check the paper lateral position again.

13. Printing

1) Position the rotary guides.



WARNING

Push the emergency stop button to stop the machine before setting. Failure to follow this instruction may result in a serious injury.

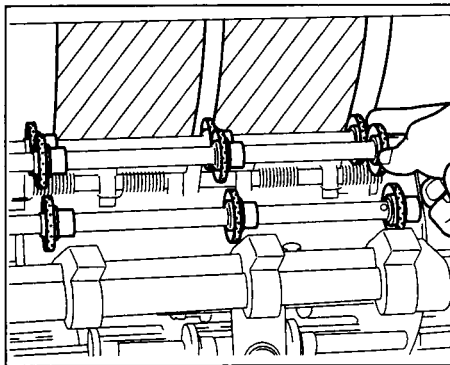

The rotary guides have to be moved to non image area positions.

2) Set the counter.

■ Counter setting procedures (P. 45)

Set the function mode by using the mode selection button.



Set the number of printed sheets or number of printed sheets per batch by using the counter setting buttons.



Count ON/OFF button ON

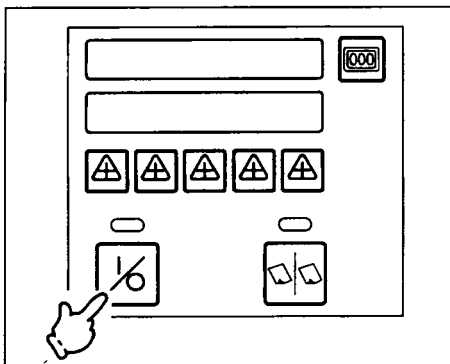

Input the required number of sheets and push the count ON/OFF button ON.

3) Print.

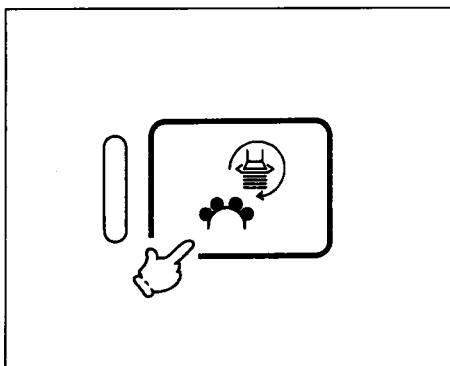

Clean the blanket and push the printing start button to start printing.

4) Set the powder spray device.

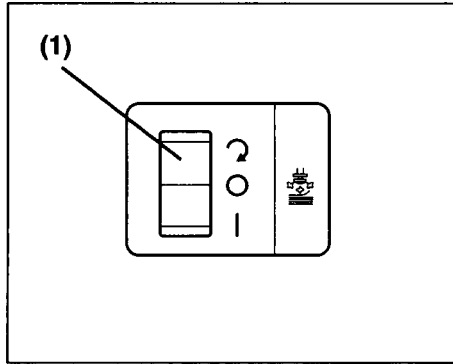

When setoff is likely to occur during printing, use the powder spray device. When setting the spray switch (1) at the  position, powder will be sprayed during printing.

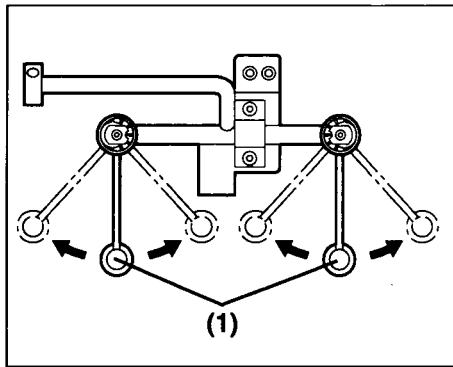

Adjust the position of the spray nozzles (1) to match the image on the printed sheet.

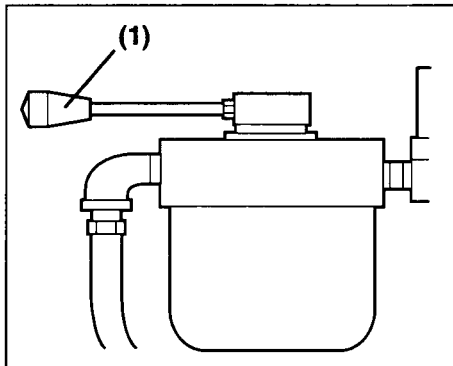

Control the total spray volume by using the spray volume control lever (1).

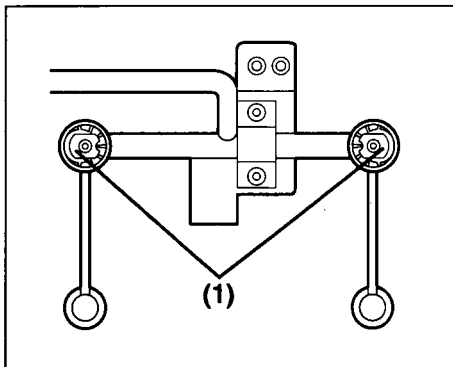

Turn the spray volume control plate (1) by using the wrench and control the powder spray volume outputted from each nozzle.



5) Pre-pile system



CAUTION

Stop the machine before setting. Failure to follow this instruction may result in an injury.

Exchanging the paper pile board

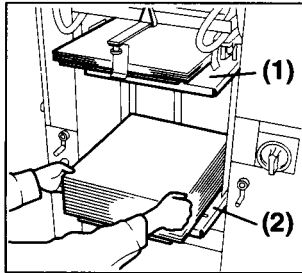

1. When the paper pile on the first paper pile board (1) becomes low, set the second paper pile board (2) on the second step and pile the paper.

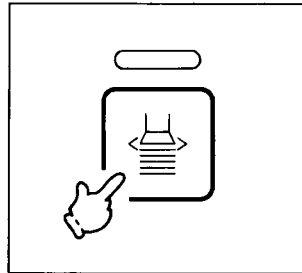

2. After the first paper pile is all printed, push the paper feed button OFF.

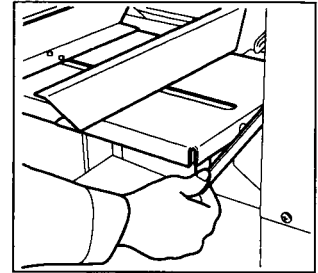

3. Lift the lever and remove the first paper pile board.

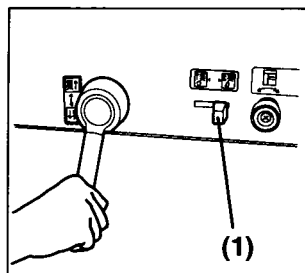

4. Set the release lever (1) at the  position and turn the crank handle and then elevate the second paper pile board.

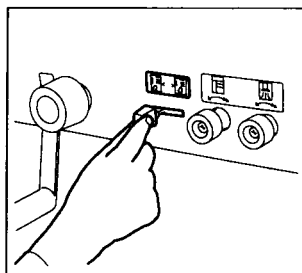

5. Set the release lever at the  position.

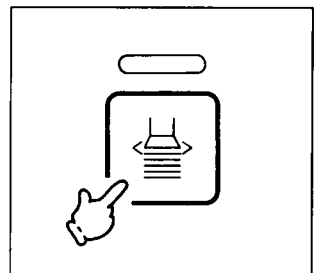

6. Push the paper feed button ON and start printing again.

Printing Finished

Printing Practice

2-1 Minimum Size Paper Printing (Point)

1) Setting the paper feed section



CAUTION

Stop the machine before setting. Failure to follow this instruction may result in an injury.

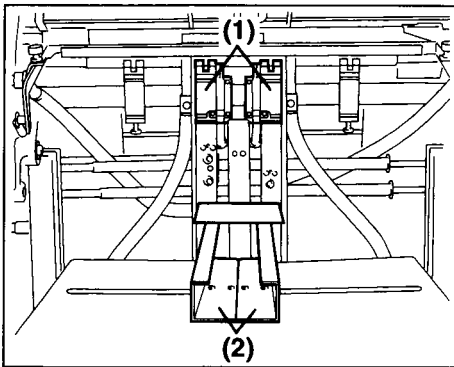

Use the 2 center sheet separators (1).

Center the paper pile board supports (2) and set a sheet of paper.

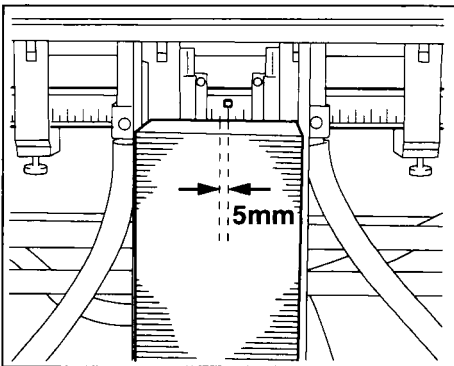

Set the vertical guides so that the center of the sheets is positioned 5 mm (0.197") from the center toward the operation side and pile the paper.

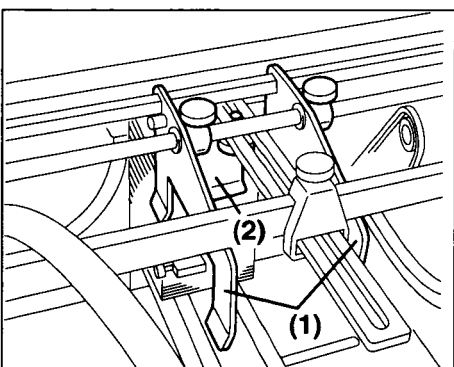

Set the side guides (1) and back guide (2).

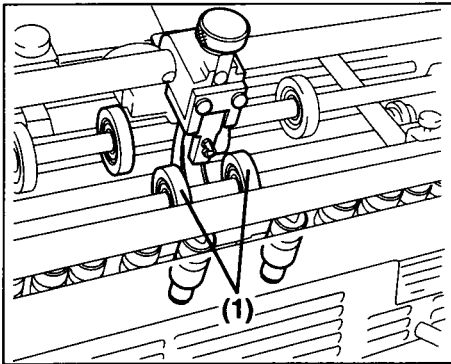

Set the pull-out rollers (1) on both sides of the double sheet detector (between the suction feet).
 Use the 2 central suction feet.
 Stop the vacuum of the suction feet not going to be used.
 Set the 2 central guide rollers according to the paper size.

2) Setting the feeder board



CAUTION

Stop the machine before setting. Failure to follow this instruction may result in an injury.

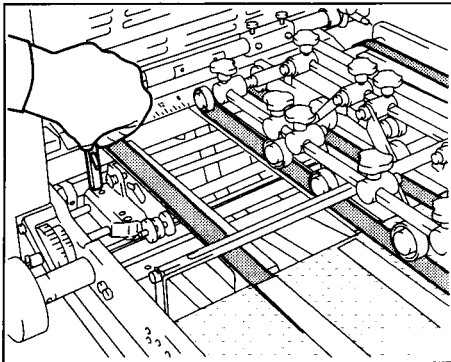

Loosen the board tape tension shaft and use the 2 inside board tapes.
 Remove the push side guide fixing screws at the operation side and non operation side and move the 2 outer board tapes to the outside of the push side guide.
 The 2 board tapes should be positioned on both edges of the minimum size paper.
 (Note) Please be careful not to set the board tape over the paper feed sensor.

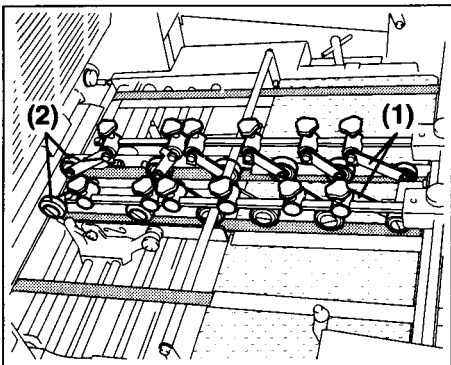

Set the skid rollers on the board tapes. 12 skid rollers are used.
 Set the skid rollers (1) with the long arm on the guide roller side.
 Set the skid rollers (2) with the spring on the paper feed drum side. (There are 2 types of the skid rollers for the operation side and non operation side.)
 Set the remaining skid rollers as shown in the illustration.
 (Note) One pair out of 6 pairs of skid rollers should contact always the paper until the paper arrives to the stop finger.

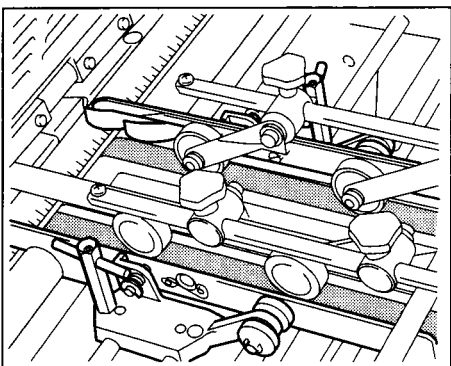

Set the push side guide and flat spring.
 Change the mounting position of the flat spring.

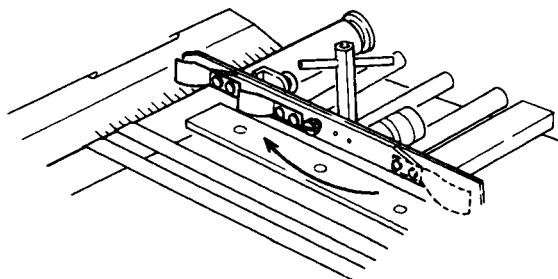

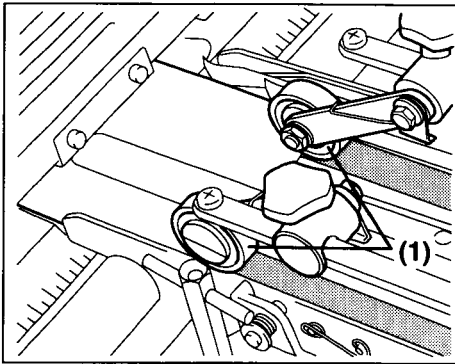

Set the skid rollers (1) at the tail edge of the sheet.

3) Setting the delivery section



WARNING

Push the emergency stop button to stop the machine before setting. Failure to follow this instruction may result in a serious injury.

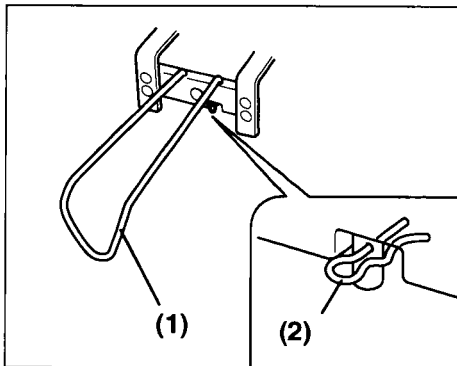

Mount the delivery guide (1) for the minimum size paper on the back guide.

And fix the guide by using the pin (2) so that the guide does not drop during the operation.

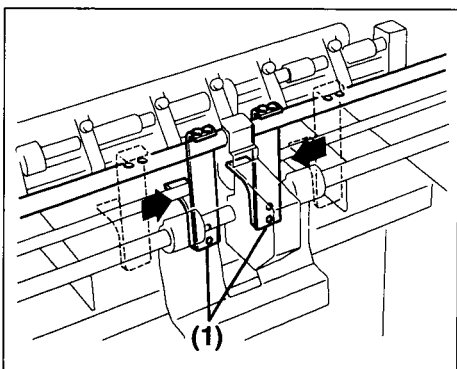

Change the paper drops (1) mounting position to the inside.

2-2 Thin Paper Feeding [Paper with a thickness less than 0.08 mm (0.0031'')] (Point)



CAUTION

Stop the machine before setting. Failure to follow this instruction may result in an injury.

1) Adjust the paper pile height.

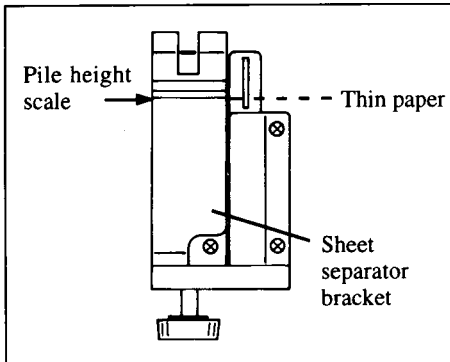

Adjust the paper pile height for the thin paper.

2) Set the suction feet and control the vacuum.

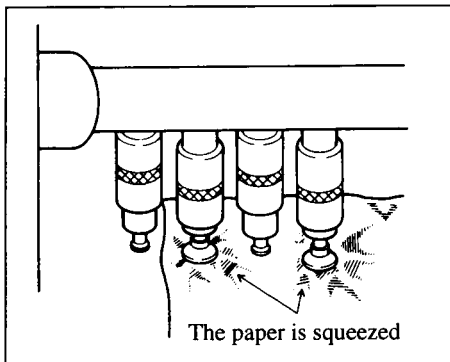

Please do not use the rubber suckers on the suction feet.

Control the vacuum to be as weak as possible.

(Note) If the rubber suckers or strong vacuum is used, the paper will be squeezed by the suction feet and will not be fed straight up to the pull-out rollers.

3) Control the center blower and side blower.

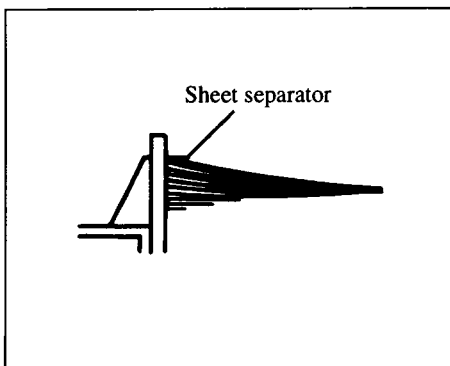

Control the center blower and side blower volume so that the top 5 to 6 sheets of paper are separated and so that the top sheet lightly contacts the sheet separator.

4) Control the auxiliary side blower.

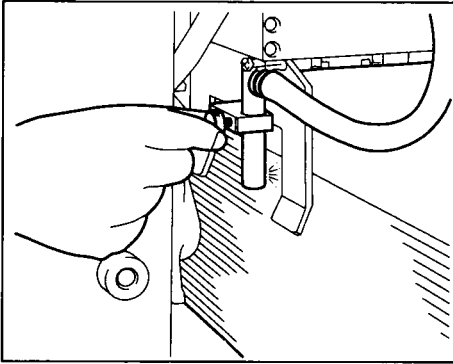

Control the auxiliary side blower volume to separate the top 5 to 6 sheets of paper.

5) Set the retainers.

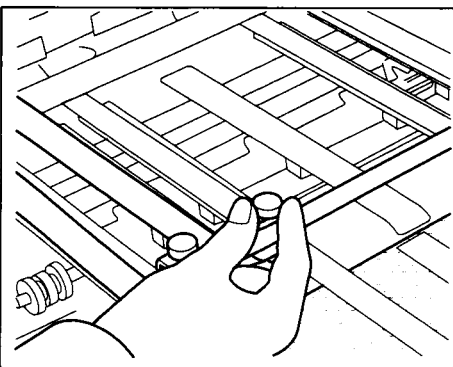

Use the retainers for thin paper.

6) Set the skid rollers.

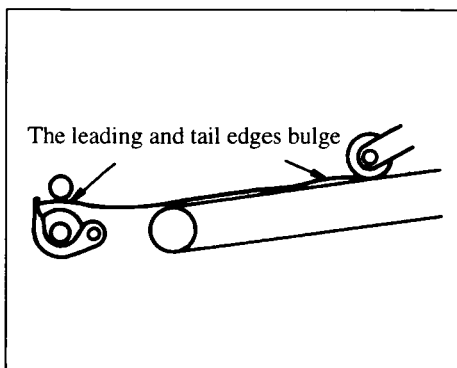

If the skid rollers are positioned too forward, the sheet of paper will bulge as shown in the illustration. Do not set the skid rollers like this.

7) Change the flat spring.

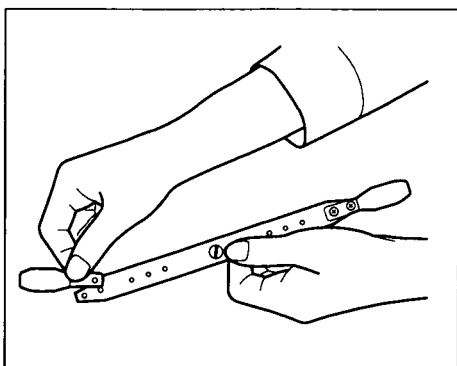

Change the flat spring on the paper feed drum side with the one for thin paper.

8) Control pushing volume.

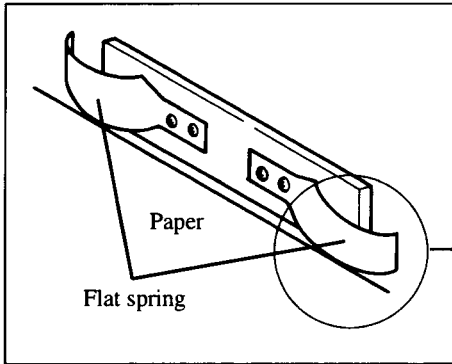

When the paper is pushed by the push side guide, the flat spring should bend about 0.5 mm (0.020").

(Note) If the pushing volume is too great, the paper will bulge as shown in the illustration below and stable lateral registration accuracy will not be possible.

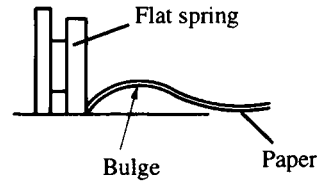

2-3 Paper Feed and Delivery of Curled Paper (Point)

1) Paper feed section

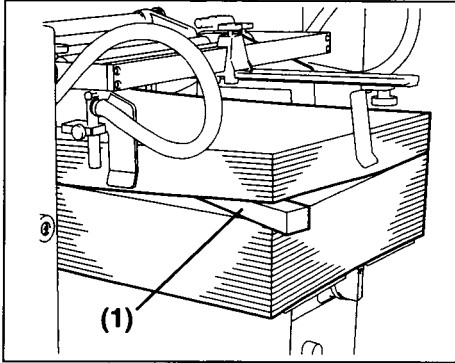

Control the curl of the paper and pile the paper.
Use a wedge (1) to make the top of the paper pile flat.

2) Delivery section

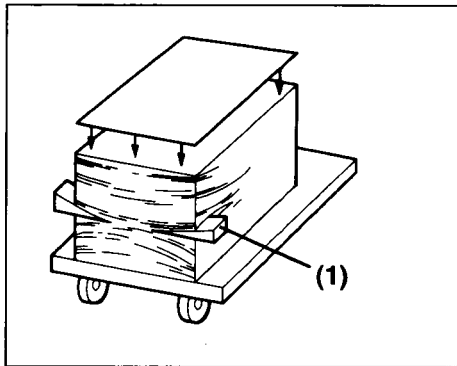

Use wedges (1) so that the whole sheet drops at the same time.

2-4 Polyester Plate Printing (Point)

For polyester plate printing, the press room environment has a greater influence compared with metal plate printing. Therefore, we recommend using the dampening solution cooling/circulation device (ECO15) to be able to keep the temperature of the plate surface from rising and to keep the dampening solution supply stable. As a countermeasure, we recommend adding isopropyl alcohol (IPA) (3 to 5 %) into the dampening solution.

1) Mount the polyester plate.

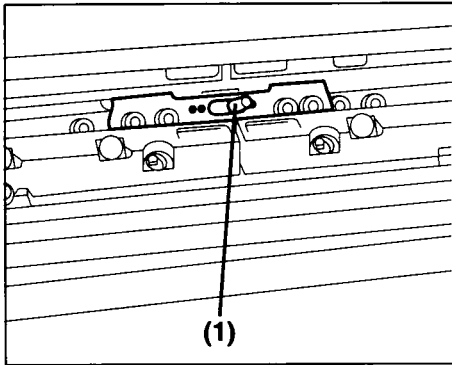

Set the plate clamp tension switchover lever (1) at the position.

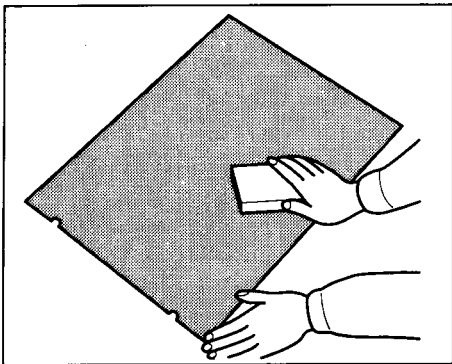

Before mounting the polyester plate, wipe off the plate surface by using dampening solution to remove any stains on the plate surface and to prevent ink from adhering when mounting the plate.

(Note) Please be careful not to wet the back side of the plate. If the back side gets wet, the plate may not move smoothly when doing the diagonal image adjustment causing a distortion of the plate.

2) Print.

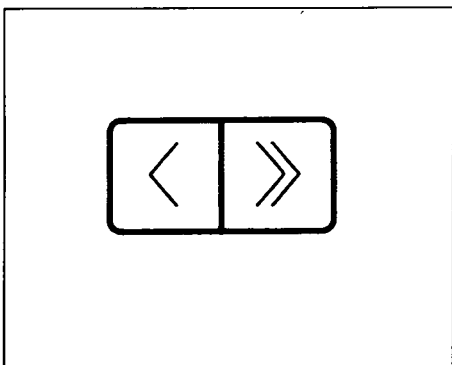

Push the speed set buttons at the same time and the speed indication is automatically set to "70".

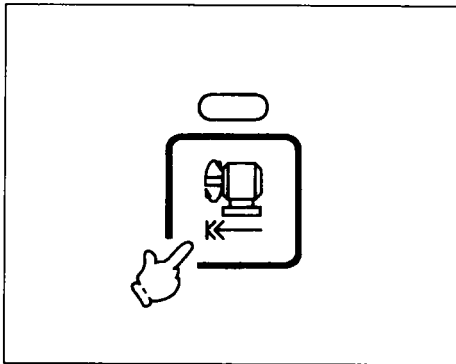

Run the machine, push the set speed drive button, and set the machine rotation speed to 7,000 RPH.

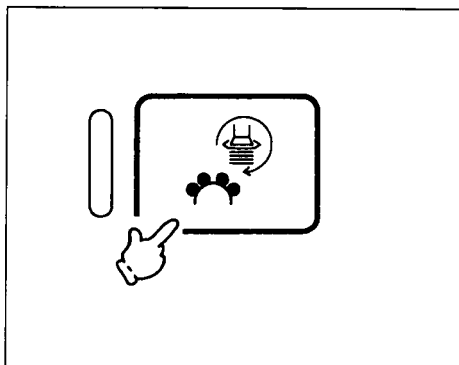

Push the printing start button to start printing in the polyester plate printing mode.

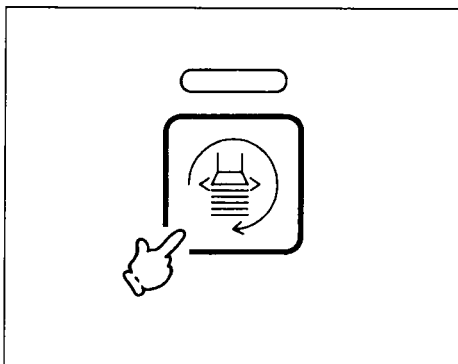

Push the production button on the delivery section operation panel and stop the paper feed.

2-5 Positioning the Image when Printing a Third Color and Fourth Color in 2 Passes (Point)

1) Do the third color printing and check the image position.

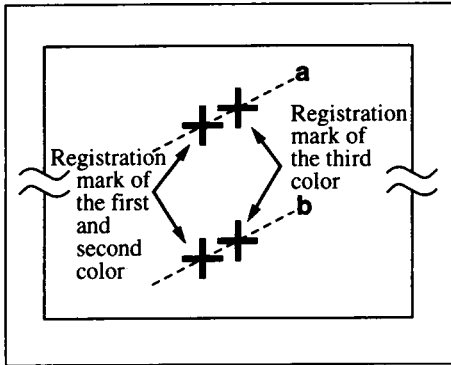

Check the distance from the center of the registration mark of the second color to the center of the registration mark of the third color on both the leading edge and tail edge sides.

- (1) Do the diagonal image adjustment so that “a” and “b” are parallel.
(Reference) Diagonal image adjustment by moving the paper (P.92)
Diagonal image adjustment by moving the plate (P.93)
- (2) Adjust the vertical direction.
(Reference) Vertical image adjustment (P.94)
- (3) Adjust the lateral position and align the registration marks.
(Reference) Lateral image adjustment (P.94)
Lateral image adjustment by moving the paper (P.95)

2) Do the fourth color printing and check the image position.

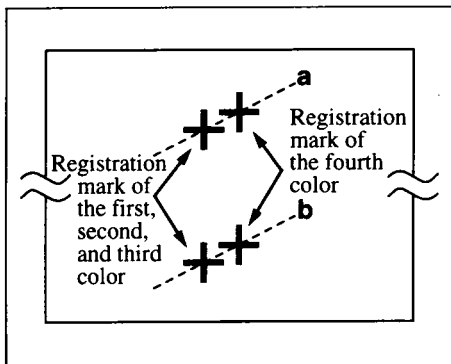

- (1) Do the diagonal image adjustment so that “a” and “b” are parallel.
(Reference) Diagonal image adjustment by moving the plate (P.93)
- (2) Adjust the vertical direction.
(Reference) Vertical image adjustment (P.94)
- (3) Adjust the lateral position and align the registration marks.
(Reference) Lateral image adjustment (P.94)

Maintenance Edition

This edition is composed of Chapter 1 “Maintenance after the Printing”, Chapter 2 “Periodic Inspection”, Chapter 3 “Periodic Maintenance”, Chapter 4 “Replacing the Supplies”, and Chapter 5 “Troubles and Countermeasures”.

Maintenance after the Printing

<< NOTICE >>

Be sure to do the maintenance after the printing to keep the machine in top operation condition.

1. Cleaning the Ink Section

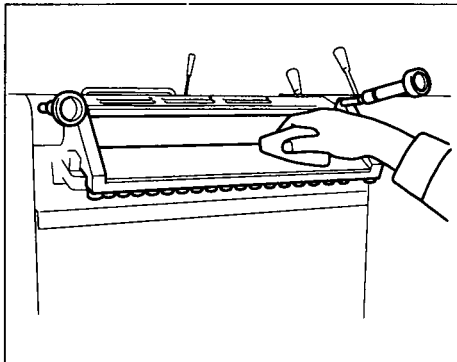

WARNING

Stop the machine before cleaning the ink fountain and ink fountain roller. Failure to follow this instruction may result in a serious injury.

Remove the ink in the ink fountain.

Loosen the ink fountain fixing knobs and pull the ink fountain downwards. Clean the side edges of the ink fountain roller, both sides of the ink fountain, and fountain blade edge well.

<< NOTICE >>

1. Do not use any powerful corrosive acid or chlorine type cleaning solution on the metal. The metal may corrode when the acid or chlorine reacts with the water.

Example of powerful corrosive chemicals:

Plate cleaner (powerful acid)

Blanket cleaner (chlorine type)

2. If the machine will not be operated for 3 days or more, apply the rust preventive oil on the ink fountain roller after cleaning it. Also if the printing room environment is one with a high temperature and damp, the metal will easily corrode and rust. Therefore in this environment when not using the machine the following day, apply the rust preventive oil on the ink fountain roller after cleaning it.

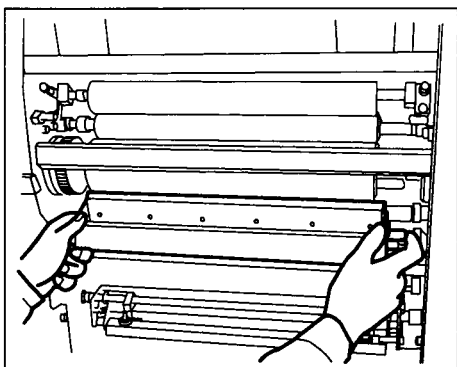

Mount the ink roller cleanup attachment on the bracket.

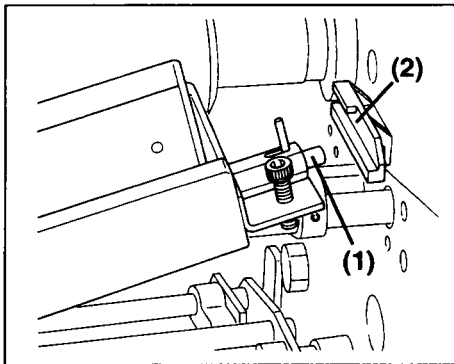

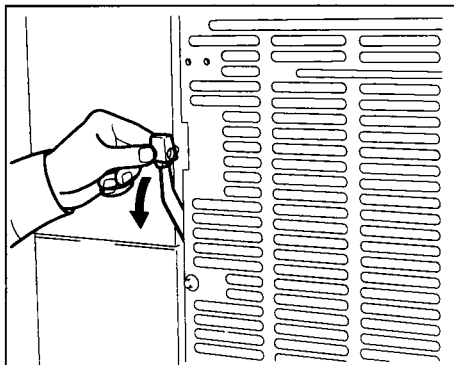

<< NOTICE >>

Insert the pins (1) of the ink roller cleanup attachment into the pin holes on the bracket (2) exactly. If it is not set properly, when running the machine, the ink roller cleanup attachment will drop and this will cause an accident.

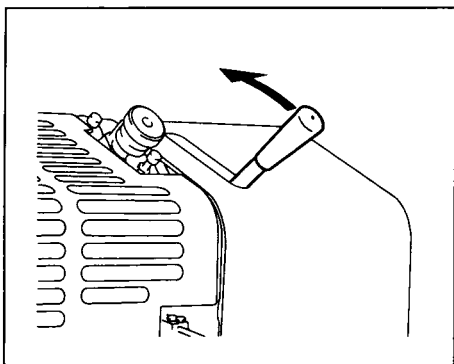

Run the machine and apply the cleaning solution on the rollers evenly, then shift the ink roller cleaning lever in the direction of the arrow (down).



Shift the metering roller release lever in the direction of the arrow ( position) to release the metering roller from the water fountain roller and water oscillating roller.

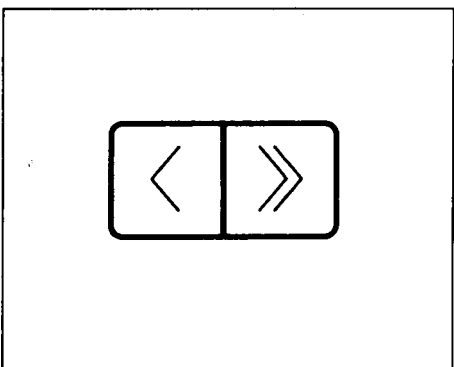

Push the speed set buttons at the same time and the speed indication is automatically set to "70".

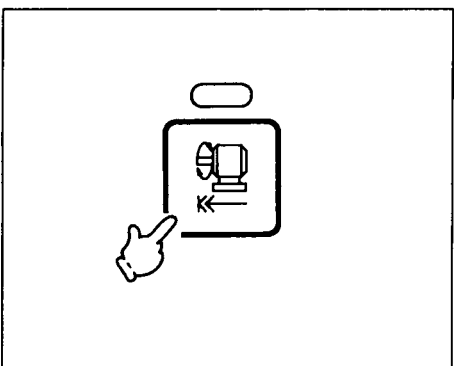

Push the set speed drive button. The machine rotates at a speed of 7,000 RPH.

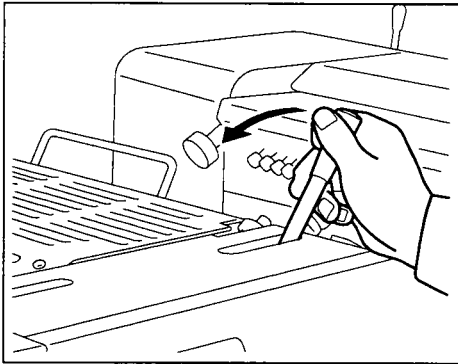

When the ink roller cleaning is almost completed, shift the water roller cleaning lever in the direction of the arrow ( position) to contact the bridge roller on the water oscillating roller.

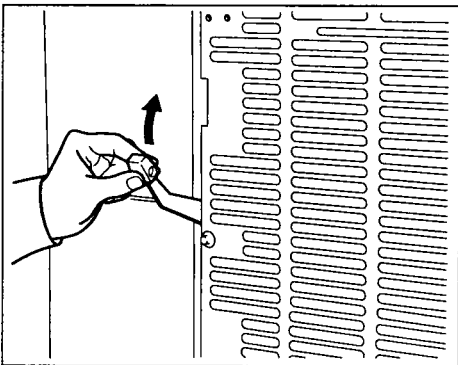

After cleaning the ink rollers and water form roller well, return the ink roller cleaning lever in the direction of the arrow (up) and water roller cleaning lever to the  position and stop the machine. After stopping the machine, wipe off the paper dust and foreign particles on the rollers.

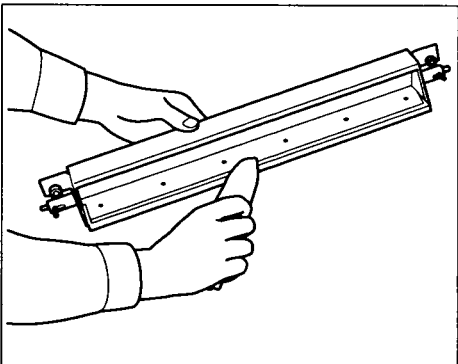

Remove the ink roller cleanup attachment and carefully clean it.

<< NOTICE >>

1. After finishing the ink roller cleaning, be sure to remove the ink roller cleanup attachment immediately.
If the ink roller cleanup attachment blade edge contacts the dry ink oscillating roller while the machine is running, it will damage the ink oscillating roller and ink roller cleanup attachment blade and cause the machine trouble.
2. If ink adheres on the ink roller cleanup attachment blade edge and it dries, it will wear out and damage the roller.
Be sure to clean the blade edge well.
3. Never expose the ink roller cleanup attachment to ultraviolet rays (i.e. direct sunlight). This will cause the blade to harden.

2. Cleaning the Water Section

1) Remove the water control wiper.

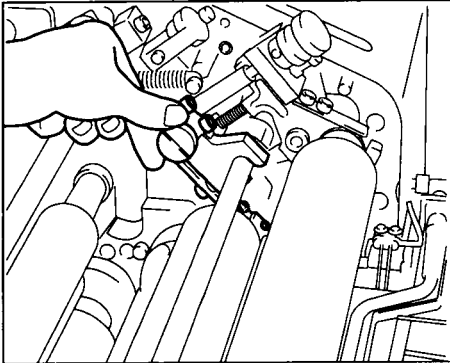

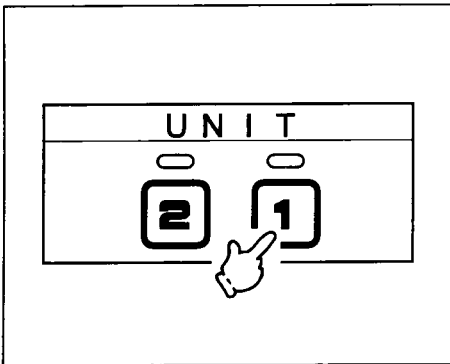

When cleaning the metering roller, be sure to remove the water control wiper.

2) Clean the metering roller.

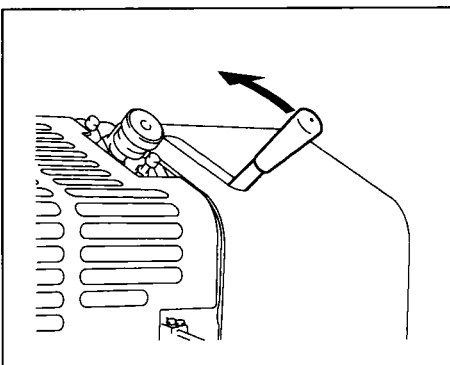

Turn all the unit selection buttons OFF to stop the metering roller rotation.



Shift the metering roller release lever in the direction of the arrow ( position) to release the metering roller from the water fountain roller and water oscillating roller.

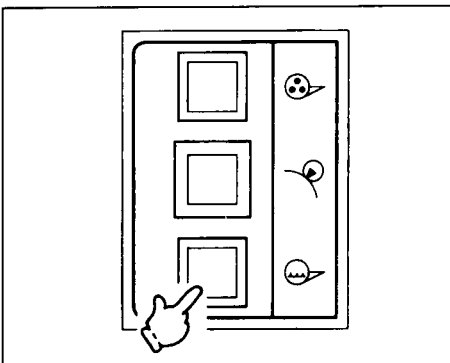

While pushing the water roller crawl button, the metering roller will rotate at crawl speed.

<< NOTICE >>

If pushing the water roller crawl button while the metering roller contacts the water fountain roller and water oscillating roller, the metering roller will be damaged.

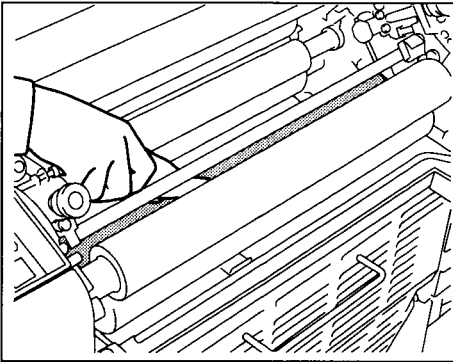

Wipe off all the ink that is adhered on the metering roller using the exclusive cleaner for the continuous dampening rubber rollers.

<< NOTICE >>

Release the metering roller by using the metering roller release lever after completing the daily operation to prevent deformation of the metering roller shape.

3) Clean the water fountain roller and water oscillating roller.

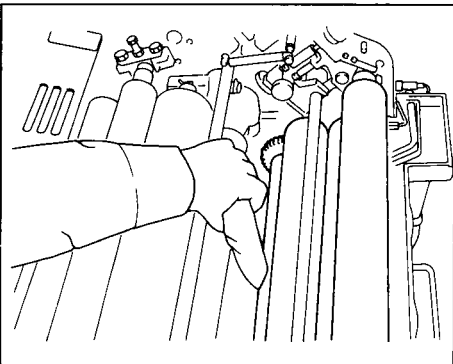

WARNING

Stop the crawl operation before cleaning. Failure to follow this instruction may result in a serious injury.

When completing the daily operation, clean the water fountain roller and water oscillating roller by using the exclusive cleaner for the continuous dampening metal rollers.

4) Do the roller maintenance to keep the hydrophilic properties of the roller surface.

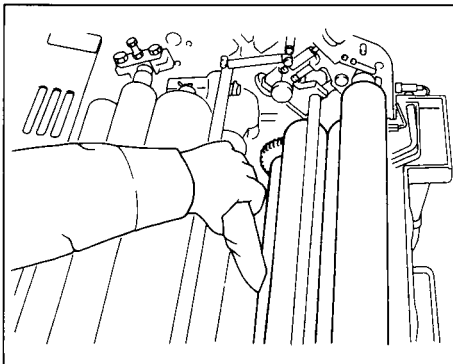

WARNING

Stop the crawl operation before doing the maintenance. Failure to follow this instruction may result in a serious injury.

When completing the daily operation, do the roller maintenance to keep the hydrophilic properties of the roller surface by using the exclusive cleaners for the rubber rollers and metal rollers of the continuous dampening system.

<< NOTICE >>

Do not use polishing powder and glaze remover, because the roller surface will be damaged.

5) Release the water rider oscillating roller from the water form roller.



CAUTION

Stop the machine before releasing. Failure to follow this instruction may result in an injury.

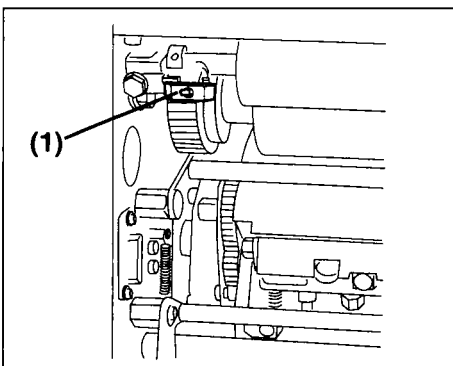

Set the water rider oscillating roller release knob (1) at the 3 o'clock position by turning it and pull the water rider oscillating roller by hand toward you so that it is properly released from the water form roller.

3. Cleaning the Cylinder Section



WARNING

Stop the crawl operation before cleaning. Failure to follow this instruction may result in a serious injury.

The materials that are used with the printing machine have a high degree of acidity and alkali which have a negative effect on the machine. The use of these strong chemicals may cause the metal parts to corrode or rust, so proper maintenance of the machine is very important after finishing the operation for the day. Because the cylinder section greatly influences the printing quality, proper maintenance should be done on it every day.

1) Clean the plate cylinder.

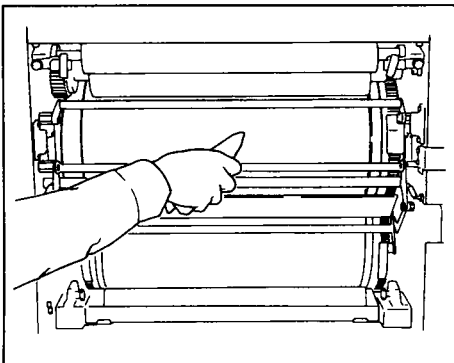

Take off the plate and under sheet from the plate cylinder after printing is finished. Wipe off any stains such as ink, etching solution, and plate cleaner on the plate cylinder surface with a cotton rag containing water and cleaning solution.

Also, when using the gauge film with the plate cylinder, take off the gauge film and clean the plate cylinder at least once a month.

<< NOTICE >>

1. *Do not use plate cleaner to clean the plate cylinder. When cleaning the plate, be careful that the plate cleaner does not adhere on the plate cylinder surface.
If the plate cleaner adheres on the plate cylinder surface, wipe it off with a cotton rag containing water and cleaning solution immediately.*
2. *When using the gauge film with the plate cylinder, clean the cylinder surface well and dry it completely before mounting the gauge film. Also, mount the gauge film so that it contacts the entire surface of the cylinder. If there is any clearance between the film and cylinder, water, etching solution, and the other chemicals will enter into the clearance and rust will form.*
3. *When the hydrophilic properties of the plate surface cannot be kept, wipe off any ink and oil with a cotton rag containing chrome roller cleaner. Then wipe off the chrome roller cleaner completely with a cotton rag containing water.*

2) Clean the blanket cylinder.

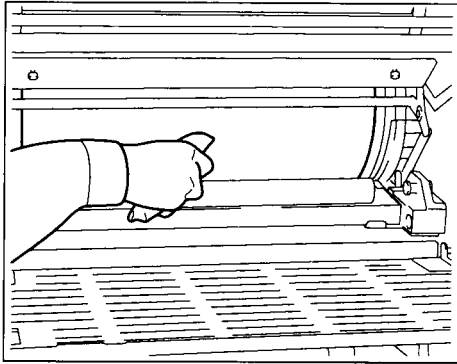

Wipe off any ink and etching solution on the blanket surface and side with a cotton rag containing water and cleaning solution.

Take off the blanket from the blanket cylinder and wipe off any stains such as ink and etching solution on the blanket cylinder surface with a cotton rag containing water and cleaning solution at least once a month. Make sure that the cylinder is completely dry, and then apply rust preventive oil over the entire surface of the blanket cylinder. Also, when using the gauge film with the blanket cylinder, take off the gauge film and clean the blanket cylinder at least once a month.

<< NOTICE >>

1. Be careful that the blanket recovery solution and other chemicals do not adhere on the blanket cylinder surface. If they adhere on the blanket cylinder surface, wipe them off with a cotton rag containing water and cleaning solution immediately. Make sure that the cylinder is completely dry, and then apply rust preventive oil over the entire surface of the blanket cylinder.

2. When using the gauge film with the blanket cylinder, clean the cylinder surface well and dry it completely before mounting the gauge film.

Also, mount the gauge film so that it contacts the entire surface of the cylinder. If there is any clearance between the film and cylinder, water, etching solution, and the other chemicals will enter into the clearance and rust will form.

3) Clean the impression cylinder.

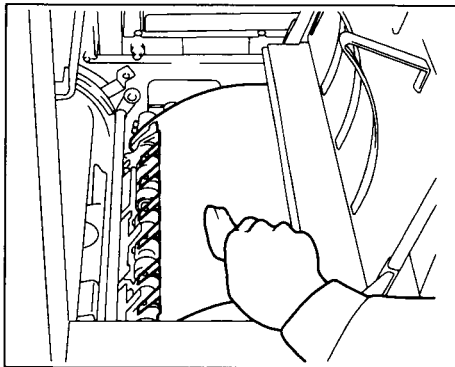

Wipe off any stains such as ink and etching solution on the impression cylinder surface with a cotton rag containing water and cleaning solution after printing is finished.

[Recommended rust preventive oil list]

Maker	Trade name
E. F. Houghton & Co.	Rust Veto 371, 377
Daubert Chemical Co.	Nox-Rust 307
Valvoline Oil Co.	Tectyl 894

(Note) The recommended rust preventive oil is equivalent to the MIL (Military specifications and standards), P-3 type.

(Please use the rust preventive oil that displaces water.)

4. Plate Preservation

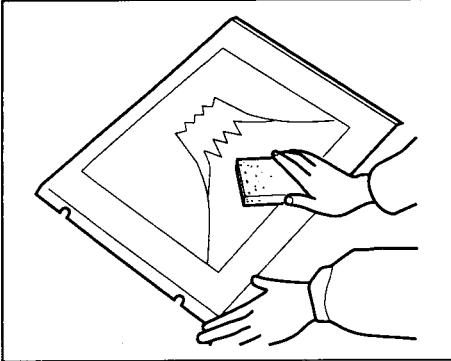

To use the metal plate over again, correct plate preservation is necessary.

1. Using a sponge soaked with water, apply water onto the plate surface. Then using cleaning solution, wash off the ink on the plate surface and then rinse the plate surface with water.
2. Apply the metal plate protection ink on the plate after dampening the plate surface.
3. First rinse it with water, then dry it, then apply gum solution and finally dry it.

<< NOTICE >>

Check each section periodically to keep the machine in top operating condition.

1. Checking the Roller Pressure

The roller pressure has a great influence on the printing results and ink roller cleaning. Check the pressure at the minimum of once every 3 months.

1) Checking and adjustment of the ink form roller pressure



WARNING

1. Never touch the rotating parts when doing the crawl operation.
 2. Close the cover opened after finishing the inspection.
- Failure to follow these instructions may result in a serious injury.

Checking the roller pressure

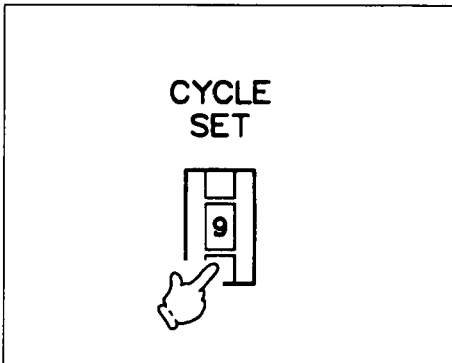

Push the cycle set button on the delivery section auxiliary switch panel and set it to the cycle "9".

(Note) When setting it to the cycle "9", the ink form roller and water form roller will be in contact with the plate surface when the machine is stopped. When checking and adjusting the form roller pressure, the cycle should be set on "9". After completing the adjustment, the cycle should be returned to "0".

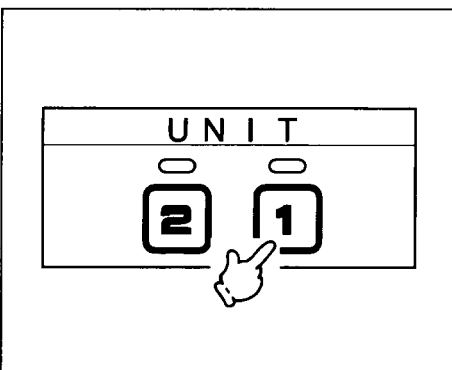

Push the unit selection button of the unit on which the roller pressure adjustment will be done.

(Note) The checking and adjustment should be done on every unit.

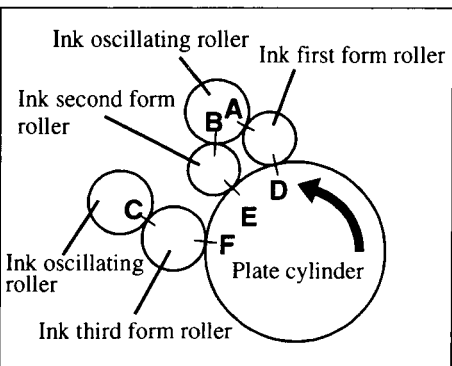

Sign	Nip width (mm) (inch)	Sign	Nip width (mm) (inch)
A	3.0 (0.118")	D	3.5 (0.138")
B	3.0 (0.118")	E	3.5 (0.138")
C	3.0 (0.118")	F	3.5 (0.138")

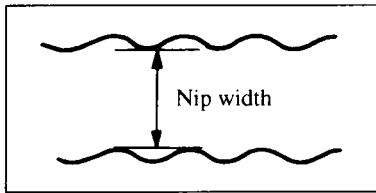



(Note) The nip width should be measured both on the operation and non operation sides after transferring it onto a sheet of paper. Adjust so that both sides nip widths are the same and equal the standard value.

(Note) When adjusting the pressure between the ink form roller and ink oscillating roller, the pressure with the plate will change. (However even when adjusting the pressure with the plate, the pressure with the ink oscillating roller will not change.) Therefore adjust the pressure with the ink oscillating roller first, and after that, adjust the pressure with the plate.

a. The pressure between the ink form roller and ink oscillating roller (A, B, C)

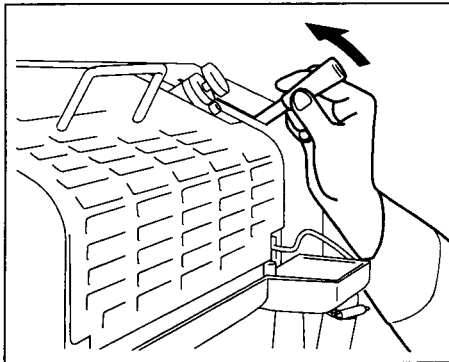
Checking procedures



Shift the metering roller release lever in the direction of the arrow ( position) to release the metering roller from the water oscillating roller.

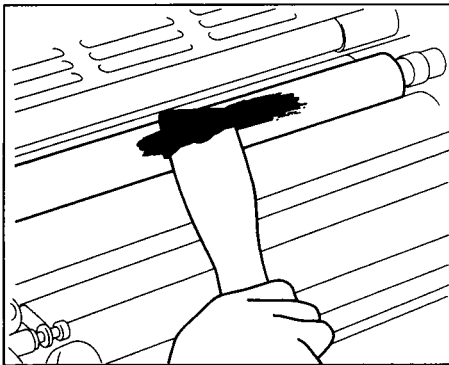

Apply ink on the roller thinly and run the machine.

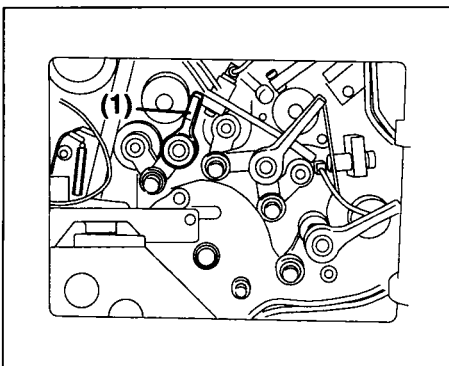

Set the water form roller release lever (1) at the  position.

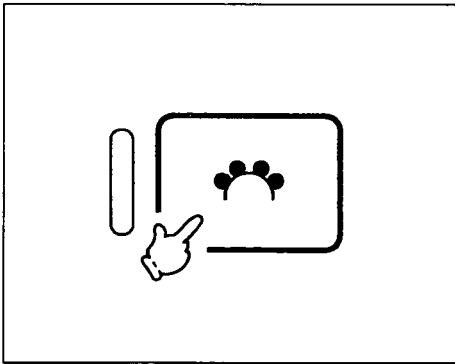

Push the water and ink form roller ON button to contact the ink form rollers with the plate surface.

(Note) If the water sensor does not detect the dampening solution in the water fountain, the water and ink form roller ON button cannot be turned ON.

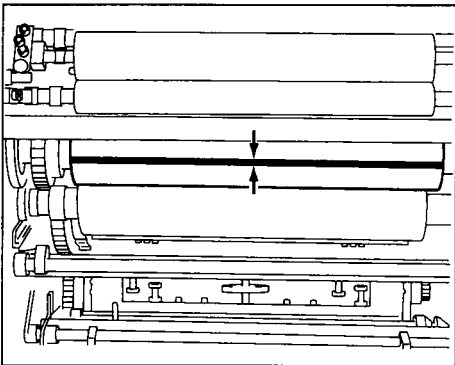

After running the machine for a few minutes, stop the machine. After a few seconds, push the crawl button and check the nip width on the ink oscillating roller.

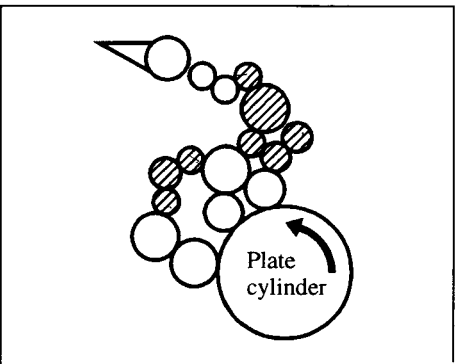

(Reference) The nip width should be checked after removing the distributor rollers shown by the diagonal lines in the illustration.

<Adjustment procedures>

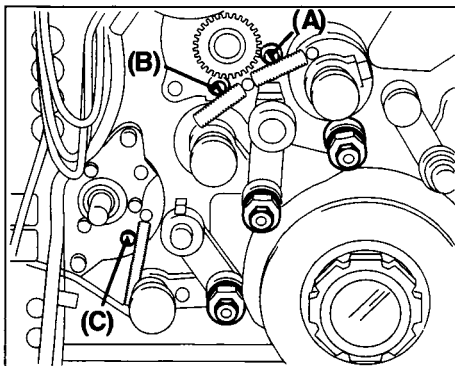

Turn the adjustment screws (A), (B), and (C) to adjust them.

The adjustment screws are located at the 3 places each on the operation and non operation sides. When turning them in the “+” direction (in the counterclockwise direction), the pressure will be increased.

- Ink first form roller and ink oscillating roller (A)
- Ink second form roller and ink oscillating roller (B)
- Ink third form roller and ink oscillating roller (C)

b. The pressure between the ink form roller and plate (D, E, F)

Checking procedures

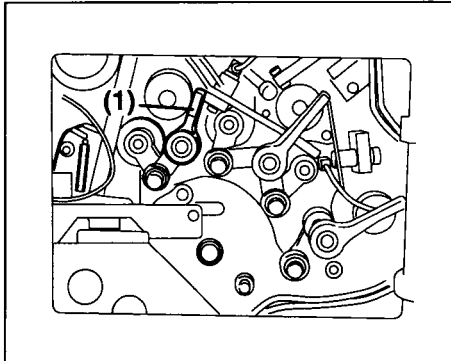

Set the water form roller release lever (1) at the  position.

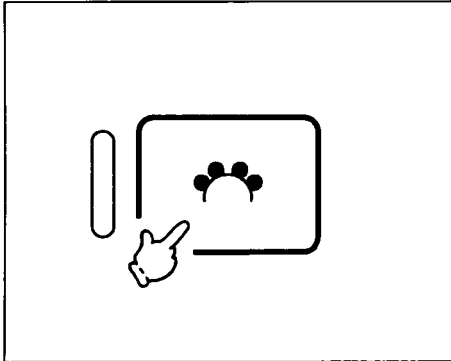

Run the machine and push the water and ink form roller ON button to contact the ink form roller with the plate surface.

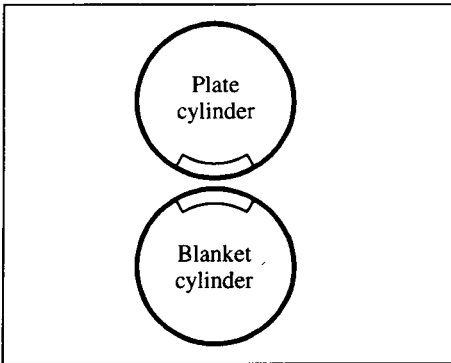

After running the machine a few minutes, stop it. (Stop at the position where the plate cylinder gap faces the blanket cylinder gap.)

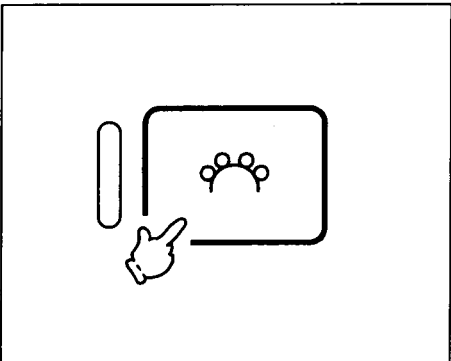

After a few seconds, push the water and ink form roller OFF button to release the ink form roller from the plate surface.

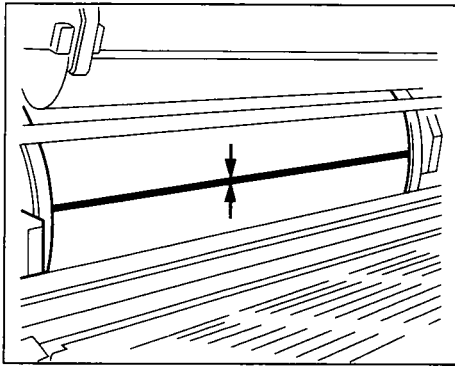

Push the crawl button and then check the nip width that appears on the plate surface.

<Adjustment procedures>

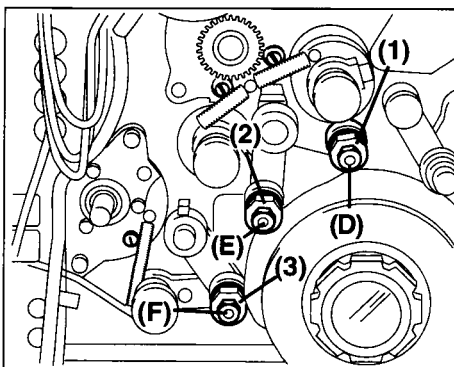

Loosen the lock nuts (1), (2), and (3) and turn the pressure adjustment nuts (D), (E), and (F) to adjust them.

The adjustment nuts are located at the 3 places each on the operation and non operation sides. When turning them in the direction of the arrow, the pressure will be increased.

- Ink first form roller and plate (D)
- Ink second form roller and plate (E)
- Ink third form roller and plate (F)

2) Checking and adjustment of the water roller pressure

WARNING

1. Never touch the rotating parts when doing the crawl operation.
 2. Close the cover opened after finishing the inspection.
- Failure to follow these instructions may result in a serious injury.

Checking the roller pressure

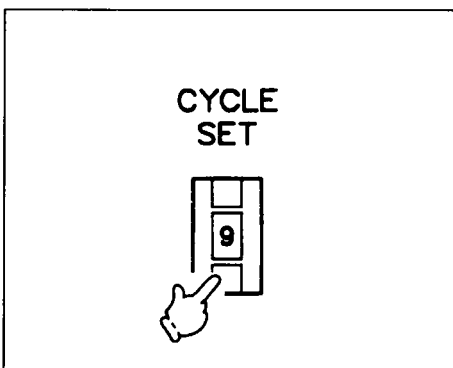

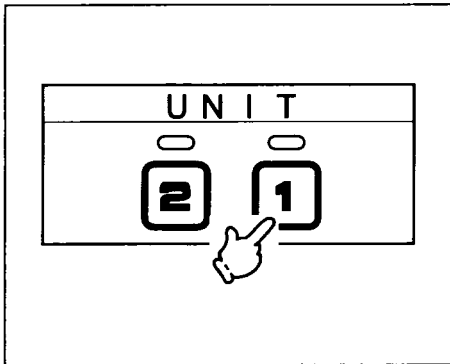

Push the cycle set button on the delivery section auxiliary switch panel and set it to the cycle "9".

(Note) When setting it to the cycle "9", the ink form roller and water form roller will be in contact with the plate surface when the machine is stopped. When checking and adjusting the form roller pressure, the cycle should be set on "9". After completing the adjustment, the cycle should be returned to "0".

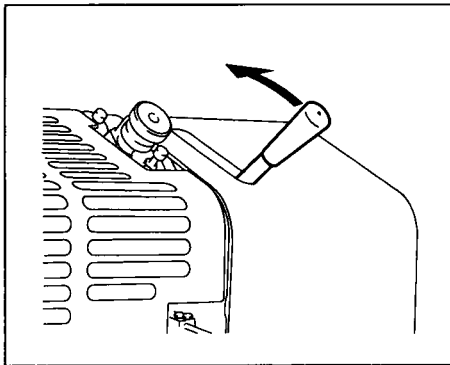

Push the unit selection button of the unit on which the roller pressure adjustment will be done.
 (Note) The checking and adjustment should be done on every unit.



Shift the metering roller release lever in the direction of the arrow ( position) to release the metering roller from the water oscillating roller.

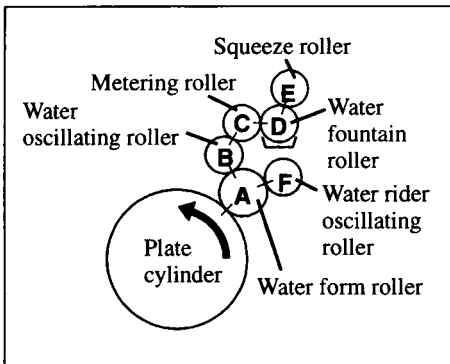

Sign	Nip width (mm) (inch)	Sign	Nip width (mm) (inch)
A	4.0 (0.157")	D	—
B	2.0 (0.079")	E	Parallel pressure
C	2.0 (0.079")	F	Parallel pressure

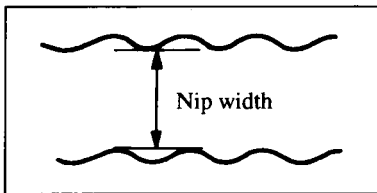

(Note) The nip width should be measured both on the operation and non operation sides after transferring it onto a sheet of paper. Adjust so that the nip widths on both sides are the same and equal the standard value.

(Note) When adjusting the pressure between the water form roller and water oscillating roller, the pressure with the plate will change. (However even when adjusting the pressure with the plate, the pressure with the water oscillating roller will not change.) Therefore adjust the pressure with the water oscillating roller first, and after that, adjust the pressure with the plate.

a. The pressure between the water form roller and water oscillating roller (B)

Checking procedures

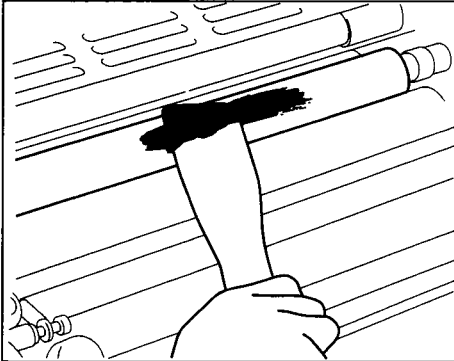

Apply ink on the roller thinly and run the machine.
Feed the ink to the water roller by shifting the water roller cleaning lever.

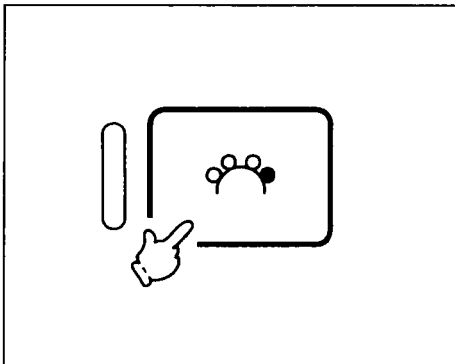

Push the water form roller ON button to contact the water form roller with the water oscillating roller.

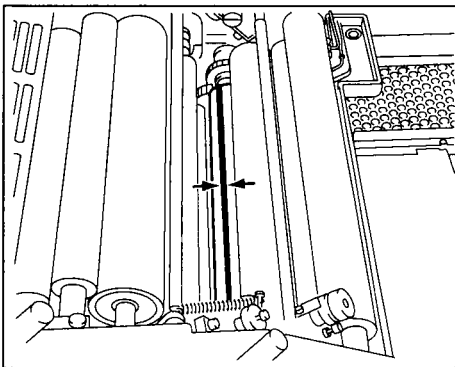

After running the machine for a few minutes, stop the machine.
After a few seconds, push the crawl button and check the nip width on the water oscillating roller.

<Adjustment procedures>

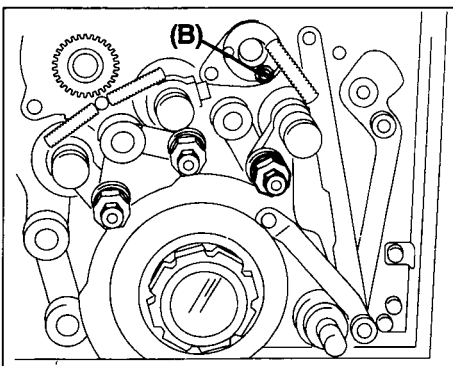

Turn the adjustment screw (B) to adjust it.
The screw is located on both the operation and non operation sides. When turning it in the “+” direction (in the counterclockwise direction), the pressure will be increased.

b. The pressure between the water form roller and plate (A)

Checking procedures

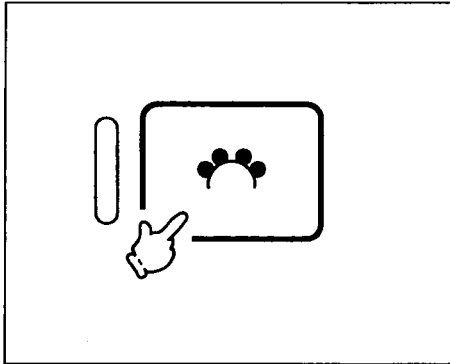

Apply ink on the roller thinly and run the machine. Push the water and ink form roller ON button to contact the water form roller with the plate surface.

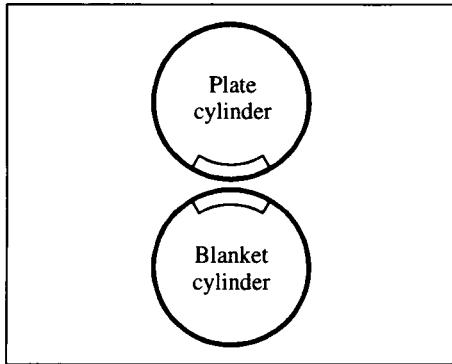

After running the machine a few minutes, stop it. (Stop at the position where the plate cylinder gap faces the blanket cylinder gap.)

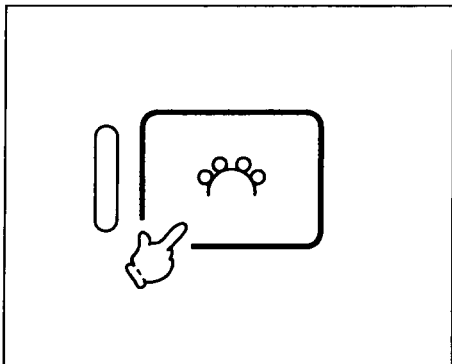

After a few seconds, push the water and ink form roller OFF button to release the water form roller from the plate surface.

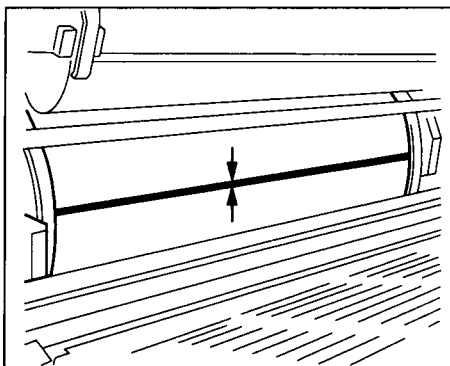

Push the crawl button and then check the nip width that appears on the plate surface.

<Adjustment procedures>

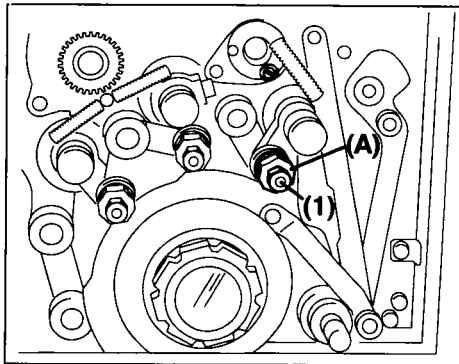

Loosen the lock nut (1) and turn the pressure adjustment nut (A) to adjust it.
When turning the adjustment nut (A) in the direction of the arrow, the pressure will be increased.

c. The pressure between the metering roller and water fountain roller (D)

<Checking and adjustment procedures>

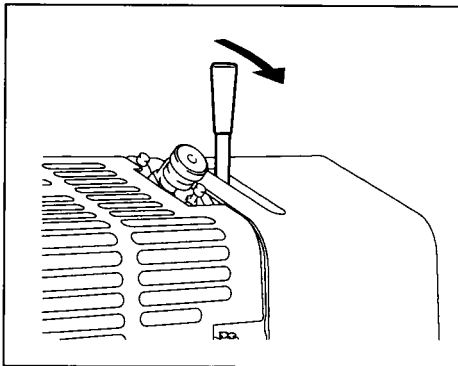

Check that the dampening solution is supplied into the water fountain until the dampening solution contacts the water fountain roller.
Shift the metering roller release lever in the direction of the arrow ( position) to contact the metering roller with the water fountain roller.

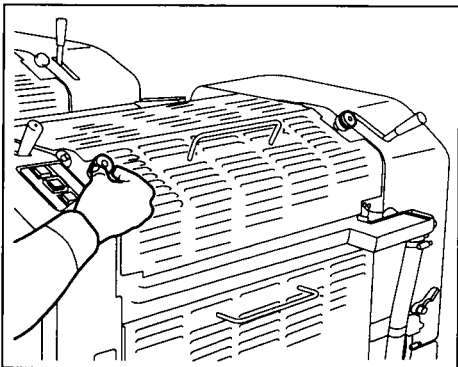

Run the machine and turn the metering roller pressure adjustment knob in the “-” direction (in the clockwise direction) one complete turn and release the pressure.
After that, turn the adjustment knob in the “+” direction (in the counterclockwise direction) slowly until the aqua film on the metering roller just cuts.
Then turn the adjustment knob in the “+” direction (in the counterclockwise direction) 10 clicks more from the position that the aqua film was cut.

d. The pressure between the metering roller and water oscillating roller (C)

Checking procedures

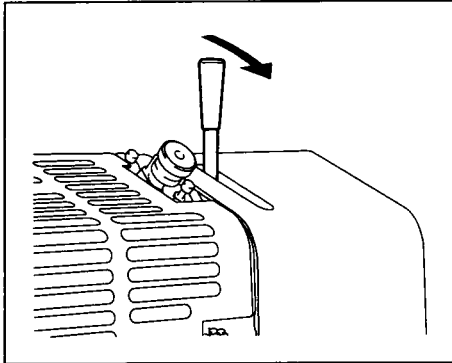

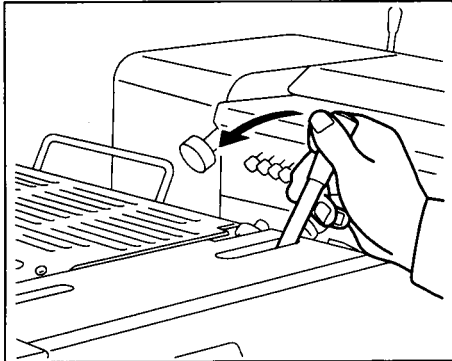

Shift the metering roller release lever in the direction of the arrow ( position) to contact the metering roller with the water fountain roller.

At this time, set the water volume control dial to "0".



Run the machine.

Shift the water roller cleaning lever in the direction of the arrow ( position) and contact the bridge roller with the water oscillating roller, to apply ink on the water oscillating roller.

After that, shift the water roller cleaning lever back to the  position.

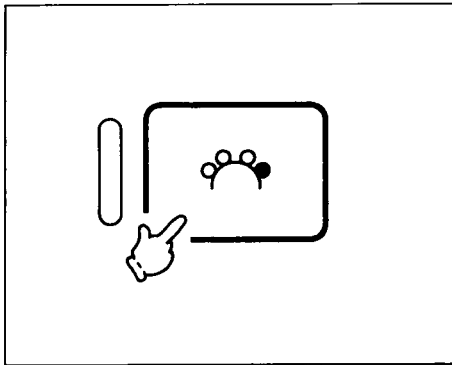

Stop the machine.

Push the water form roller ON button to contact the metering roller with the water oscillating roller.

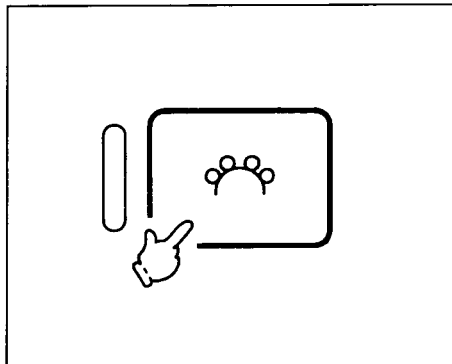

After a few seconds, push the water and ink form roller OFF button to release the metering roller from the water oscillating roller.

<< **NOTICE** >>

Be sure to push the water and ink form roller OFF button to release the metering roller from the water oscillating roller. If rotating the rollers with the metering roller contacting the water oscillating roller, the metering roller surface and water fountain roller motor will be damaged.

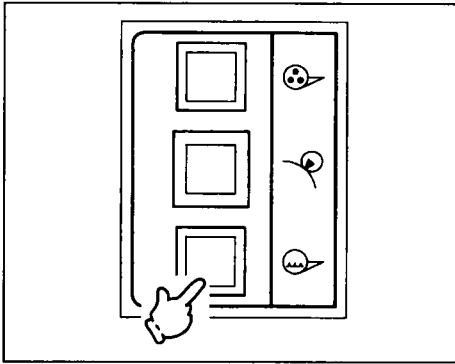

Push the water roller crawl button.

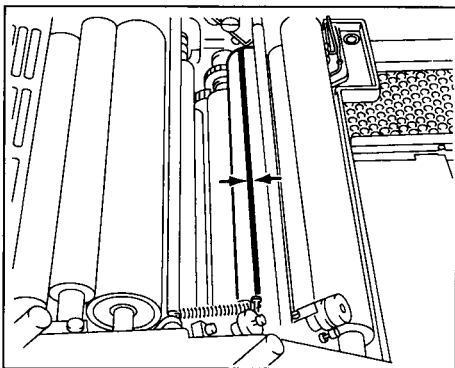

Crawl the metering roller and check the nip width on the metering roller.

<Adjustment procedures>

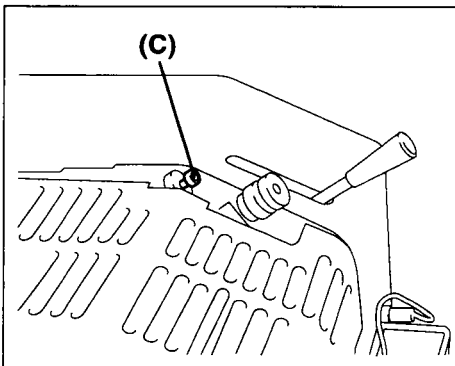

Turn the adjustment bolt (C) (operation side and non operation side) to adjust it.
When turning it in the “+” direction (in the counterclockwise direction), the pressure will be increased.

2. Checking the Plate Pressure and Impression Pressure

When the printing image becomes texture grained or white out occurs, the cause is poor printing pressure (plate pressure, impression pressure). Follow the procedures below.

	Standard nip width (mm) (inch)
Pressure between the blanket cylinder and plate cylinder (Plate pressure)	5.5 - 6.0 (0.22 - 0.24")
Pressure between the blanket cylinder and impression cylinder (Impression pressure)	6.5 - 7.0 (0.26 - 0.28")

(Note) The nip width given on the left is when using the RYOBI blanket and under blanket.

Checking procedures

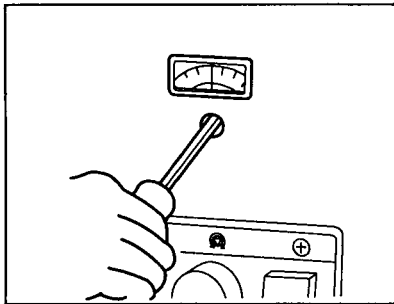

1. Align the plate pressure adjustment scale to the thickness of the plate.

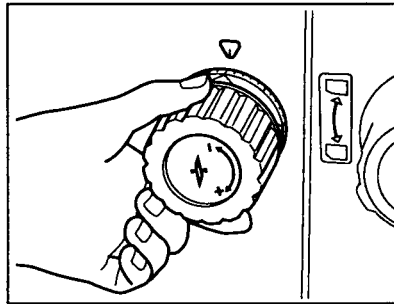

2. Align the impression pressure adjustment dial to the thickness of the paper.

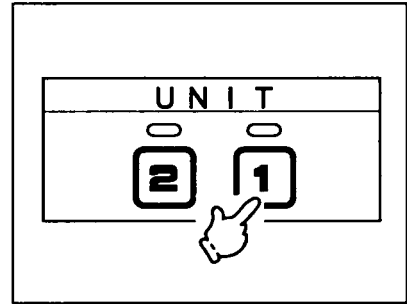

3. Push the unit selection button of the checking unit.

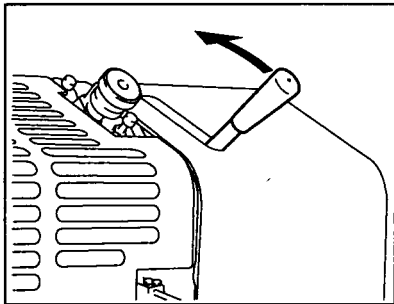

4. Shift the metering roller release lever in the direction of the arrow ( position) to release the metering roller from the water fountain roller.

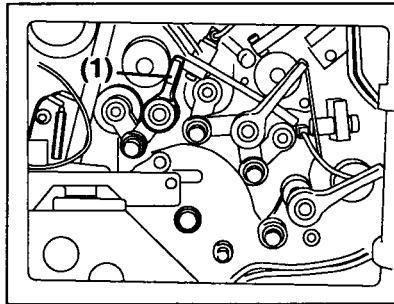

5. Set the water form roller release lever (1) at the  position.

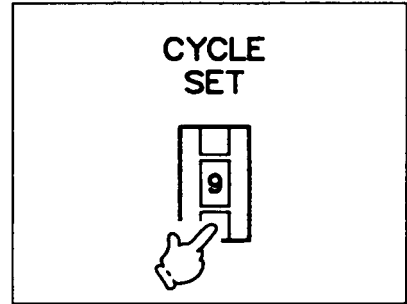

6. Set the cycle set button on the delivery section auxiliary switch panel to the cycle "9".
(Note) After completing the checking, return it to the cycle "0".

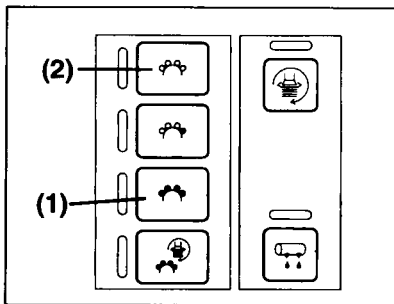

7. Run the machine and push the water and ink form roller ON button (1). After feeding ink to the plate surface fully, push the water and ink form roller OFF button (2) to release the water form roller and ink form roller from the plate surface.

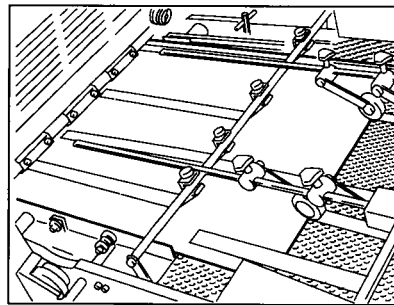

8. Feed a sheet of paper up to the front lay and stop the machine before doing the cylinder ON on the checking unit.

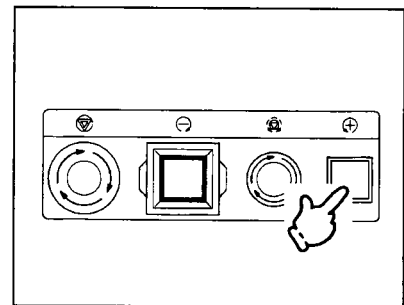

9. Push the forward crawl button repeatedly to transfer the ink to the paper.

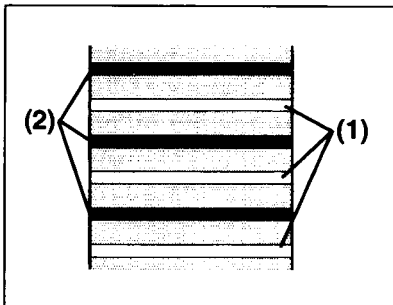

10. After transferring the ink to the paper, feed the paper to the delivery section.

Measure the nip width that appears on the paper.

(Reference)

The stripes on the printed sheet distinguish the impression pressure (1) from the plate pressure (2) as shown in the illustration.

3. Checking the Air Pump Nozzle Section



WARNING

Mount the cover removed in place after checking. Failure to follow this instruction may result in a serious injury.

When the wick tip in the air pump nozzle is not in the correct position, the proper amount of oil will not be supplied into the pump causing the pump to seize.

Checking procedures

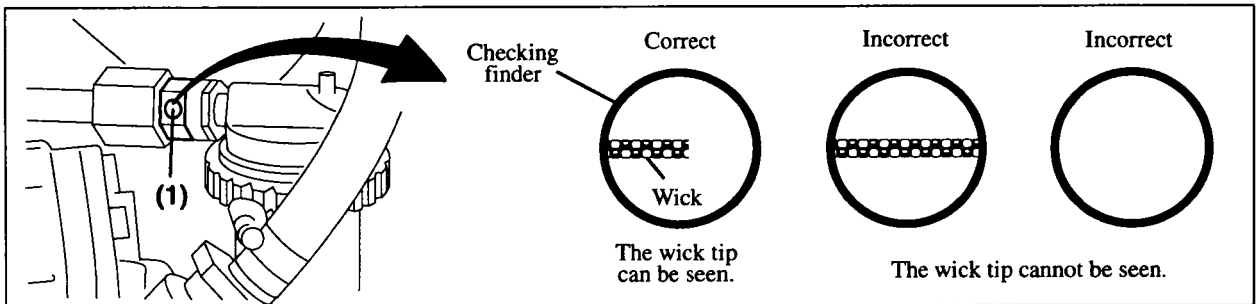

Check that the wick tip can be seen from the checking finder (1) once a month. If the wick tip cannot be seen, adjust the wick position.

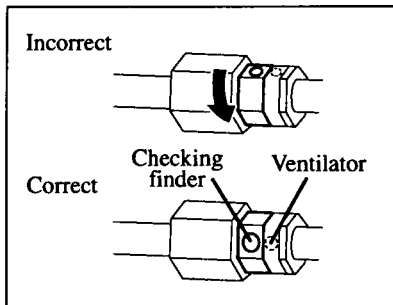

(Note) The checking finder position can be moved by rotating the nozzle. After checking the wick position, set the checking finder so that it is facing you. In this position, the dust cannot enter the ventilator easily.

(When moving the checking finder, the ventilator will move at the same time because the checking finder and ventilator are at the same position.)

Periodic Maintenance



WARNING

Turn off the power before doing the periodic maintenance. Failure to follow this instruction may result in a serious injury.

<< NOTICE >>

1. Do the periodic maintenance of each section to keep the machine in top operating condition and to assure high printing quality.
2. When not using the machine for a long time, apply rust preventive oil after cleaning each section of the machine with a cotton rag containing water and cleaning solution. If these instructions are not followed, rust and corrosion will form caused by the temperature, humidity, and chemicals.

1. Maintenance Item List

Do the maintenance of each section periodically by following the frequency given below as a guide. Although the maintenance frequencies shown below are considered, the maintenance frequency may have to be increased, depending on the machine operation.

No.	Item	Frequency
1	a. Supplying the oil to the centralized oiling system tank	When the oil level reaches the lower limit line.
	b. Supplying the oil to each section by using the centralized oiling system	Every day
	c. Manually oiling and greasing each section	Lubricate every day, every week, or every month by following the lubrication chart.
2	Cleaning the air pump filter	Every week
3	Cleaning the water fountain	
4	Cleaning each sensor surface	
5	Cleaning the skid rollers	
6	Cleaning the pull-out rollers and guide rollers	
7	Cleaning the powder spray device	
8	Cleaning the dampening solution circulation device filter	
9	Oiling the air pump	Every month
10	Cleaning the air pump nozzle filter	
11	Cleaning the static eliminator electrode	
12	Cleaning the PV pump of the dampening solution circulation device	
13	Cleaning the inside of the tank of the dampening solution circulation device	Every 6 months
14	Cleaning the filter of the powder spray device	

2. Maintenance Points

1) Lubrication

a. Supplying the oil to the centralized oiling system tank

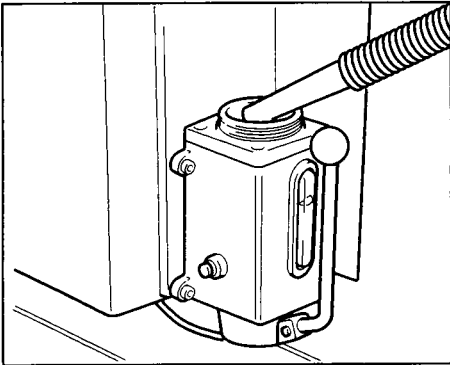

Before the oil level reaches the lower limit line, supply the oil through the filter.

b. Supplying the oil to each section by using the centralized oiling system

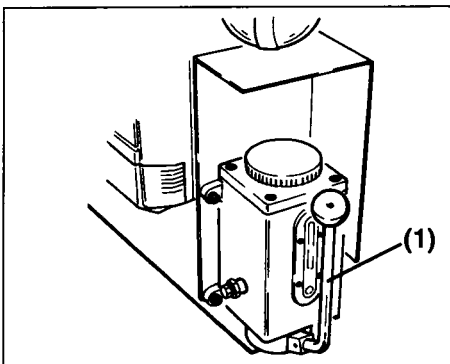

Before starting the machine, supply the oil to each section by using the centralized oiling system.

Pull the centralized oiling pump lever (1) and release it after 2 to 3 seconds to supply the oil. Repeat this 2 to 3 times.

[Recommended lubrication list for the centralized oiling system] and pump

<< NOTICE >>

1. Use the recommended oil. Do not use the used oil or oil with special additives.
2. The specific gravity and viscosity of the oil for the centralized oiling system and pump is lower than that of the manual lubrication oil. When this oil is used for the manual lubrication, the lubrication effect will be reduced prematurely. Therefore, only use this oil for the centralized oiling system and pump.

Maker	Oil
Shell	TETRA OIL 32 or 46
Mobil	Mobil DTE 24 or 25
ESSO	UNIPOWER MP 32 or 46

(Note) The recommended oil is equivalent to antiwear type ISO (International Organization for Standardization) VG 32 or 46.

c. Manually oiling and greasing each section



WARNING

1. Turn off the power before lubricating.
 2. Mount the cover removed in place after lubrication.
- Failure to follow these instructions may result in a serious injury.

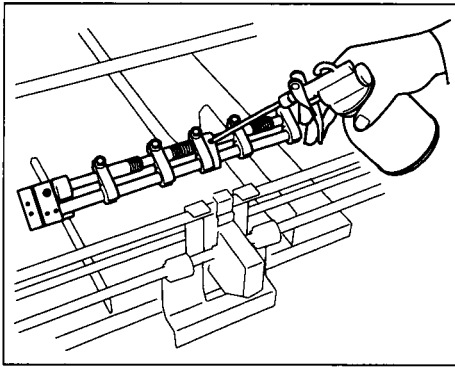

All of the required lubrication points are marked with red paint. Use oil or grease depending on the function of the part. Lubricate the machine following the lubrication chart that is included with the machine.

[Recommended lubrication list for the manual lubrication]

<< NOTICE >>

1. Use the recommended oil and grease. Do not use the used oil or oil with special additives.
2. The specific gravity and viscosity of the manual lubrication oil is higher than that of the oil for the centralized oiling system and pump. When this oil is used for the centralized oiling system and pump, the oil circulation may be poor and then this may cause the trouble with the centralized oiling system and pump.

Maker	Oil	Grease
Shell	GC OIL SE100	ALVANIA GREASE EP 1 ALVANIA GREASE 1
Mobil	Mobil DTE Oil Heavy	Mobilux EP 1
ESSO	SPARTAN EP 100 TERESSO 100	LITHTAN 1

- (Note) 1. The recommended oil is equivalent to antiwear type ISO (International Organization for Standardization) VG 100.
2. The recommended grease is equivalent to the multipurpose grease (Li) NLGI No. 1.
3. Supply oil and grease at all the lubricating points every week for 3 months after installation. After that, lubricate the machine following the lubrication chart.

2) Cleaning the air pump filter



WARNING

Mount the cover removed in place after cleaning. Failure to follow this instruction may result in a serious injury.

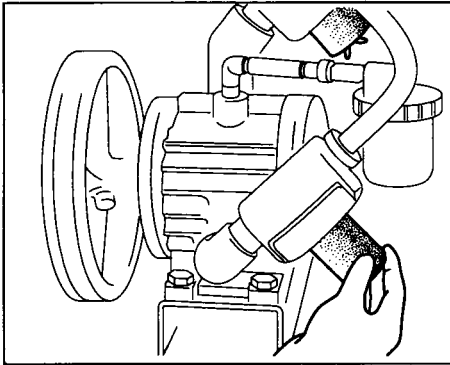

If the pump filter is dirty, the vacuum force of the pump will be lowered. Take out the filter and remove any dirt and foreign particles on the filter, and dip it in cleaning solution periodically.

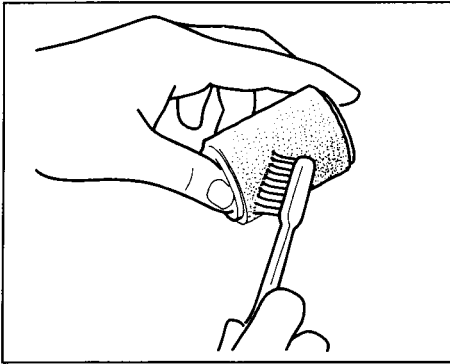

3) Cleaning the water fountain

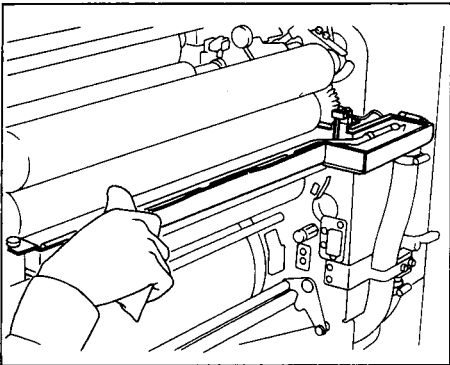

Foreign particles will accumulate in the water fountain. Remove any foreign particles in the water fountain.

4) Cleaning each sensor surface



WARNING

Push the emergency stop button to stop the machine before cleaning. Failure to follow this instruction may result in a serious injury.

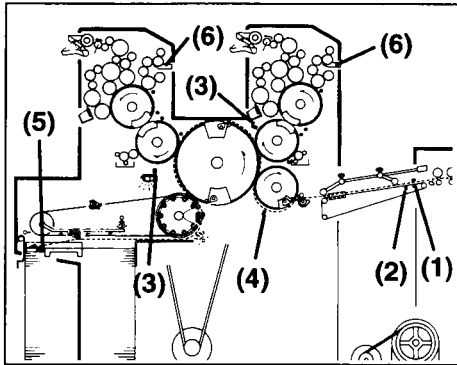

Each sensor is positioned as shown in the illustration.

- (1) Double sheet detector sensor
- (2) Paper feed sensor
- (3) Blanket jam detector sensor
- (4) Cylinder ON sensor
- (5) Delivery pile lowering sensor
- (6) Water sensor

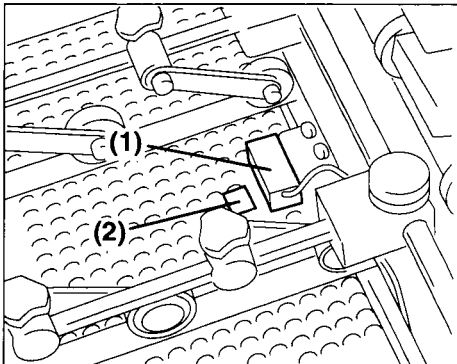

<< NOTICE >>

If using cleaning solution when cleaning the sensor surface, it will damage the sensor. Only use a dry soft rag when cleaning.

Foreign particles and spray powder adhering on the sensor surface (1) through (5) will cause malfunctioning. Wipe off the sensor surface with a dry soft rag and keep it clean.

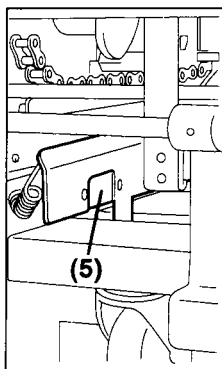
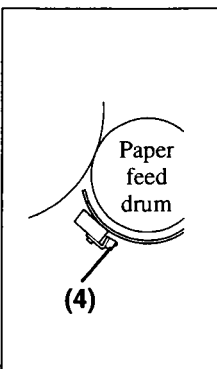
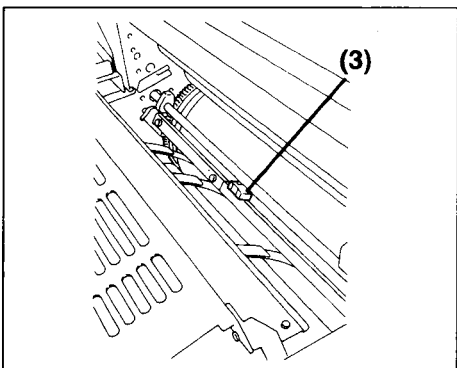

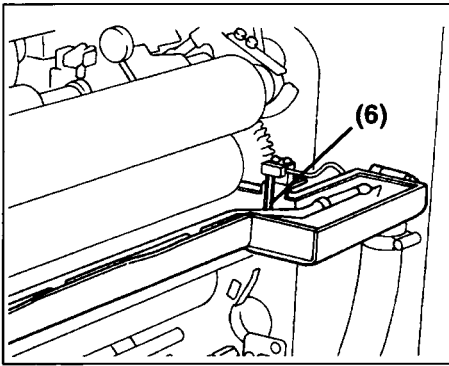

Foreign particles and ink adhering on the water sensor (6) electrode causes malfunctioning. Wipe off the electrode with a dry soft rag and keep it clean.

When it becomes too dirty, clean it with a rag containing water and cleaning solution. At this time, be careful not to allow the cleaning solution to enter the sensor body.

5) Cleaning the skid rollers

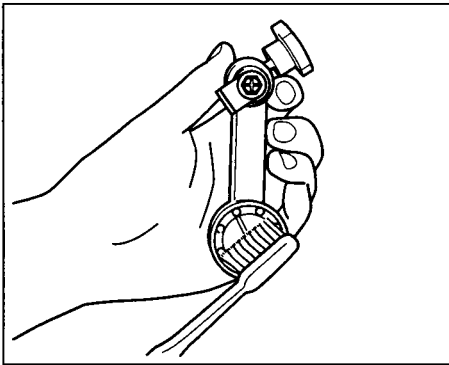

When the skid rollers do not rotate smoothly because dust or foreign particles are adhered on the bearing, clean the bearing using a brush containing cleaning solution. After cleaning it, lubricate it with a little oil.

(Note) Wipe off any excess oil that adheres on the bearing when supplying too much.

6) Cleaning the pull-out rollers and guide rollers

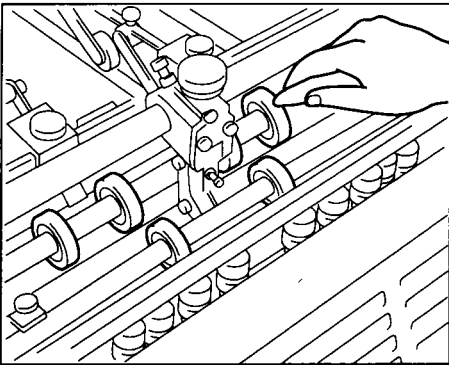

If ink adheres on the pull-out rollers and guide rollers, the roller surface will become hard. Clean them after checking the surfaces of the rollers.

7) Cleaning the powder spray device

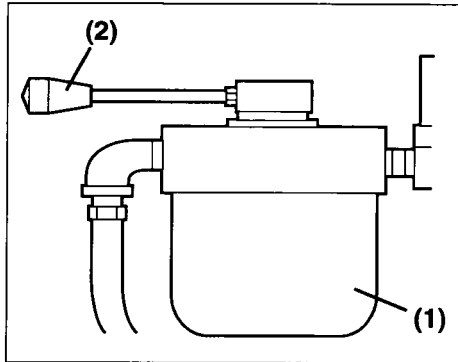

After using the powder spray device, and then not using it for a long time, the spray powder will harden in the spray hose. After using the powder spray device, remove the powder bottle (1), set the spray volume control lever (2) at the "0" position, and feed waste paper to use up any spray powder remaining in the hose.

- (Note) 1. When the spray powder in the bottle gets dirty or foreign particles are mixed in, empty and dispose of the spray powder in the bottle. Clean the inside of the bottle with a clean dry soft rag.
2. Do not use spray powder which has hardened because it contains moisture.

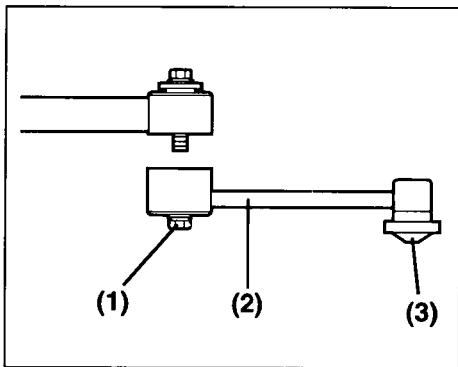

When the spray powder blocks the spray nozzle, loosen the nut (1), remove the nozzle (2), and clean the nozzle (2) and nozzle tip (3).

(Note) When removing the nut (1), be careful not to drop the washers.

8) Cleaning the dampening solution circulation device filter

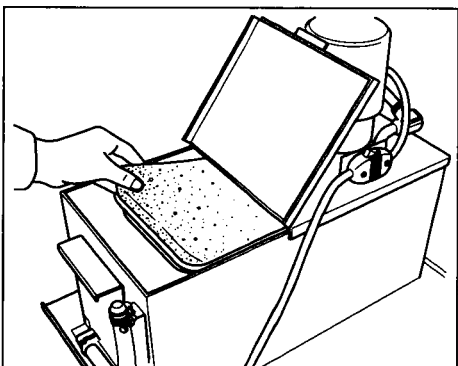

The foreign particles will accumulate in the dampening solution circulation device filter.

If the filter is blocked, the circulation function will be reduced. Remove the filter and wash it with water.

9) Oiling the air pump



WARNING

Mount the cover removed in place after oiling. Failure to follow this instruction may result in a serious injury.

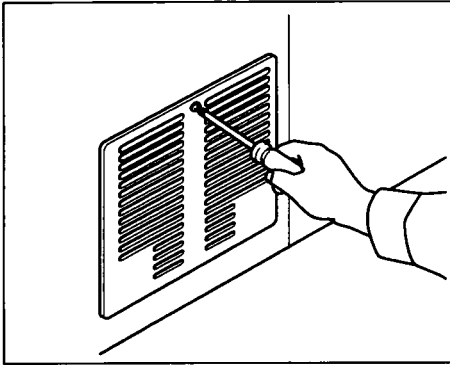

The air pump is inside the door at the feeder section.

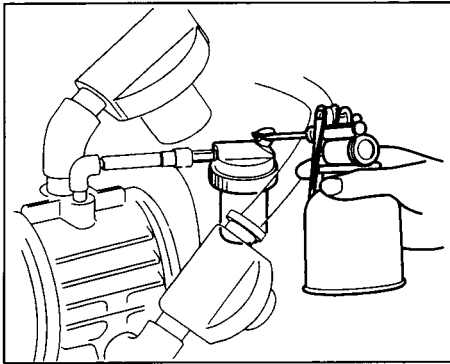

Check the oil level once a week and be sure that the oil in the oil cup is always full.

[Recommended lubrication list for the pump and centralized oiling]
system

<< NOTICE >>

1. Use the recommended oil. Do not use the used oil or oil with special additives.
2. The specific gravity and viscosity of the oil for the pump and centralized oiling system is lower than that of the manual lubrication oil. When this oil is used for the manual lubrication, the lubrication effect will be reduced prematurely. Therefore, only use this oil for the pump and centralized oiling system.

Maker	Oil
Shell	TETRA OIL 32 or 46
Mobil	Mobil DTE 24 or 25
ESSO	UNIPOWER MP 32 or 46

(Note) The recommended oil is equivalent to antiwear type ISO (International Organization for Standardization) VG 32 or 46.

10) Cleaning the air pump nozzle filter

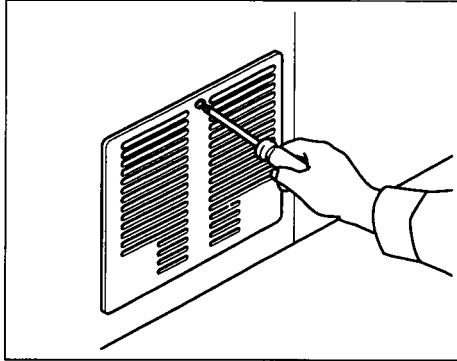

The air pump is inside the door at the feeder section.

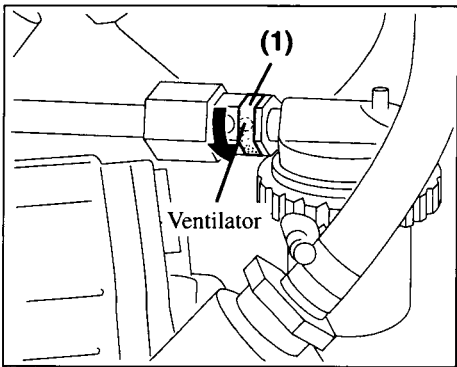

If the air pump nozzle ventilator filter (1) is blocked, oil may not be supplied into the pump and the pump may seize. Check the ventilator filter and when it is dirty or blocked, remove the dust in the filter by using a vacuum cleaner, or rotate the filter and set a part that is not dirty.

11) Cleaning the static eliminator electrode



CAUTION

Turn off the power before cleaning. Failure to follow this instruction may result in an electric shock.

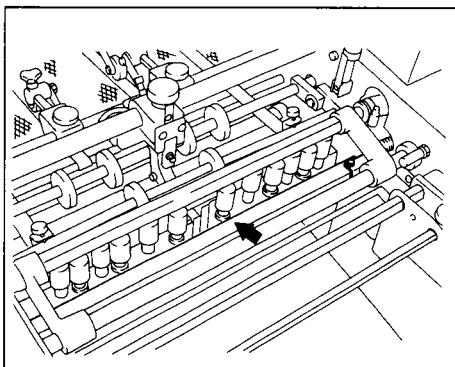

Feeder side

When the static eliminator is used for a long time, carbon will build up and adhere on the electrode. This causes the eliminating force to become weak. Clean the electrode with the brush periodically.

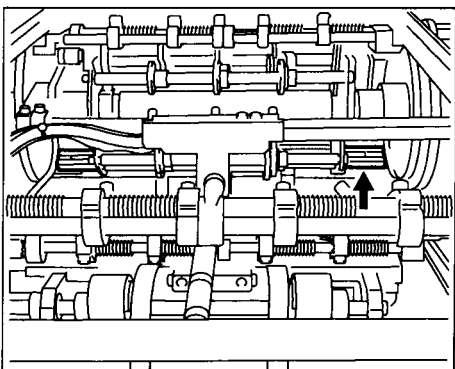

Delivery side

12) Cleaning the PV pump of the dampening solution circulation device

The returning dampening solution from the water fountain will be sucked into the dampening solution circulation device by the impeller in the bottom of the PV pump. When foreign particles adhere in the bottom of the PV pump, the suction force will be reduced. So please remove any foreign particles inside periodically.

Cleaning procedures

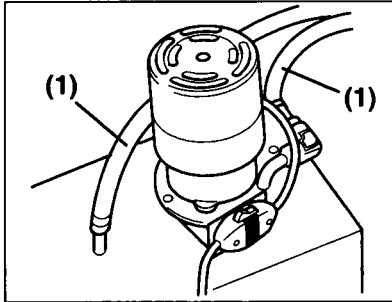

1. Remove the 2 hoses (1) that are connected to the PV pump.

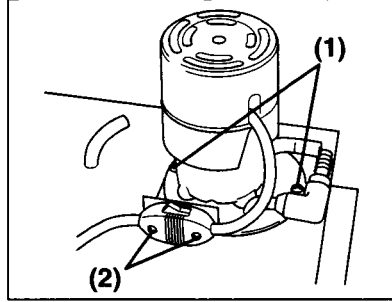

2. Loosen the 4 bolts (1) and (2).

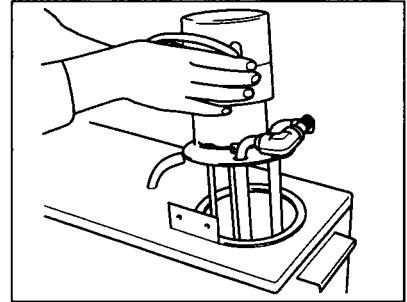

3. Take the PV pump out.

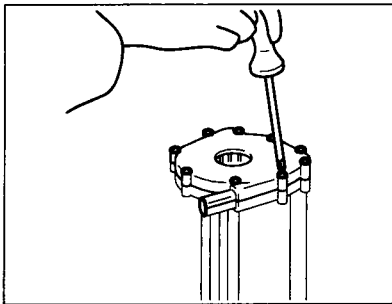

4. Loosen the screws and remove the cover.

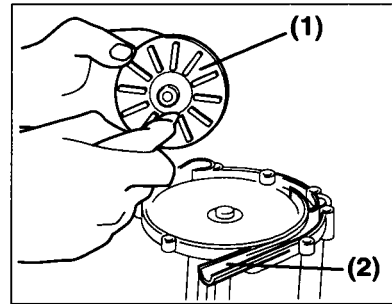

5. Clean the impeller (1) and groove section (2).

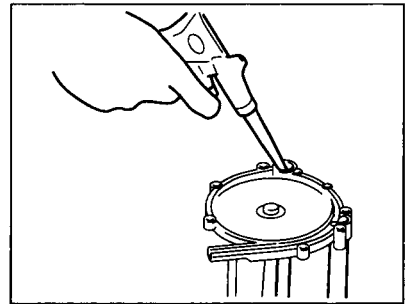

6. Blow the air in to clean the inside of the pipe.

13) Cleaning the inside of the tank of the dampening solution circulation device

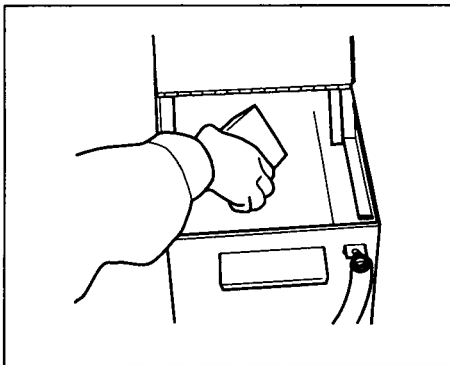

Foreign particles and spray powder will accumulate on the bottom of the tank. Drain the dampening solution in the tank from the water level control cup and clean the tank with a soft sponge.

14) Cleaning the filter of the powder spray device

**WARNING**

Mount the cover removed in place after cleaning. Failure to follow this instruction may result in a serious injury.

The spray pump is inside the lower cover on the non operation side. If the pump filter is dirty, the vacuum force of the pump will be lowered. Clean the filter periodically.

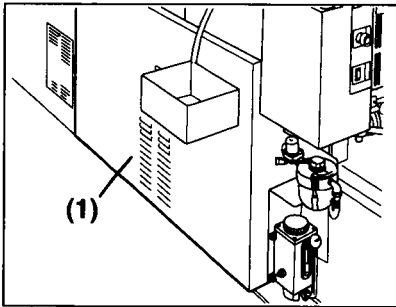
Cleaning procedures

1. Remove the cover (1).

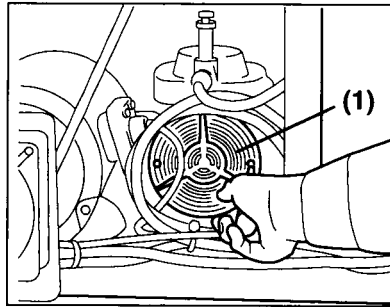

2. Loosen the 2 screws and remove the cover (1).

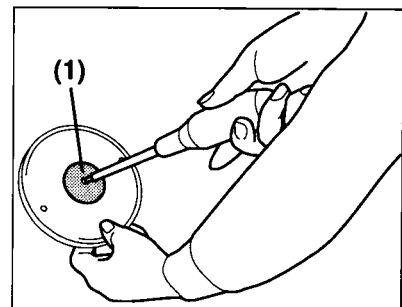

3. Loosen the screw and remove the net cover (1).

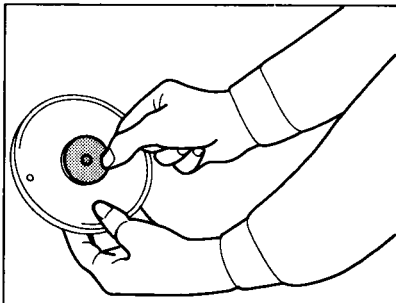

4. Take out the filter, remove foreign particles on the filter, and dip it in cleaning solution.

Replacing the Supplies

1. Replacing the Blanket

After the blanket is used for a long time, the rubber will age causing the adhesiveness to be increased and the surface of the blanket to become slick and shiny. As a result, paper may adhere on the blanket surface, causing such picking trouble as peeling and roughness on the paper to occur. If this problem becomes worse, paper may be jammed on the blanket cylinder or ink may not be transferred smoothly onto the blanket resulting in poor printing. When this happens, replace the blanket with a new one.

(Note) The blanket jam detector may actuate incorrectly depending on the blanket color. For more detailed information, please ask your service technician.

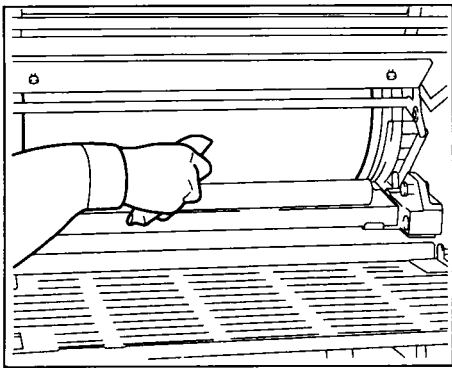

<< NOTICE >>

1. Before mounting the blanket, remove stains, etching solution, and water on the blanket cylinder surface. Make sure that the cylinder is completely dry, and then apply rust preventive oil over the entire surface of the blanket cylinder to protect it.
2. Be careful that the blanket recovery solution and other chemicals do not adhere on the blanket cylinder surface. If they adhere on the blanket cylinder surface, wipe them off with a cotton rag containing water and cleaning solution immediately and apply rust preventive oil over the entire surface of the blanket cylinder to protect it.
(Please refer to the recommended rust preventive oil list shown on the page 117.)
3. Mount the aluminum bars (both the leading and tail edges) in the clamp holders exactly. If it is not mounted properly, when running the machine, the aluminum bars may release from the holders and the blanket cylinder will be damaged.

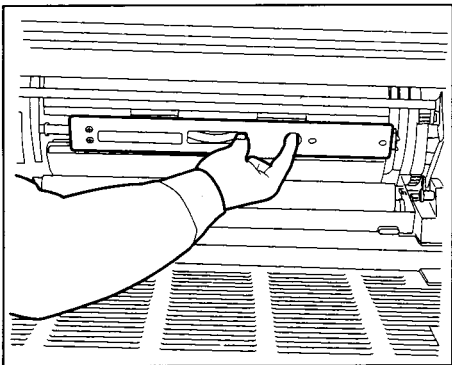

WARNING

Mount the blanket cylinder gap safety cover, after mounting the blanket. Failure to follow this instruction may result in a serious injury.

When removing the blanket, reverse the mounting procedures.

Mounting procedures

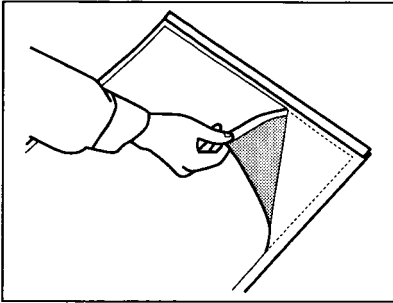

1. Attach the under blanket on the back of the blanket.
As the mounting position is indicated on the back of the blanket, fix the under blanket on that position using the double sided tape that comes with the under blanket.

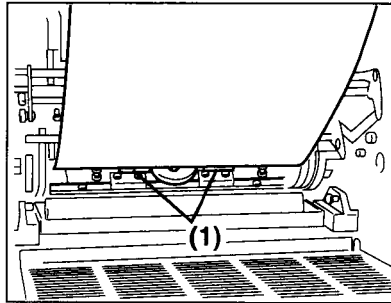

2. Loosen the tension knob and mount the blanket leading edge on the blanket cylinder clamp holder (1) on the leading edge. (Reference)
The fixing side of the blanket and under blanket with tape is the leading edge.

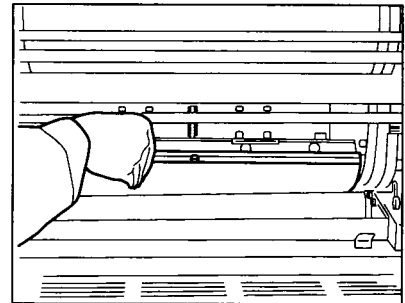

3. Continuously pushing the forward crawl button, while pulling the blanket and under blanket to fit it on the blanket cylinder.

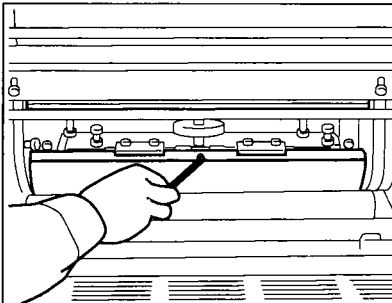

4. Mount the blanket tail edge in the blanket cylinder clamp holder on the tail edge by using the 4 mm (0.16") Allen wrench.

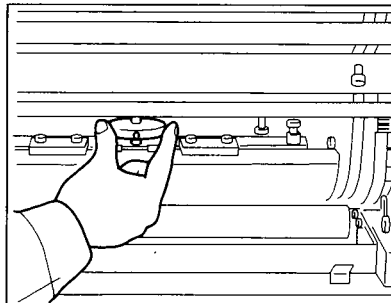

5. Turn the tension knob to tension the blanket.

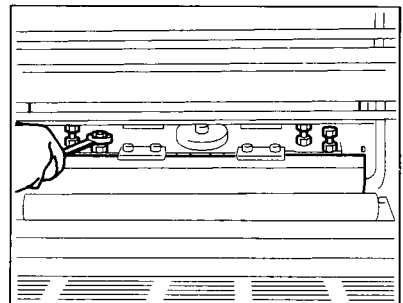

6. Tighten the blanket tension bolts (leading and tail edges).
Feed about the 10 sheets of paper to fit the blanket to the cylinder and then tension the blanket again. Repeat this procedure 2 or 3 times.

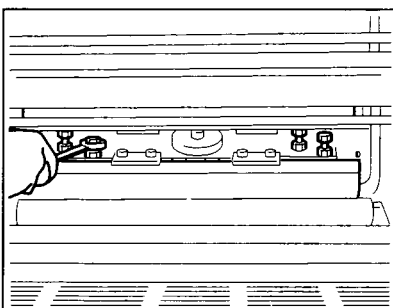

7. Finally turn the blanket tension bolt the 1/4 to 1/2 turn further for the final tensioning.

2. Replacing the Sheet Separator



CAUTION

Stop the machine before replacing. Failure to follow this instruction may result in an injury.

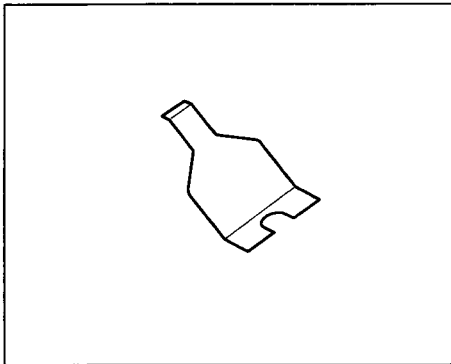

When the edge of the sheet separator is bent, replace it with a new one.

1) Removing

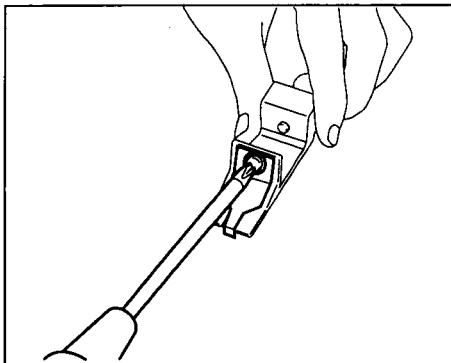

Loosen the screw and remove the sheet separator.

2) Mounting

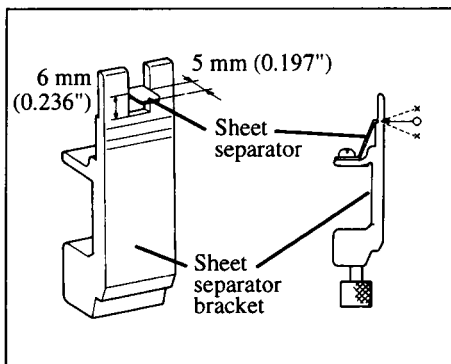

Mount the new sheet separator and set the separator so that it is positioned 5 mm (0.197") out from the front surface of the sheet separator bracket and is 6 mm (0.236") above from the bottom of the notch in the sheet separator bracket.

(Reference) The standard line for positioning the sheet separator is marked on the sheet separator bracket. So when mounting the sheet separator, aligning it with this line assures that it is mounted at the standard position.

Align the height of the sheet separator to these.

Align with the bent part of the sheet separator.

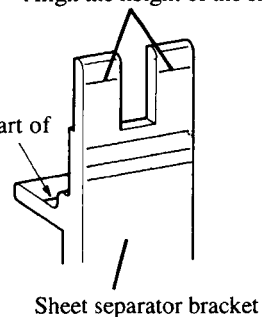

3. Replacing the Water Form Roller and Metering Roller

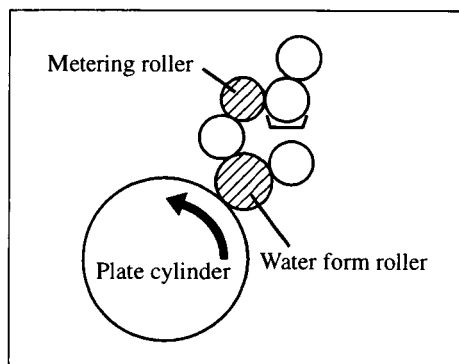

Generally the rubber roller shrinks over time and the diameter becomes smaller.

Especially, if using isopropyl alcohol, the shrinking will be intensified and the hardness will be increased 20 to 30 % a year. As the hardness increases, the characteristics of the roller are lost and the dampening solution supply balance will become unstable. This will result in stains being caused and excessive emulsification occurring.

The life of the rubber roller is usually from 6 months to one year after starting initial printing on the machine. After this period has passed, replace the roller. For more details, please ask your service technician.

- (Note)
1. The replacement period of the roller will differ depending on the machine using condition.
 2. When doing printing with large solids or when requiring high printing quality, the replacement period of the roller will be quicker.

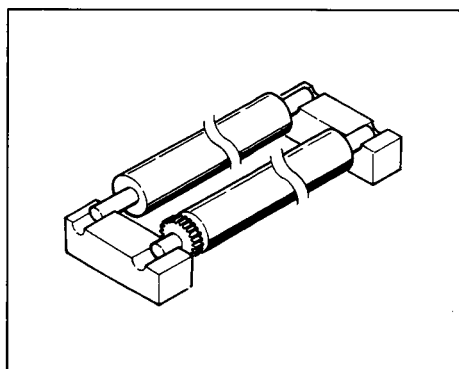



(Reference) When keeping an extra roller for replacement, if the roller is not properly stored, the roller may be damaged. So please store it following the points below.

1. Do not put the roller surface directly on the floor. It should be held by the shaft section. (See illustration.)
2. Store the roller in a cool [below 20°C (68°F)] dark (no light) place.

1) Mounting the water form roller

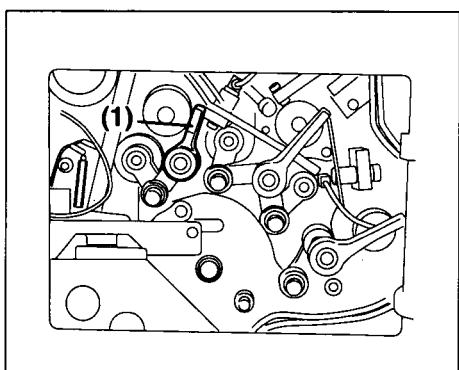
(Note) Remove the water rider oscillating roller before mounting or removing the water form roller.



Mount the water form roller after setting the water form roller release lever (1) at the  position. After mounting it, set the lever at the  position.

« NOTICE »

The side of the shaft with the gear on is the operation side. If reversing the water form roller mounting direction, the machine may be damaged.

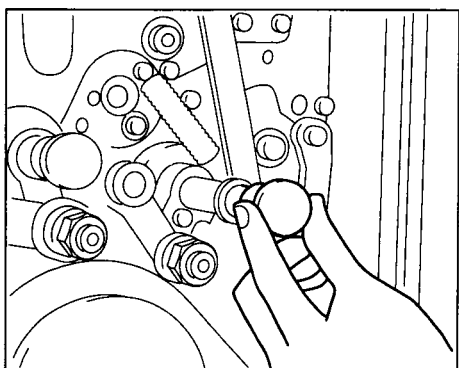

Align the water form roller shaft notch with the stopper and push the roller in fully and then turn it slowly until there is a response until the roller cannot be turned anymore.

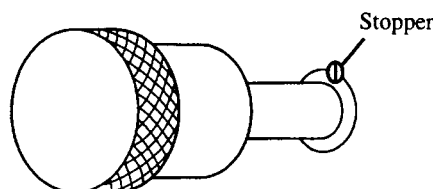

4. Replacing the Water Control Wiper



CAUTION

Stop the machine before setting. Failure to follow this instruction may result in an injury.

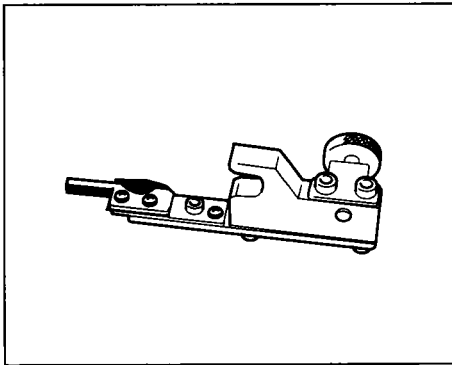

When the water control wiper wears out, the printing quality may not be stable due to the over supply of dampening solution. Replace it with a new one.

1) Mounting

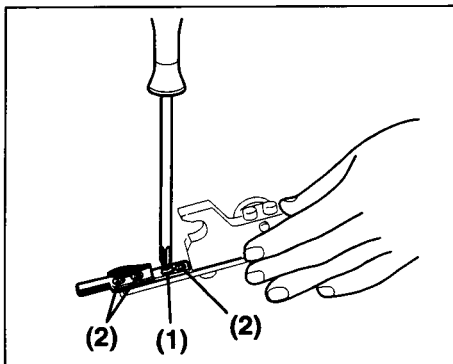

Fix the water control wiper on the bracket by using the fixing screw (1).

<< NOTICE >>

Never loosen the water control wiper fixing screws (2). If loosening them, the stable pressure cannot be assured.

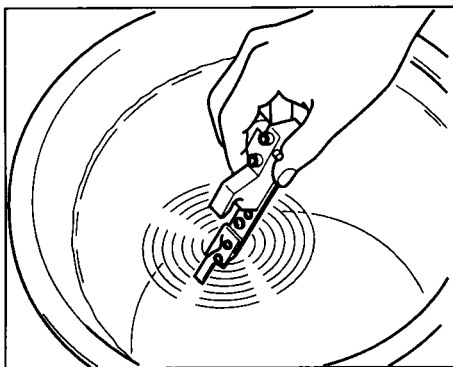

<< NOTICE >>

Soak the water control wiper in water before mounting it on the machine. Mount the wet water control wiper on the machine and run the machine. By doing this, stable printing quality is assured immediately after mounting it.

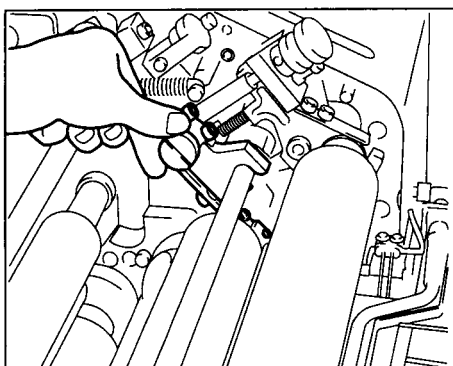

Mount the water control wiper on the machine.

Troubles and Countermeasures

5-1 Error Message

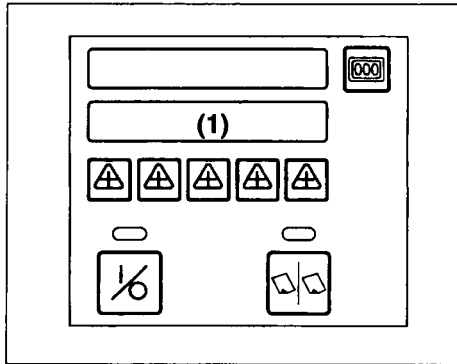

When having input trouble on the machine, a program in the machine will indicate an error message.

If any one of the error messages (E-0, E-1, E-2, E-3, and E-5) is indicated on the set counter indication (1) on the delivery section operation panel, please contact your service technician and tell him the error message.

5-2 Other Troubles

When the troubles listed below occur during the printing, first follow the countermeasures given below and if the trouble is not corrected then call your service technician for after sales service.

1) The printing image becomes texture grained or white out.

Cause

Countermeasure

Improper plate pressure and impression pressure
(Checking procedures : P. 130)



1. Check the plate and blanket packing thickness. (P. 39)
2. Check the plate pressure adjustment scale and impression pressure adjustment dial setting. (P. 71, 88)
3. Replace the blanket. (P. 144)
(When the blanket is partially smashed.)

Improper ink roller pressure



Adjust the ink roller pressure. (P. 119)

Poor ink transfer because of high ink tack



Add reducer into the ink to lower the tack.

Excess emulsification of the ink



1. Check the supply volume of the dampening solution.
2. Clean the ink rollers. (When there is excessive ink emulsification on the rollers, it is hard to control. Clean the rollers.)

2) Doubling of the image on the printed sheet

Cause	Countermeasure
Poor blanket tension	⇒ Correctly tension the blanket. (P. 145)
The blanket is smashed. (One part is concave.)	⇒ Replace the blanket with a new one. (P. 144)
The plate floats up from the plate cylinder.	⇒ Retension the plate. (P. 70)
The plate pressure and impression pressure are too strong.	⇒ <ol style="list-style-type: none"> 1. Check the plate pressure adjustment scale and impression pressure adjustment dial setting. (P. 71, 88) 2. Check the plate and blanket packing thickness. (P. 39)
The paper is not fed straight.	⇒ Check the setting of the feeder board. (P. 78)
The paper condition is poor and is partially wavy.	⇒ <ol style="list-style-type: none"> 1. Season the paper to correct it to be flat. 2. Fix the paper curl. (P. 105)
The paper is not released from the blanket smoothly because the ink tack is too high and then the tail edge of the sheet moves too much.	⇒ Add reducer into the ink to lower the tack.
The paper slips off from the impression cylinder grippers.	⇒ Clean the grippers and gripper bases on the impression cylinder.

3) Successive color ink is not printed on the paper well. (Poor trapping)

Cause	Countermeasure
The successive color ink tack is too high.	⇒ Add reducer into the ink to lower the tack.

4) The color is muddy.

Cause	Countermeasure
The successive color ink tack is too high.	⇒ Add reducer into the ink to lower the tack.

5) The paper is not fed smoothly.

Cause

Countermeasure

A lack of vacuum or blower volume	⇒	<ol style="list-style-type: none"> 1. Control the vacuum volume and blower volume. (P. 75) 2. Clean the air pump filter. (P. 136)
Poor rotation of the skid rollers	⇒	Clean and lubricate the skid rollers. (P. 138)
Electrostatic is generated on the paper.	⇒	<ol style="list-style-type: none"> 1. Clean the static eliminator electrode. (P. 141) 2. Adjust the humidity in the working area. (The normal humidity should be around 60%.)

6) Poor registration
(Poor front registration)

Cause

Countermeasure

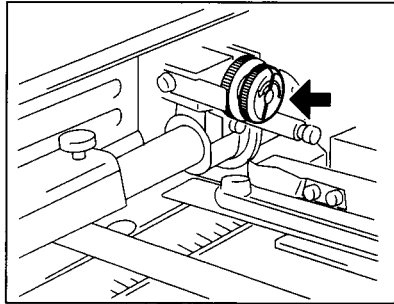
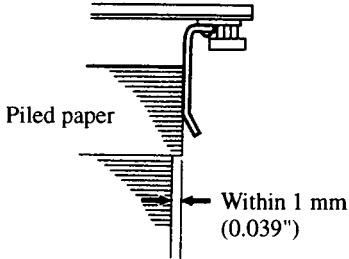
Poor positioning of skid rollers	⇒	Reposition the skid rollers. (P. 83)
Poor paper feed volume	⇒	<p>Adjust the rotation volume of the upper feed roller. (1-1/4 to 1-1/2 rotations).</p> 
The distance between the skid rollers and paper tail edge is not always the same due to poor paper cutting.	⇒	<p>Cut the paper again so that difference of the paper size is within 1 mm (0.039").</p> 

The leading edge does not contact the stop finger exactly due to poor paper cutting. ⇒ Cut the paper again.

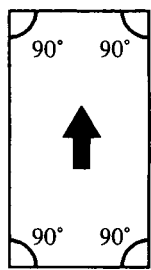

The paper is curled. ⇒
1. Season the paper to correct it to be flat.
2. Fix the paper curl. (P. 105)

(Poor lateral registration)

Cause

Countermeasure

The push side guide and spring is too strong. ⇒ Set the push side guide and spring.

The paper feed position is poor and the side edge of the paper contacts the stop finger. ⇒ Move the paper feed position laterally and set so that it does not contact the stop finger.

The side edge of the paper does not contact the push side guide exactly due to poor paper cutting. ⇒ Cut the paper again.

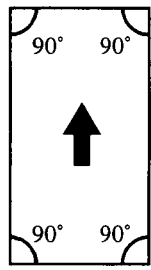

The paper is curled. ⇒
1. Season the paper to correct it to be flat.
2. Fix the paper curl. (P. 105)

7) The paper is bent.**Cause**

Poor positioning of the sheet separators

**Countermeasure**

Reposition the sheet separators. (P. 73)

The paper is not fed smoothly to the retainers from the pull-out rollers. (The paper is bent upward.)



Reposition the retainers. (P. 82)

8) The paper is wrinkled.**Cause**

The paper has waves.

**Countermeasure**

1. Season the paper to correct it to be flat.
2. Fix the paper curl. (P. 105)

The impression pressure is too strong.



1. Check the impression pressure adjustment dial setting. (P. 88)
2. Check the blanket packing thickness. (P. 39)

9) Poor roller cleaning.**Cause**

The cleaning solution dries too fast.

**Countermeasure**

Use a cleaning solution that is slow drying.

Poor blade pressure on the ink roller cleanup attachment



Ask your service technician how to adjust it.

10) The dampening solution feed is not stable.

Cause	Countermeasure
The density of the alcohol substitute and etching solution is not the standard value.	Make the dampening solution following the maker's recommended density.
Poor water roller maintenance	Do the water roller maintenance to assure the hydrophilic property. (P. 115)
The metering roller shape has deformed and worn out.	The roller has to be replaced depending on the condition of the aqua film between the metering roller and water fountain roller. Ask your service technician.
Wearing out of the water control wiper	Replace the water control wiper. (P. 148)
Improper water roller pressure	Adjust the water roller pressure. (P. 123)

Optional Accessories Edition

This edition explains about 3 optional accessories; the Dampening Solution Cooling/Circulation Device, PCS-F, and Blanket Cleaning Device.

Dampening Solution Cooling/Circulation Device

1-1 Outline

For this device, the dampening solution on the first unit and second unit is kept the constant temperature and circulates to keep the printing quality stable.

1-2 Name and Function of Each Part

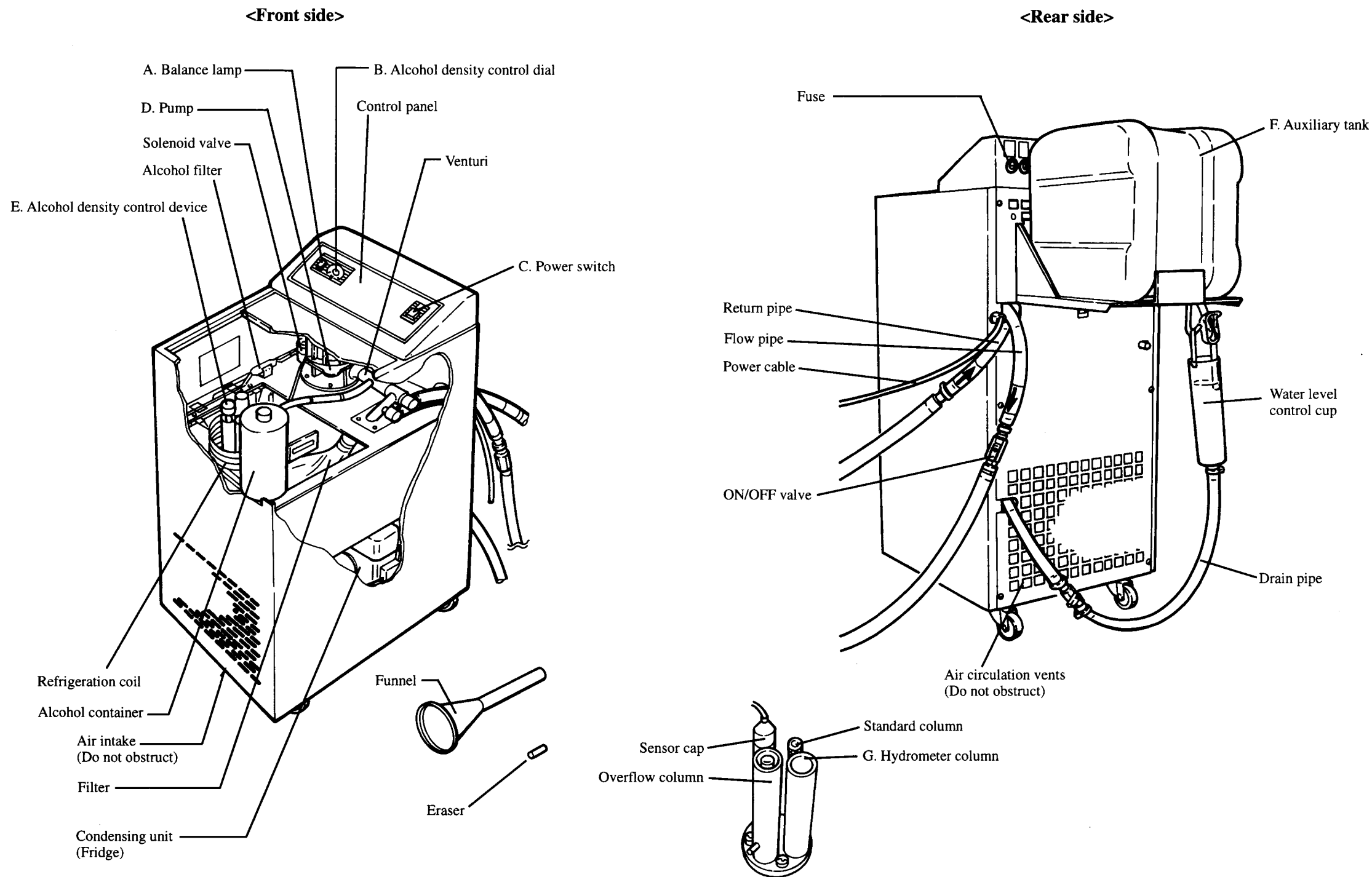

This device uses isopropyl alcohol.

WARNING
EXTREMELY FLAMMABLE
VAPORS CAN EXPLODE
HARMFUL OR FATAL IF SWALLOWED
 If swallowed, do not induce vomiting, call a physician immediately.
 Keep out of reach of children.
 Avoid prolonged breathing of vapors.
 Do not siphon by mouth.
 Do not store in vehicle or living space.
 Store and use in well-ventilated area.
 Vapors can be ignited by a spark or flame source many feet away.
 Keep away from flame, pilot lights, stoves, heaters, electric motors, and other sources of ignition.
 Keep container closed.

A. Balance lamp

When the alcohol density is stable at the value set using the alcohol density control dial, the lamp will light.
 When the alcohol density decreases, the lamp will go off, and the alcohol will be supplied.

B. Alcohol density control dial

This is used to control the alcohol density.

C. Power switch

When the power switch is at the position, the pump and cooling system will operate.

D. Pump

This is the pump that circulates the dampening solution from the device to the base machine and back.

E. Alcohol density control device

This is the alcohol density automatic control device used to change the surface tension of the dampening solution by changing the alcohol density.

F. Auxiliary tank

The dampening solution supplement is held in this.

G. Hydrometer column

When checking the alcohol density, put the alcohol hydrometer in this.

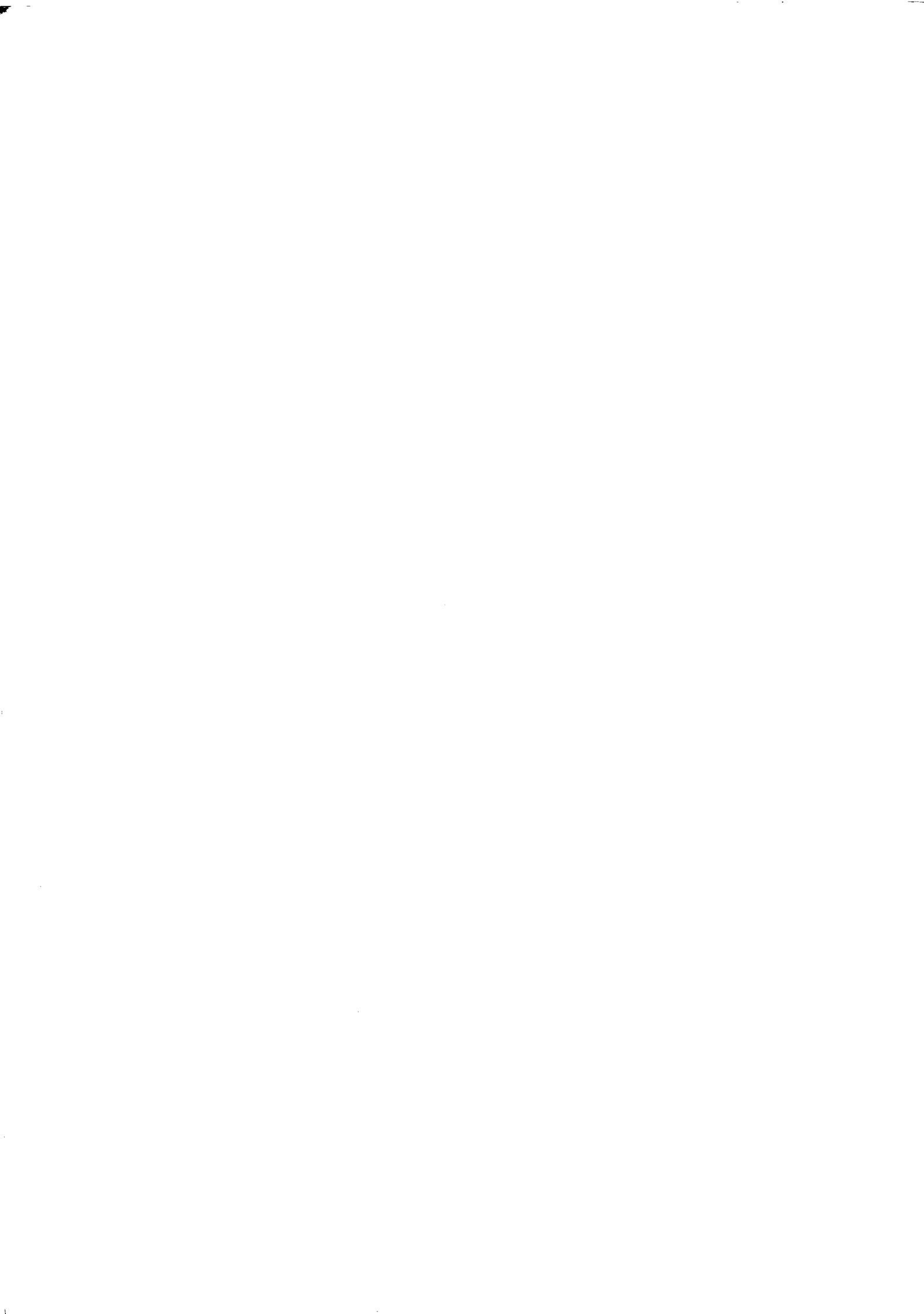

1-3 Operation Procedures

1) Prepare the dampening solution.

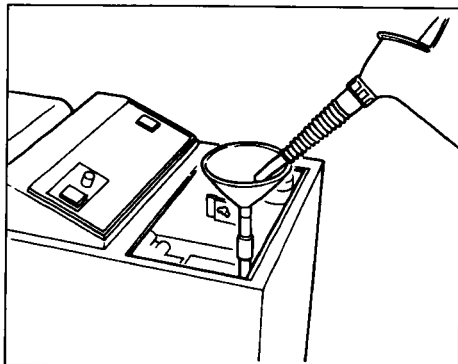

Mix the alcohol in the dampening solution in advance, and put it in the tank.

For the proper density of alcohol, please ask your service technician when installing the machine.

(Reference) To keep the proper dampening solution level, 15 liters of dampening solution should be prepared.

2) Set the alcohol density.

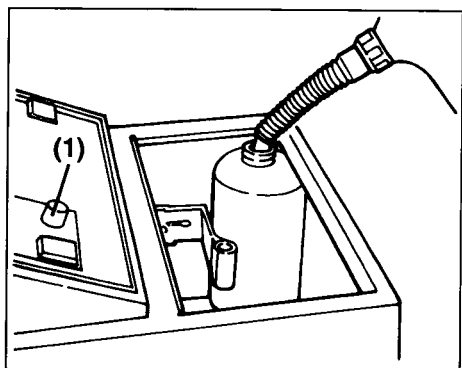

Remove the cap of the alcohol container and put the alcohol in it.

(Note) When the alcohol is used up, bubbles will appear in the tank easily.

When the alcohol is used up, immediately set the alcohol density control dial (1) to "0" and supply the alcohol in the alcohol container.

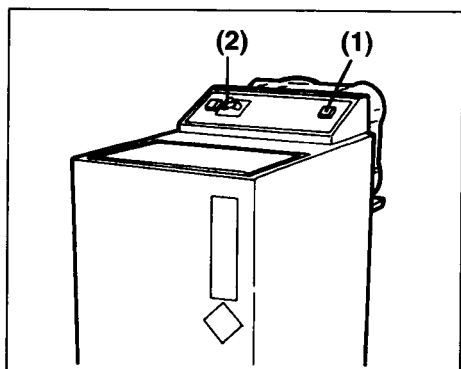

Set the power switch (1) at the ON position.

After running the device for from 15 minutes to 30 minutes and the dampening solution is properly mixed and cooled, set the alcohol density control dial (2) at the required density.

For the required density, please ask your service technician when installing the machine.

3) Check the alcohol density.

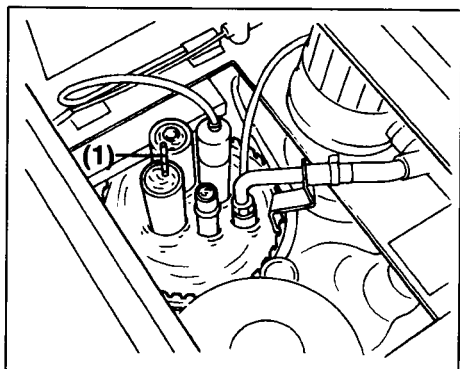

Put the hydrometer (1) in the hydrometer column, then check the alcohol density.

4) Set the auxiliary tank.

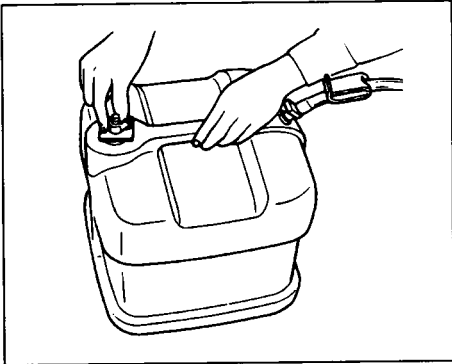

Put the dampening solution in the auxiliary tank and tighten the cock tightly. There is no need to add alcohol in.
(Reference) The auxiliary tank has a capacity of 15 liters.

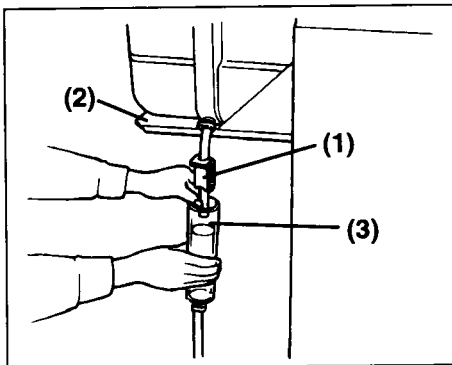

Fix the hose by using the clip (1) and put the auxiliary tank on the supporting table (2).
Check that the hose is properly positioned in the water level control cup (3) and after opening the ON/OFF valve of the drain pipe fully, release the clip (1).

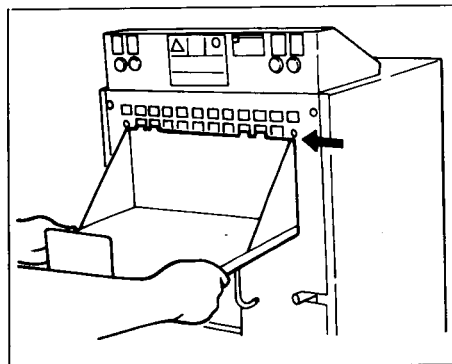

(Reference) When setting the supporting table of the auxiliary tank, set it at the position shown by the arrow on the base device rear side.

1-4 Maintenance

1) Cleaning the water fountain (Every week)

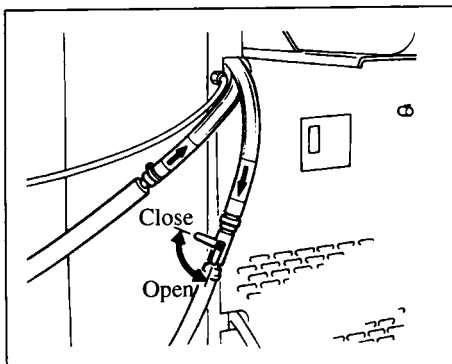

Close the ON/OFF valve on the dampening solution cooling/circulation device to drain the dampening solution in the water fountain.
After the cleaning, be sure to open the ON/OFF valve.

2) Cleaning the inside of the tank of the dampening solution cooling/circulation device (Every week)

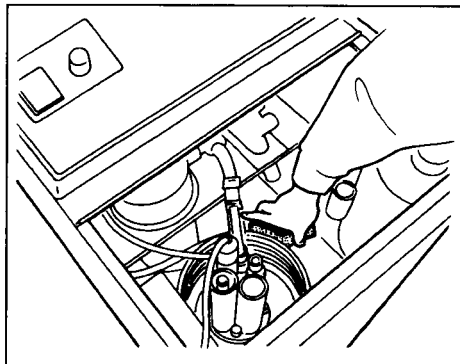

Foreign particles and spray powder will accumulate on the bottom of the tank. Drain the dampening solution in the tank from the water level control cup and clean the tank with a soft sponge.

3) Cleaning the tower of the dampening solution cooling/circulation device (Every week)

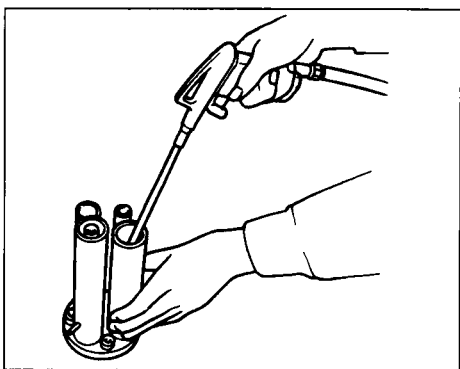

Foreign particles will accumulate inside of the tower. Blow the air in to clean the inside of the tower.

4) Cleaning the needle of the dampening solution cooling/circulation device (Every week)

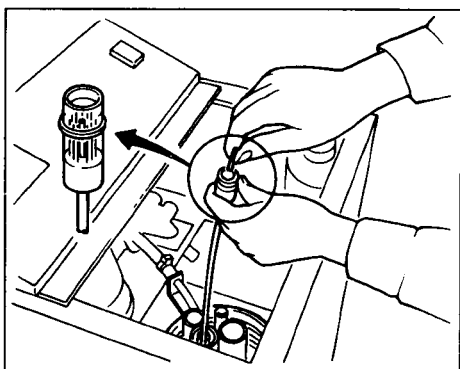

Remove any stains that adhere on the needle surface by using an eraser. Press the eraser on the needle and twist it 2 to 3 times. Just doing this can clean the needle surface. After the cleaning, mount it at the former position properly.

5) Replacing the filter of the dampening solution cooling/circulation device

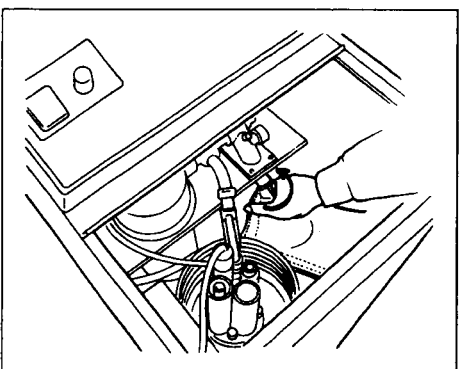

When the filter is blocked, the circulation function will be decreased. When the filter starts to expand caused by the pressure of the dampening solution, replace the filter.

2-1 Outline

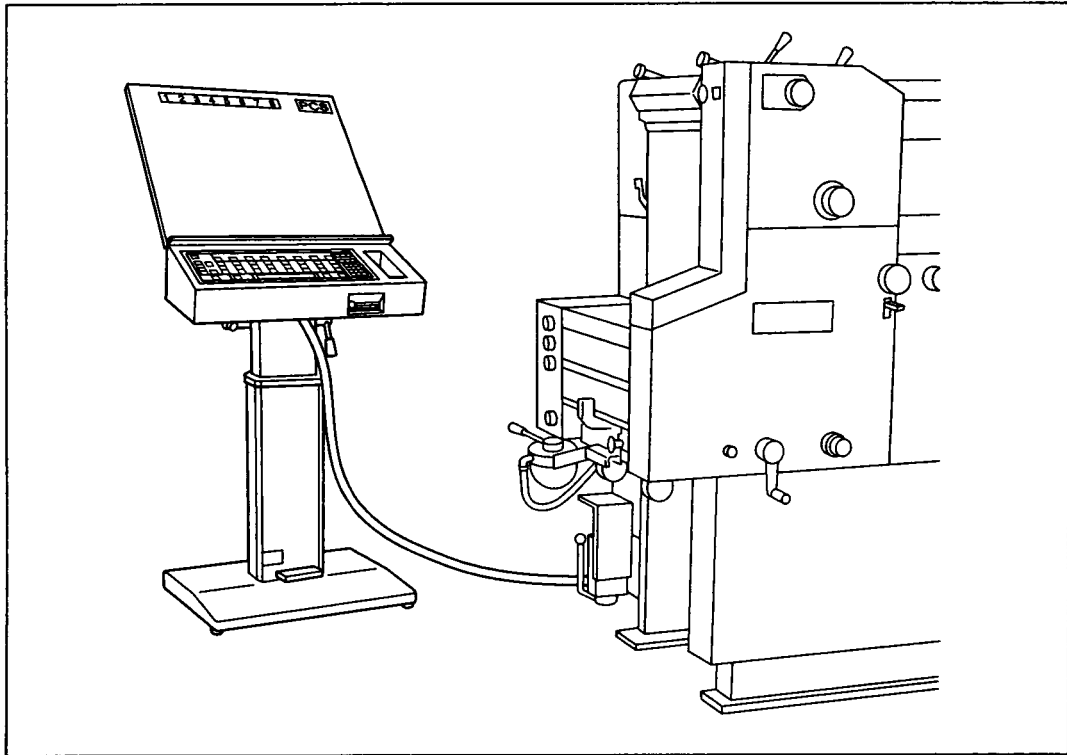

This device is made up of the remote control ink fountain and operation stand. With the input from the operation stand, the remote control opening and closing of each ink fountain key is done.

The ink fountain key opening and closing data can be saved on a floppy disk. This data can be read again, and is used to preset the ink fountain key.

- (Note)
1. When mounting the cables between the press and operation stand, fix the cables with the cable cover so as not to obstruct the operators working area around the machine.
 2. For the place where the RYOBI PCS-F is installed, please prepare a light of over 1,500 lux.
 3. The LCD "Liquid Crystal Display" is used for the message indication on the operation stand, therefore do not install the operation stand in a place with a high temperature [over 35°C (95°F)] and high humidity. If it is used under such conditions, the image brightness of the display may not be even.

2-2 Specifications

Ink fountain key pitch (Operation stand adjustment button pitch)	43 mm (1.69") [both ends : 36 mm (1.42")]
Indication	Liquid crystal display (LCD)
Number of ink fountain keys	8
Memory capacity	3.5 inch floppy disk (2DD : 112 data files, 2HD : 224 data files)
Height adjustment	Gas spring pedal type [808 - 1,153 mm (31.81 - 45.39")]
Angle adjustment	Lever type (0 - 45°)
Dimensions (L x W x H)	710 x 600 x 808-1,153 mm (2'4" x 1'11" x 2'8" - 3'9") (When the inspection table is flat.)
Net Weight	39.5 kg (87 lbs.)

Design and specifications are subject to change without notice.

[Handling of the floppy disk]

1. While the lamp of the floppy disk drive lights, do not take out the floppy disk. If taking it out, the data on the disk may be damaged.
2. When opening the write protect notch of the floppy disk, the data cannot be erased or written over.

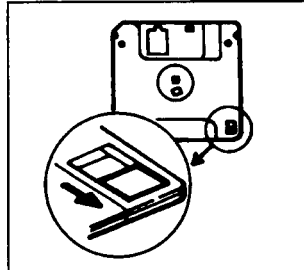

3. The data before power is turned OFF is saved in the RYOBI PCS-F memory, but the data may be broken. At this time, the following message is indicated.

**INTERNAL DATA IS BROKEN
PRESS ESC KEY**

Please copy the important data onto a floppy disk.

4. Be careful not to allow ink to adhere on the floppy disk. If a floppy disk with ink adhered is used, floppy disk drive trouble will result.

[Handling of the liquid crystal display]

The liquid crystal display (LCD) is used for the message indication on the operation stand. Please be careful of the following points.

1. Never put anything on the display surface or place strong shocks on it.
2. Due to the properties of the LCD, there may be times when an area of the LCD always lights or goes off. (However, this is not trouble.)
3. If the same message is displayed for a long period, the reflection may be slightly left on the display. If this happens, turn the power OFF once and after a few minutes, turn the power ON again, and the display should return to the normal condition.

2-3 Name and Function of Each Part

1) Ink fountain manual operation panel

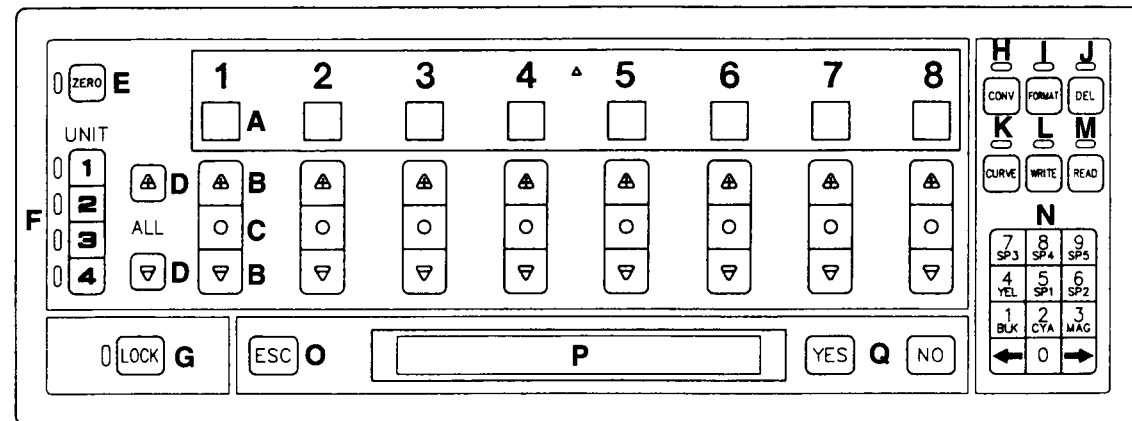

A. Ink fountain key opening volume display

Each ink fountain key opening volume is shown by the digital display.

B. Ink fountain key opening/closing button

This is used when adjusting the opening and closing volume of each ink fountain key.

When pushing the button, each ink fountain key on the selected unit will open and the ink volume will be increased.

When pushing the button, the ink fountain key on the selected unit will close and the ink volume will be reduced.

C. Ink fountain key lock button

When pushing this button, the lamp will light. Even when pushing the ink fountain key opening/closing button (B), the ink fountain key will not open or close. When pushing this button again, the lamp will go off and the lock will be released.

D. Ink fountain key total opening/closing button

This button is used when adjusting the opening and closing volume of all the ink fountain keys at the same time.

When pushing the button, all the ink fountain keys on the selected unit will open.

When pushing the button, all the ink fountain keys on the selected unit will close.

(Note) The ink fountain key with the ink fountain key lock button (C) lighted will not move.

E. Ink fountain key 0 point reset button

When pushing this button, the lamp will light. In this condition, when pushing the unit selection button (F) and next pushing the button, all the ink fountain keys on the selected unit return to the "0" point.

F. Unit selection button

When pushing this button, the lamp will light. The remote control of the opening/closing of the ink fountain keys on the selected unit can be done.

(Note) The buttons and will not function.

G. Lock button

When pushing this button, the lamp will light. At this time, when pushing any button (A through F) on the ink fountain manual operation panel, the operation cannot be done.

This button is used to prevent an operation mistake. When pushing this button again, the lamp will go off and the lock will be released.

Ink fountain preset panel

H. Convert button

When pushing this button, the lamp will light. This is used to copy the data on the unit selected by using the unit selection button to the other unit.

I. Format button

When pushing this button, the lamp will light. This is used to format the floppy disk.

J. Data clear button

When pushing this button, the lamp will light. This is used to clear the data on the floppy disk.

K. Color/conversion curve number set button

When pushing this button, the lamp will light. This is used to input the color and conversion curve number to each unit.

When inputting the data of the device for measuring image area of plate (DEMIA) or ink volume setter, the conversion curve number is used.

L. Data saving button

When pushing this button, the lamp will light. This is used to save the data for each unit on the floppy disk.

M. Data reading button

When pushing this button, the lamp will light. This is used to read the data on the floppy disk.

N. Number input button

This is used to input the job number when saving the data on the floppy disk.

Also this is used to input the color and conversion curve number on each unit.

O. Reset button

This is used to release the button operation (H through M) on the ink fountain preset panel and the button operation of the ink fountain key 0 point reset button (E).

P. Message display

The next operation message is displayed.

Q. YES/NO button

When pushing the button according to the message on the message display (P), you can go to the next process. When pushing the button, you can return to the preceding process.

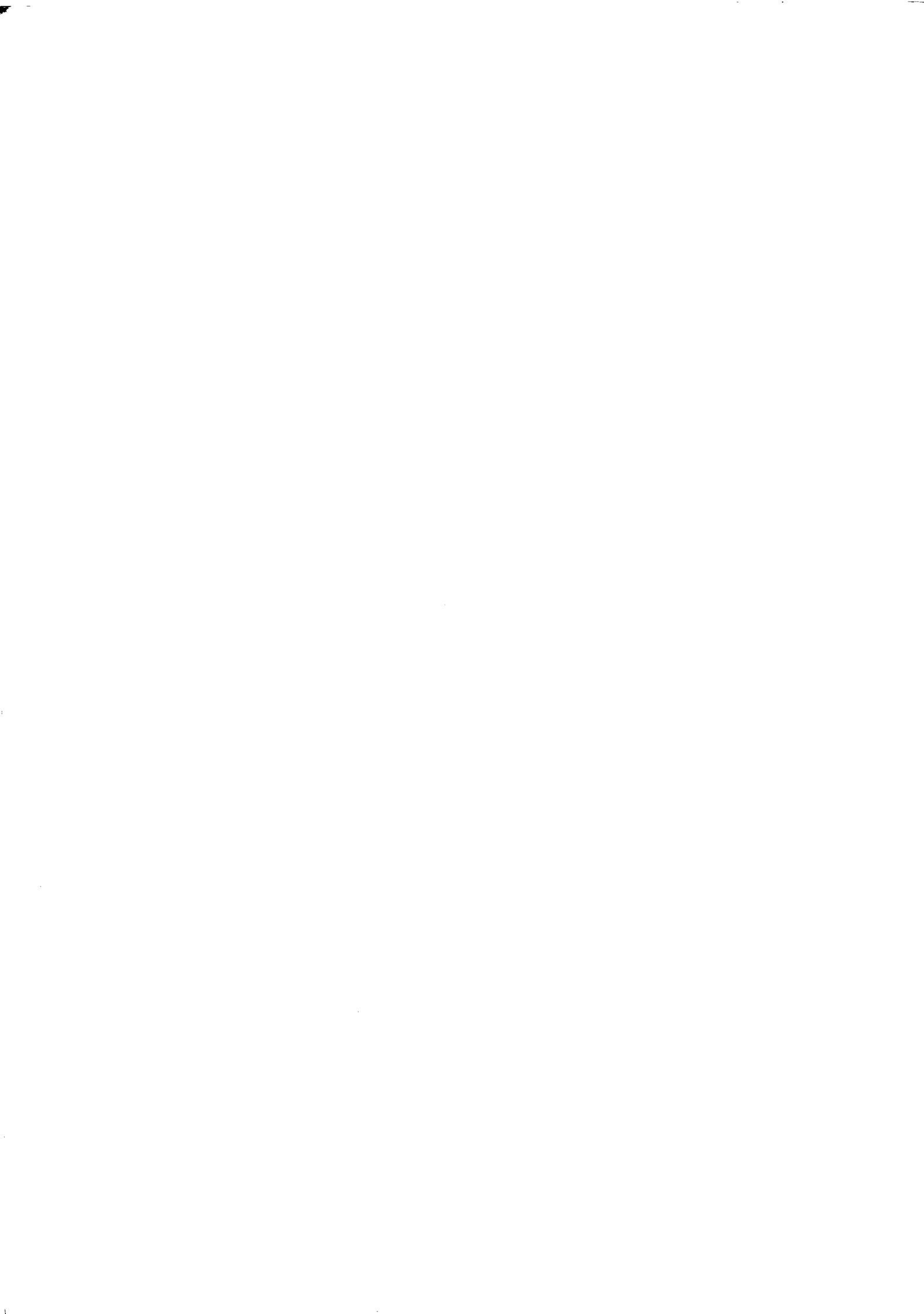

2) Stand section

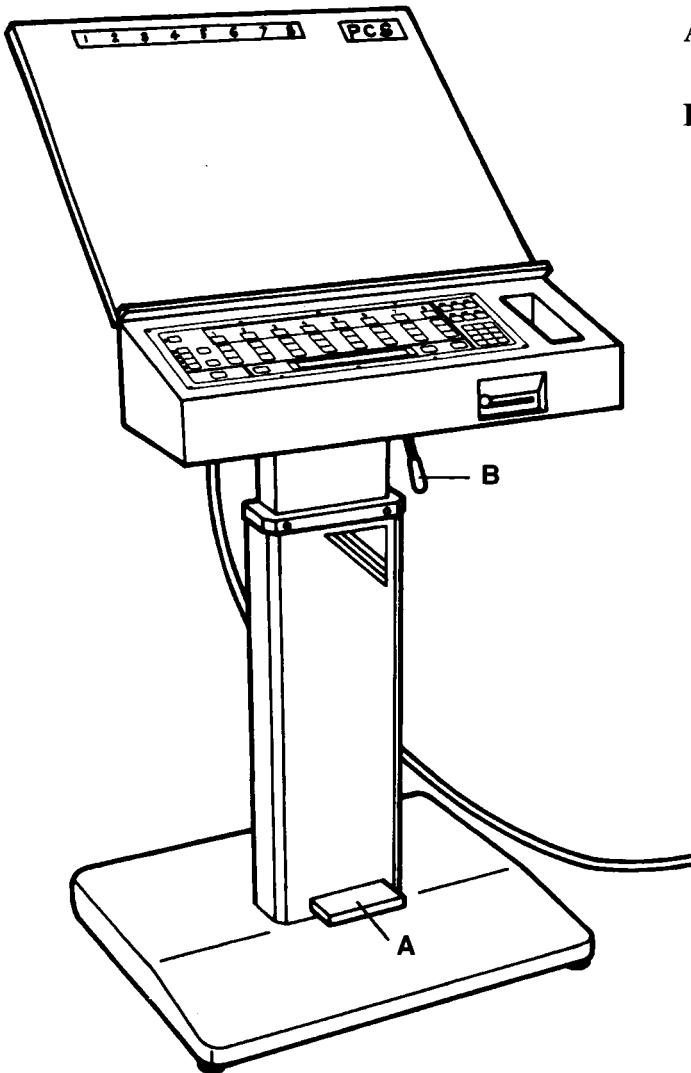

A. Height adjustment pedal

Height of the inspection table can be adjusted.

B. Angle adjustment lever

Angle of the inspection table can be adjusted and fixed.

2-4 Operation Procedures

(Reference) When the following operation process is indicated in the message display, the contents are explained in the . Please refer to this.

1. Setting the Ink Fountain Key (Manual Operation)

The ink fountain key opening volume setting data can be saved on a floppy disk.

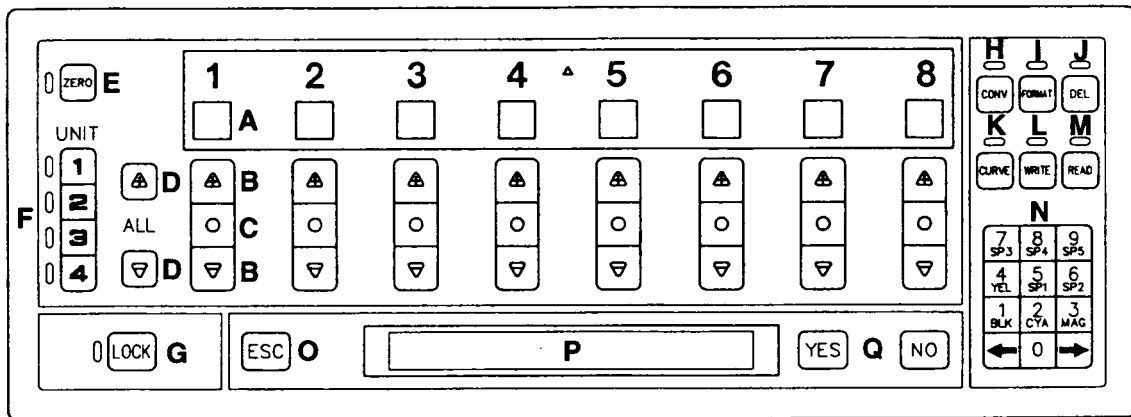

1. Check that each button (H through M) on the ink fountain preset panel is OFF.
2. Check that the lock button (G) is OFF.
3. Select the unit by using the unit selection button (F).
4. Adjust the total ink fountain key opening volume while watching the ink fountain key opening volume display (A) by using the ink fountain total opening/closing button (D).
5. Adjust each ink fountain key opening volume while watching the ink fountain key opening volume display (A) by using each ink fountain key opening/closing button (B).

3. Saving the Ink Fountain Key Opening Volume Data

This is the method to save the total ink fountain key opening data on the selected unit.

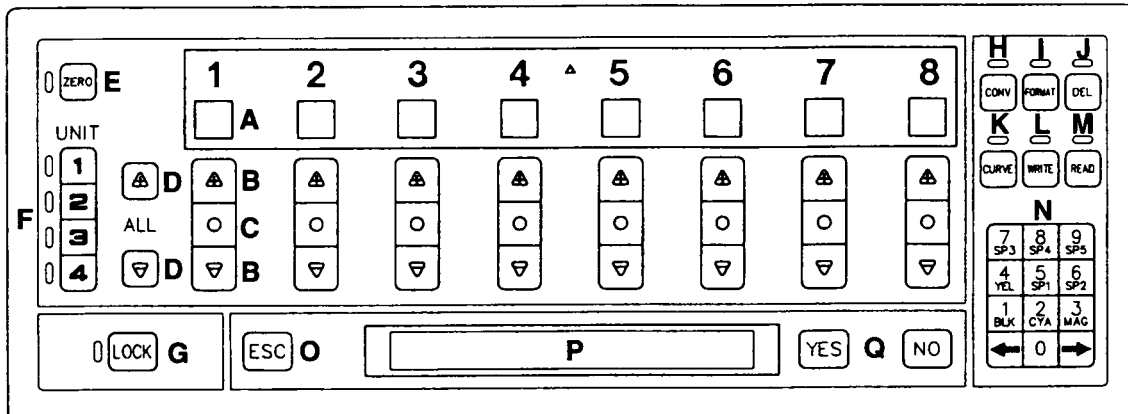

1. Check that each button (H through M) on the ink fountain preset panel, ink fountain key 0 point reset button (E), and lock button (G) are OFF.
2. Push the data saving button (L).

INPUT JOB NO. AND PRESS YES KEY
 JOB NO. []

3. Input the job No. by using the number input buttons (N). The job No. is the number that is used to save and call up the data and can be inputted by using the number from 1 figure to 8 figures. For example, input the "1". Push the **YES** button.

JOB NO. [1]
 INSERT DISK AND PRESS YES KEY

4. Insert the formatted floppy disk and push the **YES** button.
5. When completing data saving on the floppy disk, a buzzer will sound 3 times, and the lamp on the data saving button (L) will go off automatically.
The following message is indicated on the message display (P) for 2 seconds.

WRITING COMPLETED

(Note) If the same job No. is already used on the floppy disk, the following message is indicated on the message display (P).

SAME JOB NO. EXISTS. REWRITING. OK?
 YES OR NO

When pushing the **YES** button, the data is saved over the old data. (The job No. 1 data on the floppy disk is deleted and the new data is saved for the job No. 1.)

When pushing the **NO** button, you can restart from the step 2 above.

4. Reading and Presetting the Ink Fountain Key Opening Data

The data read from the floppy disk will be presetted to move the ink fountain keys.

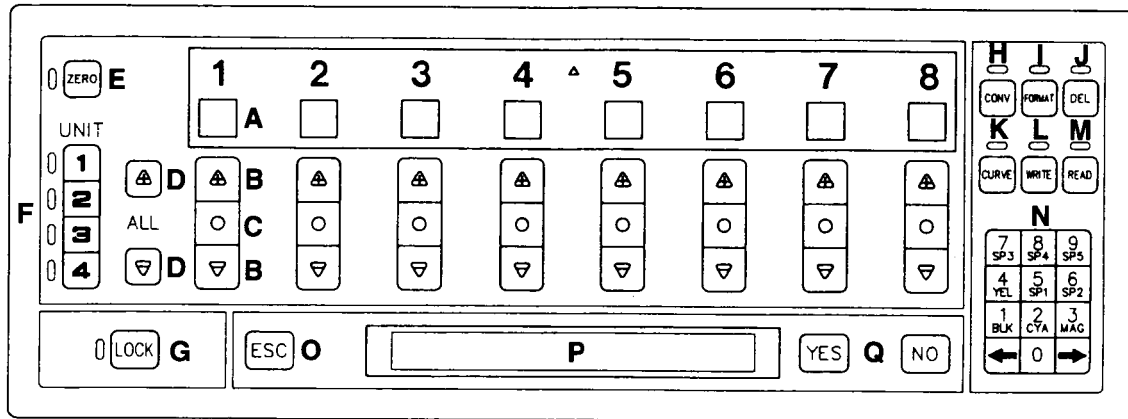

1. Check that each button (H through M) on the ink fountain preset panel, ink fountain key 0 point reset button (E), and lock button (G) are OFF.
2. Insert the floppy disk with the saved data and push the data reading button (M).

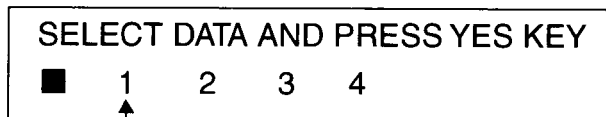

The job No. of the saved data is indicated.
For example, the job No. from 1 to 4 is inputted.

3. Move the cursor by using the or button of the number input buttons (N) and select the data you want to read and push the button. (For example, select the job No. 2.)

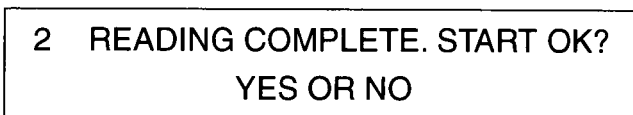

4. Push the button.
5. The lamp on the unit selection button (F) will light in the order and preset the ink fountain opening volume on each unit to the data read.
During presetting, the following message is indicated on the message display (P).

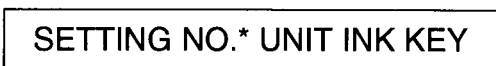

5. Returning to the Ink Fountain Key 0 Point

The ink fountain key opening volume on the unit selected by using the unit selection button can be returned to “0” by using the ink fountain key 0 point reset button.

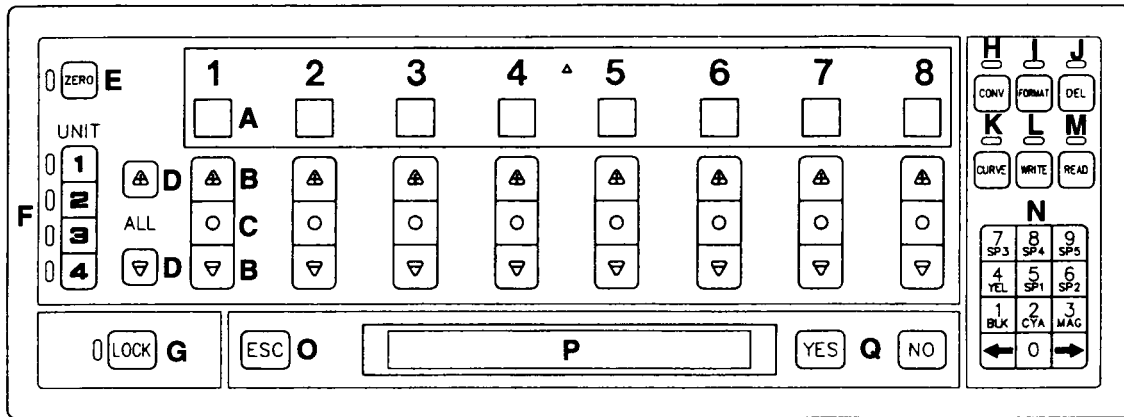

1. Check that each button (H through M) on the ink fountain preset panel is OFF.
2. Push the ink fountain key 0 point reset button (E).

ALL INK KEYS ARE CLOSED. SELECT UNIT

3. Select the unit that you want to return the ink fountain key opening volume to “0” by using unit selection button. (At this time, you can select both the first and second units.)

**ALL SELECTED INK KEYS ARE CLOSED
YES OR NO**

4. Push the button to return the ink fountain keys on the selected unit to “0” in order automatically. At this time, the following message is indicated on the message display (P).

**ALL NO.* UNIT INK KEYS ARE CLOSED
WAIT A MINUTE**

5. When completed, the ink fountain key 0 point reset button (E) lamp will go off automatically.

6. Copying the Ink Fountain Key Opening Data

You can copy the ink fountain key opening data on the indicated unit to the other unit.

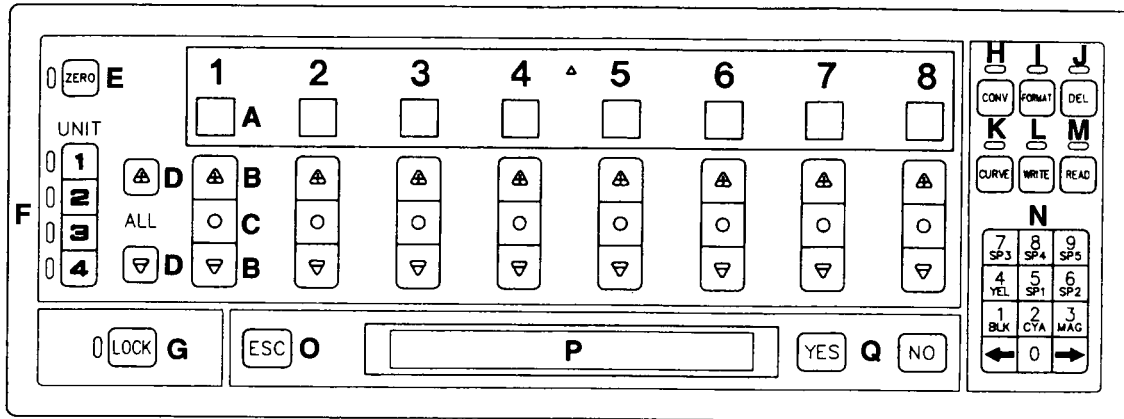

1. Check that each button (H through M) on the ink fountain preset panel, ink fountain key 0 point reset button (E), and lock button (G) are OFF.
2. Push the convert button (H).

DATA IS COPIED TO OTHER UNITS. OK?
YES OR NO

3. Push the YES button.
The setting unit selection button (F) lamp will light in order and the following message is indicated on the message display (P).

SETTING NO.* UNIT INK KEY

4. When completing the copying, a buzzer will sound 3 times and the convert button (H) lamp will go off automatically.

7. Deleting the Data from a Floppy Disk

You can delete any unnecessary data from a floppy disk.

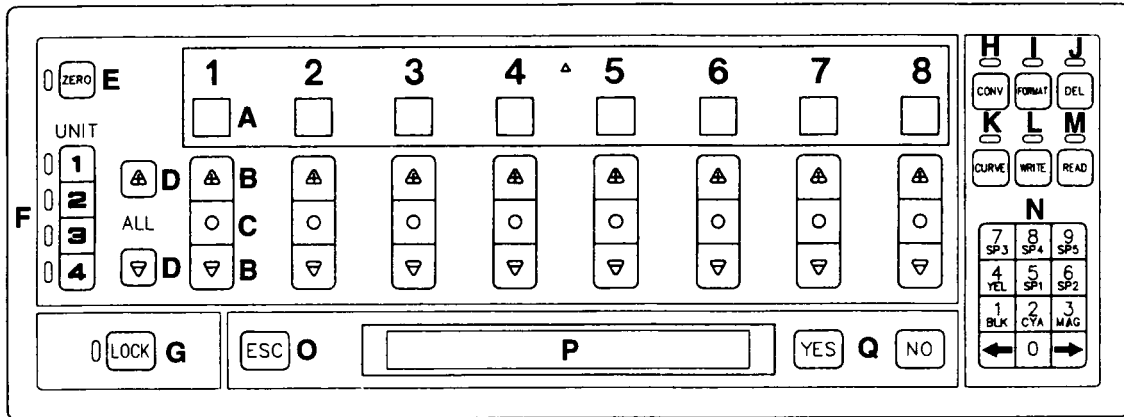

1. Check that each button (H through M) on the ink fountain preset panel, ink fountain key 0 point reset button (E), and lock button (G) are OFF.
2. Insert the floppy disk including the data you want to delete and push the data clear button (J).

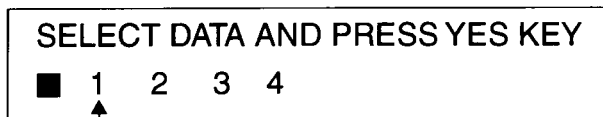

The job No. of the memorized data is indicated.
For example, the job No. from 1 to 4 is inputted.

3. Move the cursor by using the or button of the number input buttons (N) and select the data you want to delete and push the button. (For example, select the job No. 1.)

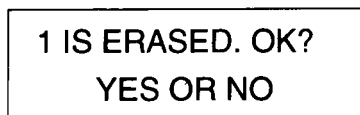

4. When pushing the button, the data deletion starts.
When completed, the data clear button (J) lamp will go off automatically.
The following message is indicated on the message display (P) for 2 seconds.

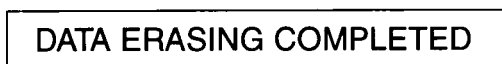

8. Setting the Color and Conversion Curve Number for Each Unit

The PCS-F memory holds 31 kinds of conversion curve that convert the image area percentage of the plate to the ink fountain key opening volume.

You can set the ink color used on each unit and the conversion curve number.

When inputting the data of the device for measuring image area of plate (DEMIA) or ink volume setter, the conversion curve number is used.

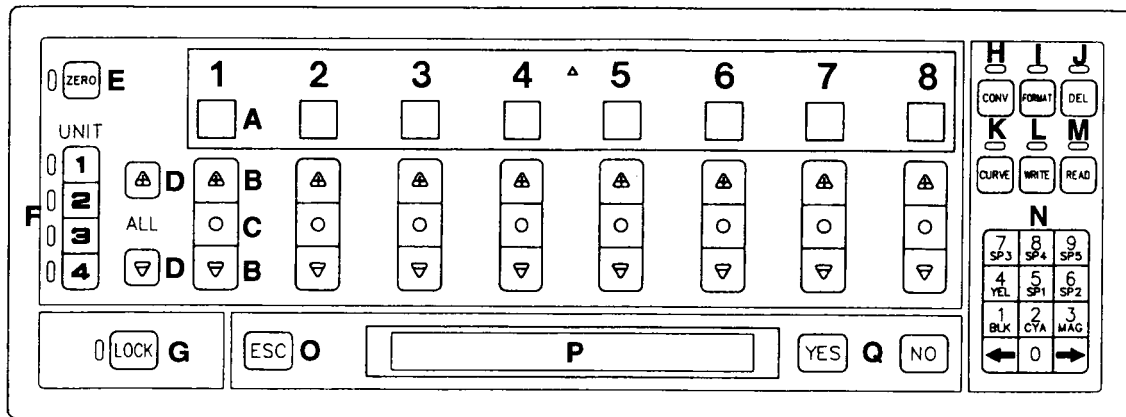

1. Check that each button (H through M) on the ink fountain preset panel, ink fountain key 0 point reset button (E), and lock button (G) are OFF.
2. Push the color/conversion curve number set button (K).

NO.1 UNIT	NO.2 UNIT
[CYA. 3]	[MAG. 1]

3. Set the color on each unit by using the number input buttons (N). Set each color input by using the following button. Move the cursor by using the or button.

- | | |
|---------------------|-----------------------------|
| Black (BLK) | through Special color |
| Cyan (CYA) | |
| Magenta (MAG) | |
| Yellow (YEL) | |

4. Set the conversion curve number for each unit.
For the relationship between the image area percentage of setting conversion curve number and the ink fountain key opening volume, please refer to the table on the next page.
5. When completing the setting, push the button.
The following message is indicated on the message display (P) and the color/conversion curve number set button (K) lamp will go off.

SETTING COMPLETE

(Note) When setting the color, you cannot set the same color on any other unit. If doing this, the following message is indicated on the message display (P).

WRONG COLOR SETTING. PRESS ESC KEY

[The relationship between image area percentage of setting conversion curve number and the ink fountain key opening volume]

1) Normal image

Conversion curve number \ Image area percentage	5%	20%	40%	60%	80%	100%
0	2	6	11	16	20	26
1	3	7	13	18	23	29
2	4	8	15	20	26	32
3	5	9	17	22	29	35
4	6	11	19	25	32	38
5	7	13	21	28	35	41
6	8	15	23	31	38	44
7	9	17	25	34	41	47
8	10	19	27	37	44	50
9	11	21	29	40	47	53
10	12	23	31	43	50	56

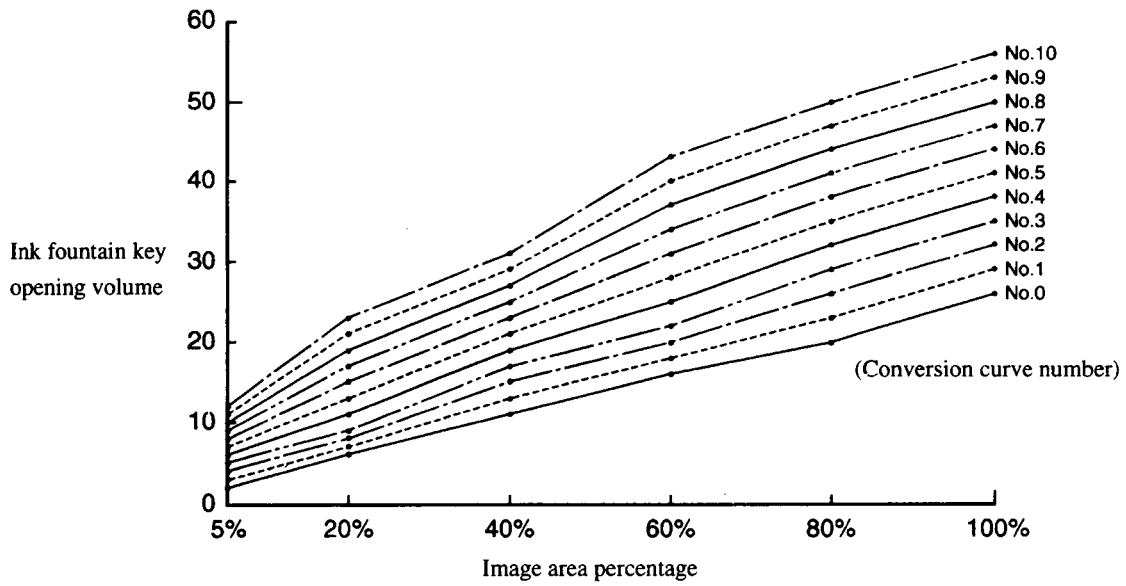

2) When wanting to increase the contrast of the highlight section (below 40% of the image area percentage).

Conversion curve number \ Image area percentage	5%	20%	40%	60%	80%	100%
11	2	9	15	19	23	26
12	3	11	17	22	26	29
13	4	13	19	25	29	32
14	5	15	22	28	32	35
15	6	17	25	31	35	38
16	7	19	28	34	38	41
17	8	21	31	37	41	44
18	9	24	34	40	44	47
19	10	27	37	43	47	50
20	11	30	40	46	50	53

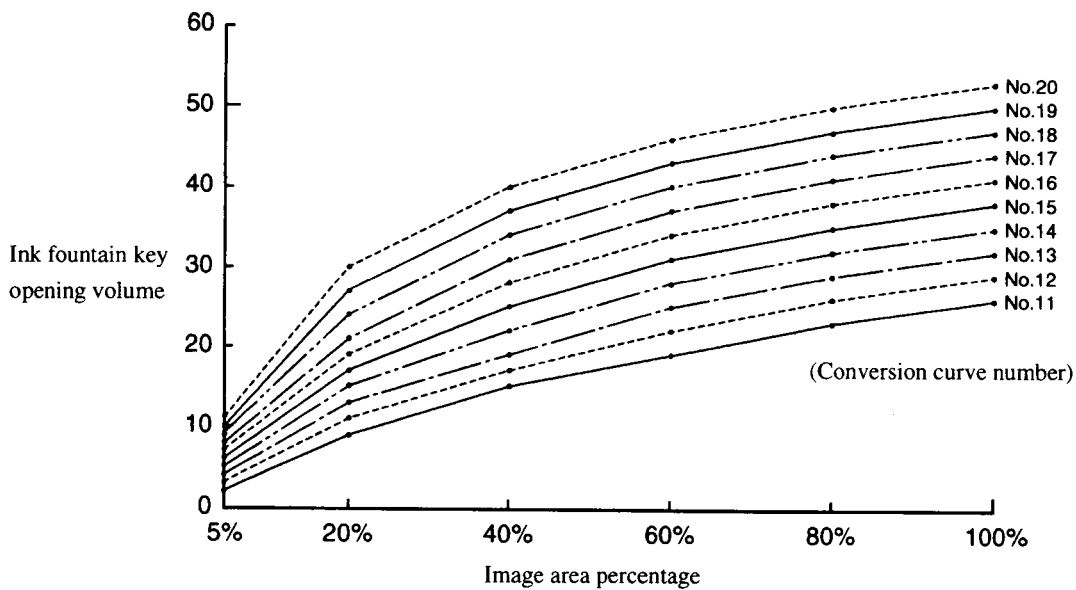

3) When wanting to increase the contrast of the shadow section (above 60% of the image area percentage).

Conversion curve number \ Image area percentage	5%	20%	40%	60%	80%	100%
21	2	4	6	9	13	18
22	3	5	8	12	16	22
23	4	6	10	15	19	26
24	5	7	12	18	23	30
25	6	9	15	21	27	35
26	7	11	17	24	31	40
27	8	13	20	27	35	45
28	9	15	22	30	39	50
29	10	17	25	33	43	55
30	11	19	27	36	47	60

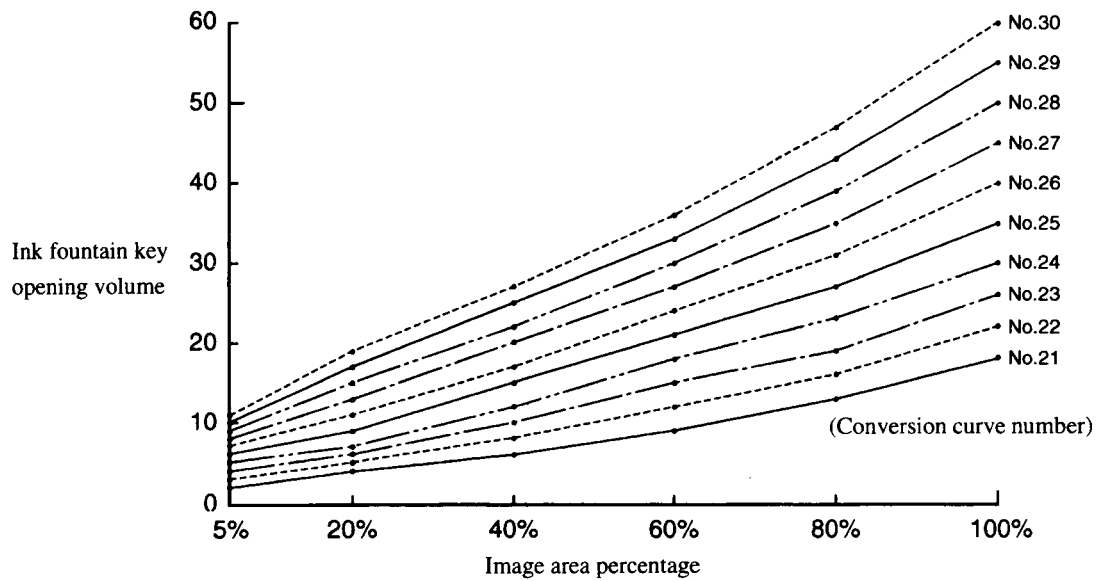

9. Setting the Ink Section

1) Set the ink fountain.



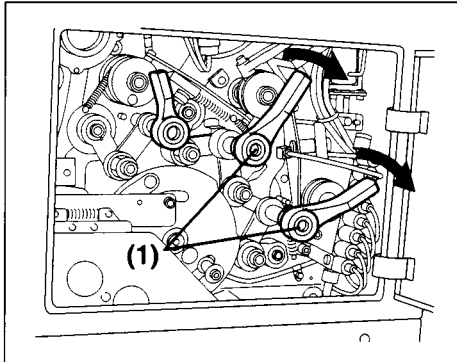

CAUTION

Stop the machine before setting. Failure to follow this instruction may result in an injury.



WARNING

Close the cover opened after setting. Failure to follow this instruction may result in a serious injury.

Open the non operation side cover and shift the ink form roller release lever (1) in the direction of the arrow ( ,  position). After setting the lever, close the cover opened.

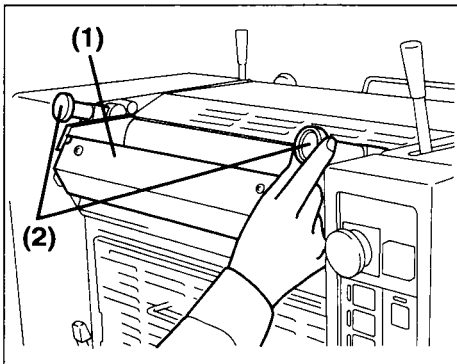

Push the ink fountain (1) against the ink fountain roller, and put the fixing knobs (2) into the brackets. Then tighten the knobs to fix the fountain.

<< NOTICE >>

When turning the ink fountain roller with no ink in the ink fountain, the ink fountain roller may be damaged, therefore please be careful.

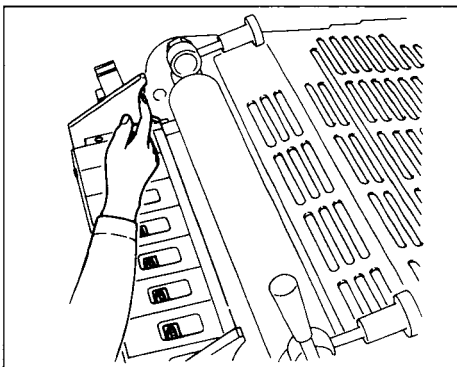

<< NOTICE >>

Before setting the ink fountain, wipe off any foreign particles in the ink fountain and on the ink fountain roller. Apply oil on the side edges of the ink fountain. This oiling assures smooth fountain roller rotation.

2) Control the ink feeding volume.

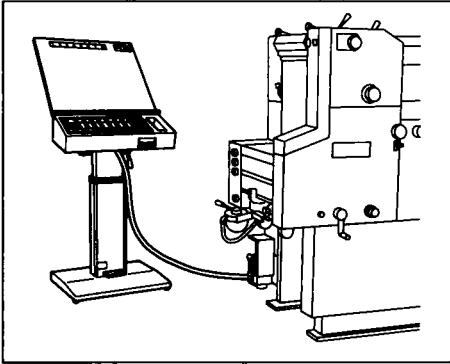

Put the ink in the ink fountain.

Control the ink fountain key by using the PCS-F. Please refer the details "Operation Procedures of the Operation Stand".

2-5 Maintenance after the Printing

1. Cleaning the Ink Fountain and Ink Fountain Roller

<< NOTICE >>

Be sure to return the ink fountain key opening volume to "0" before cleaning the ink section. Please refer the details "5. Returning to the Ink Fountain Key 0 Point".

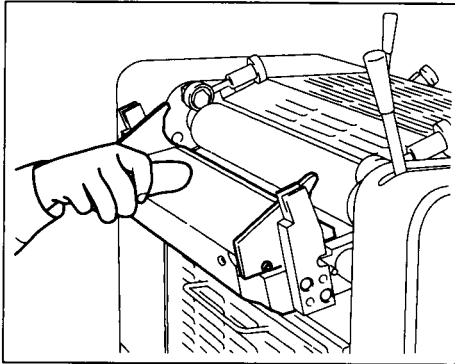

WARNING

Stop the machine before cleaning. Failure to follow this instruction may result in a serious injury.

Remove the ink in the ink fountain.

Loosen the ink fountain fixing knobs and pull the ink fountain downwards. Clean the side edges of the ink fountain roller, both sides of the ink fountain, and edge of the ink fountain key well.

<< NOTICE >>

1. Do not use any powerful corrosive acid or chlorine type cleaning solution on the metal. The metal may corrode when the acid or chlorine reacts with the water.

Example of powerful corrosive chemicals:

Plate cleaner (powerful acid)

Blanket cleaner (chlorine type)

2. If the machine will not be operated for 3 days or more, apply the rust preventive oil on the ink fountain roller after cleaning it.

Also if the printing room environment is one with a high temperature and damp, the metal will easily corrode and rust. Therefore in this environment when not using the machine the following day, apply the rust preventive oil on the ink fountain roller after cleaning it.

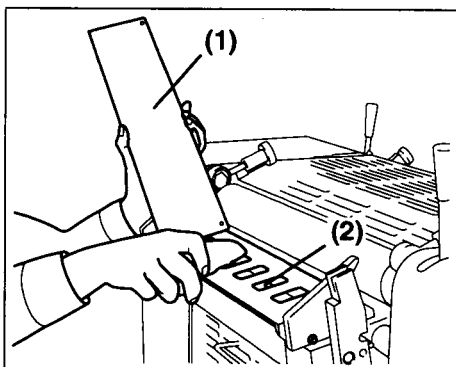

Remove the plate (1) and then clean each ink fountain key. Clean well so that the ink does not remain on the edge of the ink fountain key. Be careful so as not to allow the ink to enter the inside (2). If there is any ink on it, it should be removed completely.

When changing the color, remove the plate (1) and clean the inside (2) following the same procedures above.

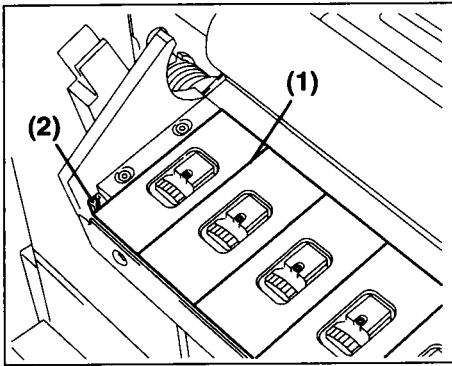

After cleaning, apply spray type oil in each clearance (1) between the ink fountain keys.

(Note) After cleaning it, the plate should be set onto the ink fountain correctly. Then check that the pins (2) are properly in the slots of the plate.

<< NOTICE >>

1. You should use spray type oil that meets following requirements.
 - A spray type oil which has a low viscosity.
(When the temperature is 40°C (104°F), the viscosity of the oil is lower than 10 cst.)
 - A spray type oil which does not damage the resin and rubber.
(Do not use an ester type lubricating oil.)
 - A spray type oil which has the heat-resistant and high rust preventive effect.
 - A spray type oil which does not affect the printing, if the oil and ink mix. (Do not use a silicon type lubricating oil.)
2. Do not use spray type grease.

On the PCS-F, the following error messages will be indicated on the message display when trouble occurs. Before calling for after sales service, please check the following.

Error message	Cause	Countermeasure
INTERNAL DATA IS BROKEN PRESS ESC KEY	There is trouble with the inside data caused by a dead battery. (This message is indicated when turning the power ON.)	When pushing the ESC key, the memory will be reformatted.
MISTAKE IN UNIT COLOR SETTING PRESS ESC KEY	When setting the conversion curve, the same color is set on the multiple units.	Set a different color on each unit.
MISTAKE IN CONVERSION CURVE SETTING PRESS ESC KEY	Over 30 conversion curve numbers have been set by the conversion curve.	Set a conversion curve number below 30.
WRONG COLOR SETTING. PRESS ESC KEY INPUT DATA [*** ** * ** * ** *]	The color setting information which is read from the floppy disk has color information which cannot be read by the PCS-F.	Change the color setting of the PCS-F or read the same data as the color setting of the PCS-F.
PROBLEM OF DATA PRESS ESC KEY	The data not for this machine is read.	Read out the data of this machine again.
DISK IS NOT INSERTED PRESS ESC KEY	The READ, WRITE, FORMAT, or DEL button is pushed without inserting the floppy disk.	Insert the floppy disk and do the operation again.*1
DISK IS PROTECTED FROM WRITING PRESS ESC KEY	The floppy disk write protect notch is open.	Close the write protect notch.*1
DISK IS NOT FORMATTED PRESS ESC KEY	The floppy disk is not formatted.	Do the formatting of either a 2HD or 2DD floppy disk.*1

(Note) *1 When the same message is shown over and over again, this may indicate trouble with the hardware. Please contact your service technician.

Error message	Cause	Countermeasure
DISK IS FULL AND UNABLE TO WRITE PRESS ESC KEY	The data cannot be saved on the floppy disk. (The disk is full.)	Use a floppy disk with more space.*1
FAILED IN WRITING PRESS ESC KEY	There is trouble with the floppy disk or floppy disk drive.	Replace the floppy disk with a new one.*1
NO DATA FILE PRESS ESC KEY	The READ or DEL button is pushed when the floppy disk does not have the data.	Use the floppy disk with the data on it.*1
ERROR00 * * = 1-3	Communication trouble to the key board.	Please write down the message shown on the display, then contact your service technician.
ERROR00 * * = 4, 5	Communication trouble to the motor control board.	Please write down the message shown on the display, then contact your service technician.
ERROR010 ** ** 00 00 * = 0-9, A-F	Other trouble	Please write down the message shown on the display, then contact your service technician.

(Note) *1 When the same message is shown over and over again, this may indicate trouble with the hardware. Please contact your service technician.

Blanket Cleaning Device

3-1 Outline

The blanket of each unit can be cleaned automatically by operating this device.

3-2 Name and Function of Each Part

1) Delivery section operation panel

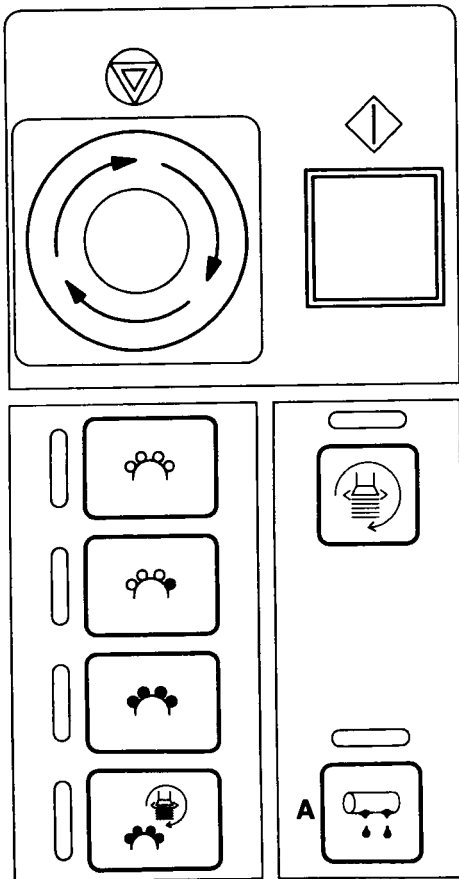

A. Blanket cleaning button

When pushing this button while the machine is running, the lamp will light. The blanket on the unit selected by using the unit selection button will be cleaned.

After the number of rotations set by the cycle setting is completed, the lamp will go off.

(During the printing, it cannot be operated.)

2) Blanket cleaning device

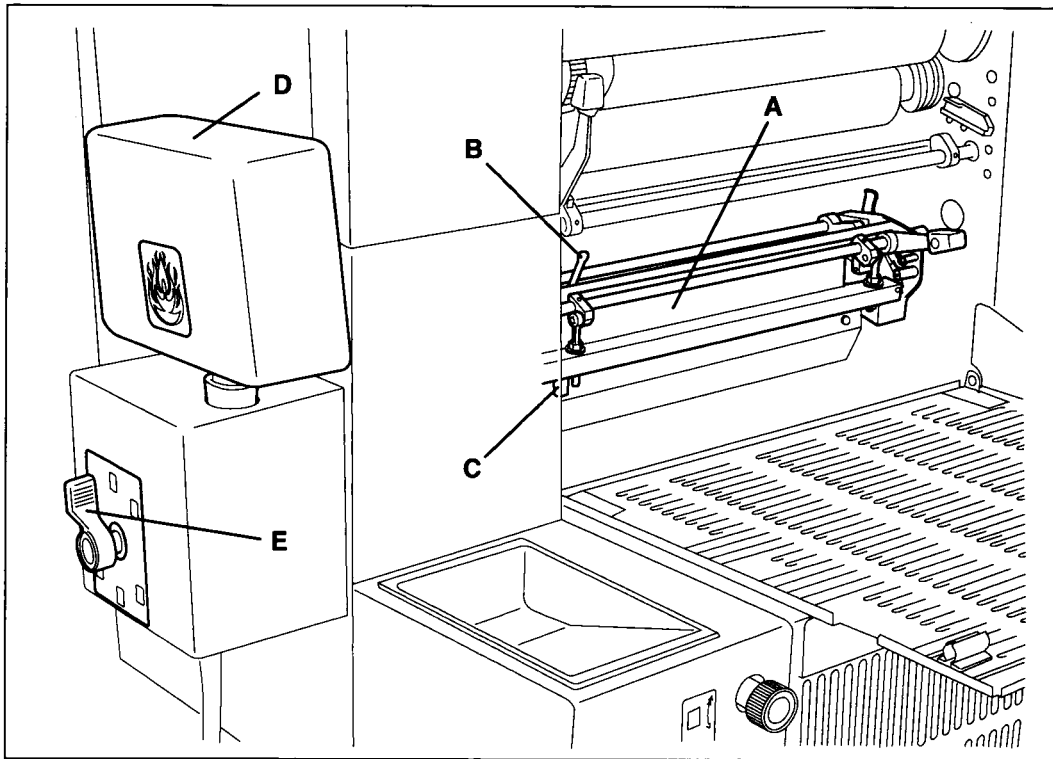

A. Blanket cleaning device

When pushing the blanket cleaning button, the device will clean the blanket automatically.

B. Roller release lever

When shifting this lever to the blanket cylinder side, the cleaning roller and squeeze roller will be released.

C. Sponge roller rotation lever



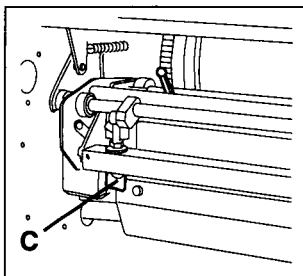



When pushing this lever, the sponge roller will be rotated and the clean part of the sponge roller can be positioned to contact the cleaning roller.



D. Blanket cleaning solution bottle

This bottle is the container that holds the blanket cleaning solution.

E. Blanket cleaning solution changeover lever

- 1  ... The blanket cleaning solution is supplied to the first blanket cleaning device.
- 2  ... The blanket cleaning solution is supplied to the second blanket cleaning device.
- 12  ... The blanket cleaning solution is supplied to both the first and second blanket cleaning devices.
- 1  ... The blanket cleaning solution is drained from the first blanket cleaning device.
- 2  ... The blanket cleaning solution is drained from the second blanket cleaning device.
- 12  ... The blanket cleaning solution is drained from both the first and second blanket cleaning devices.

3-3 Operation Procedures

1) Set the blanket cleaning device.

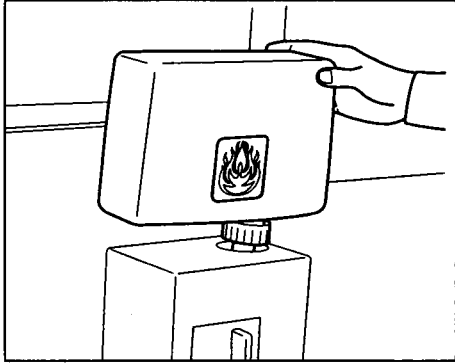

Put the cleaning solution into the bottle and mount it on the bracket.
Never use a blanket cleaning solution which has a flash point lower than 55°C (131°F).

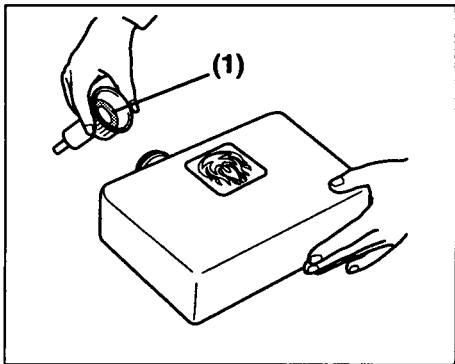

(Note) On the inside of the bottle cap, there is a rubber packing (1). If the bottle is mounted without the packing, the cleaning solution in the cleaning tray may overflow. So please be careful.

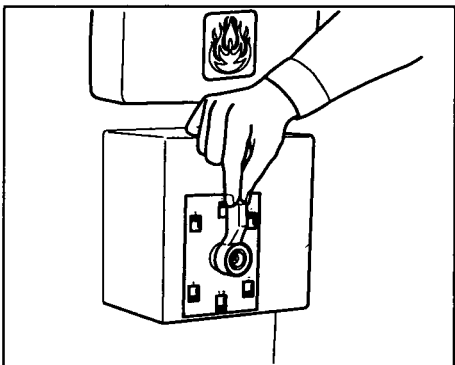

When shifting the blanket cleaning solution changeover lever in the unit to be used to the  position, the cleaning solution is supplied in the tray. With the lever at this position, the proper volume of the cleaning solution is automatically supplied into the tray.

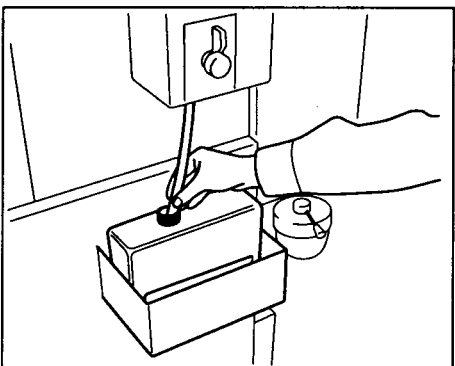

Set the drain bottle (a big bottle, can, or other suitable container).

2) Set the cycle set button.

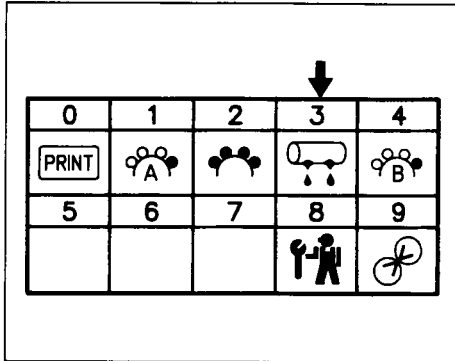

CY-3 ... Blanket cleaning cycle

This is the process that cleans the blanket by the blanket cleaning device cleaning roller. Set the cycle time to be able to properly clean the blanket.

Indication	Cycle type	Setting possible range	Setting pitch	Factory setting value
CY-3	Blanket cleaning cycle	20 - 65 rotations	Every five rotations	20 rotations

[Cycle setting procedures]

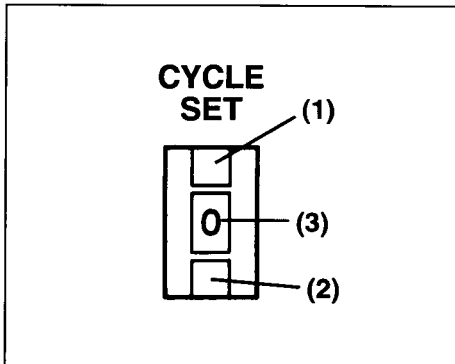

There are 2 cycle setting buttons (1) and (2).

When pushing either button, the cycle indication (3) in the middle changes and at the same time, the cycle indication and setting value will be indicated on the counter panel on the delivery section operation panel.

(Note) When pushing the button (1), the cycle set number is increased and when pushing the button (2), the cycle set number is reduced. The numbers can be changed from "0" to "9".

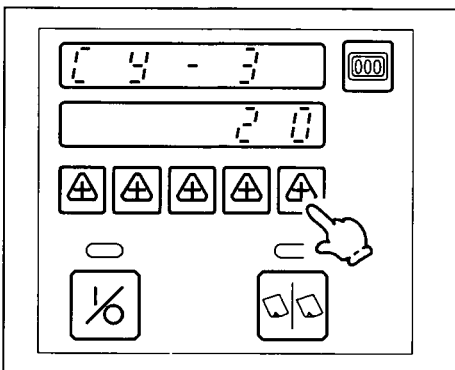

The setting value is set by using the counter set button on the delivery section operation panel.

(Note) After completing the setting of the set value, return the cycle set button indication to "0".

3-4 Maintenance



WARNING

Push the emergency stop button to stop the machine before mounting and removing the blanket cleaning device. Failure to follow this instruction may result in a serious injury.

1) Drain the blanket cleaning solution.

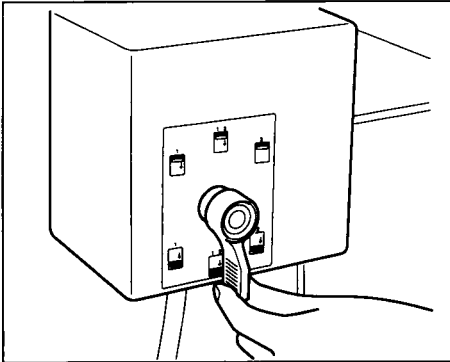

Set the blanket cleaning solution changeover lever at the used unit to the  position to drain the cleaning solution.

Properly dispose of the solution in the waste solution bottle every day.

Please entrust the waste disposal company with the waste solution.

2) Remove the blanket cleaning device and clean it.

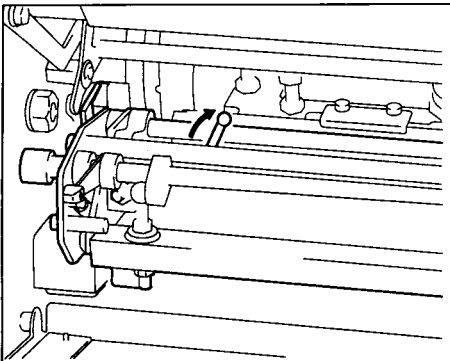

Shift the roller release lever in the direction of the arrow and release the cleaning roller and squeeze roller.

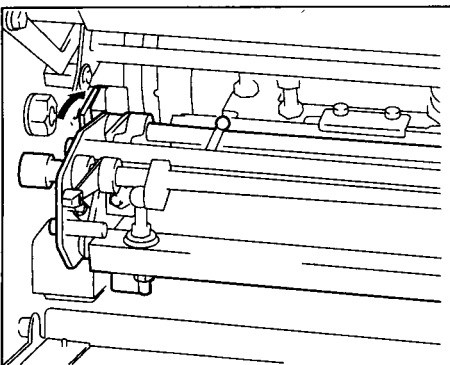

Shift the lock levers (operation side and non operation side) in the direction of the arrow and remove the blanket cleaning device.

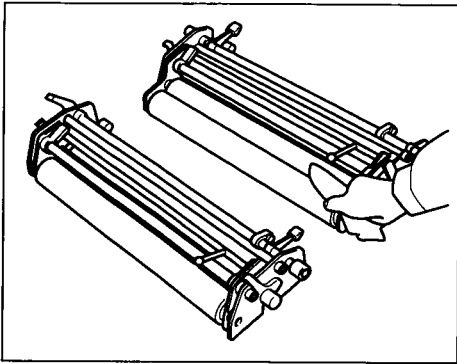

If etching solution or zinc oxide of the plate surface adheres on the cleaning roller, printing problems may be caused. Wipe it off using a cotton rag containing water and cleaning solution every day.

- For the first unit 1 cleaning roller
- For the second unit 2 cleaning rollers

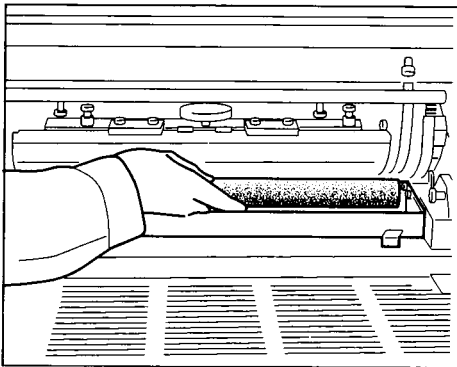

Take out the sponge roller from the cleaning tray.

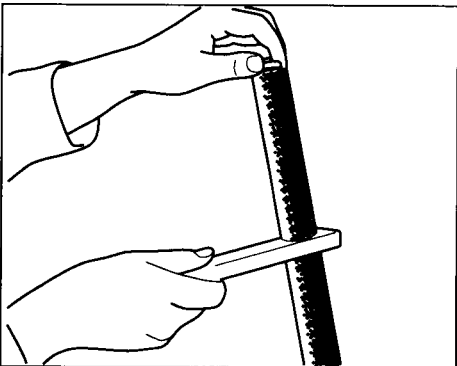

After dipping the sponge roller in the cleaning solution, clean the sponge roller using the sponge roller cleaner by squeezing it out. Repeat this process a couple of times. When using the sponge roller with ink and foreign particles adhered, the blanket cleaning effect will be reduced.

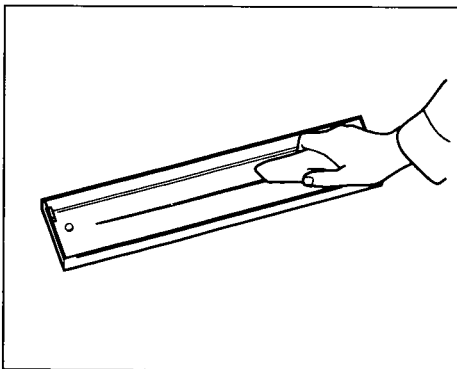

Clean the cleaning tray. Remove the tray and remove any ink and foreign particles adhered in the tray. Since the pipe of the tray is set in the hole, pull the tray straight up.

3) Mount the blanket cleaning device.

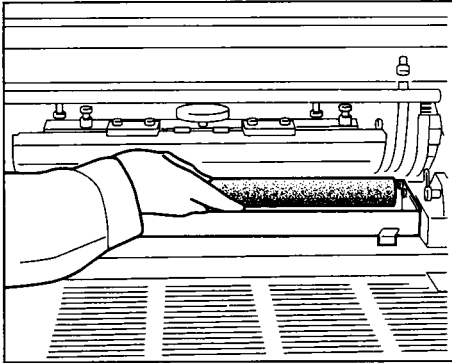

Mount the sponge roller in the cleaning tray.

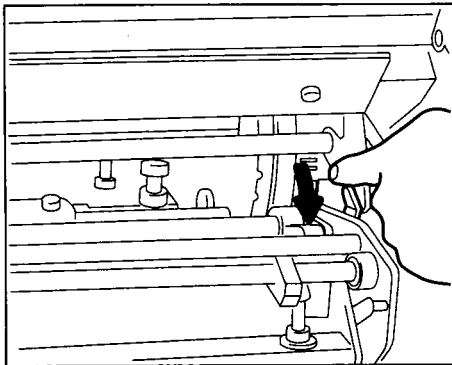

Align the gap sections of the lock levers (operation side and non operation side) with the studs and then mount the cleaning device base body. Shift the lock lever in the direction of the arrow to fix it.

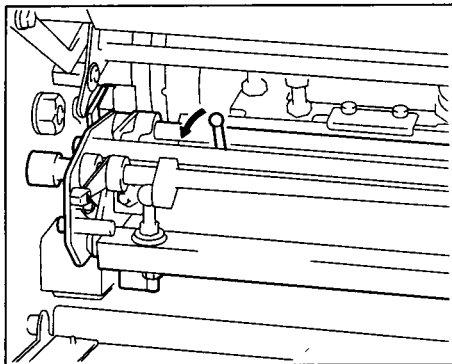

Shift the roller release lever in the direction of the arrow.

3-5 Caution when Replacing the Blanket

When replacing the blanket, first remove the first unit blanket cleaning device and then replace the blanket. For the second unit, the blanket cleaning device does not have to be removed.

RYOBI LIMITED

TOKYO HEAD OFFICE :
3-15-1 SOTOKANDA, CHIYODA-KU
TOKYO, 101-8618, JAPAN
TEL. (03) 3257-1502
FAX. (03) 3257-0223
TELEX J33672 RYOBI

Order No. : M5342 01 001
(Control No. : M5342 01 01-1)

Rev.1/July '99 MP2290609

Printed in Japan