

**RYOBI**

**RYOBI 3302M**  
**TWO-COLOR OFFSET PRESS**

**OPERATION  
MANUAL**



**SAFETY WARNING :** Read this operation manual carefully and be sure that you understand it before using this press.  
Always follow the "SAFETY RULES".

*This manual also includes the explanation of the optional accessories so as to explain the total capabilities of the machine.*

# SAFETY RULES

A person who is operating the press for the first time, and an experienced operator must pay attention to assure safe operation.

The safe operation points listed below are some of the most important ones to follow to operate the press safely. Be sure to always follow them.

## Safe Operation Points

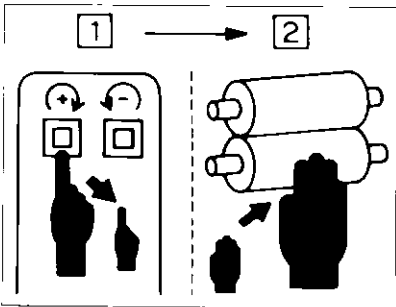

- For safe cleaning, after pushing the inching button, pause and then clean, pause and then push the inching button again.

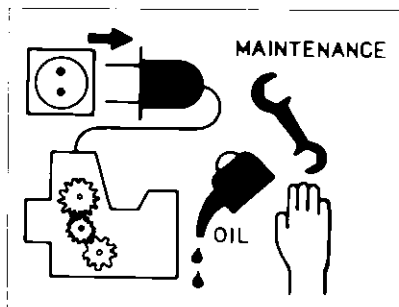

- Turn off the power before lubricating and doing maintenance.

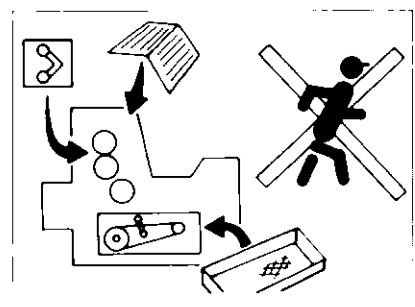

- Mount all covers removed after finishing the maintenance and inspection. Never remove or disconnect the safety devices.

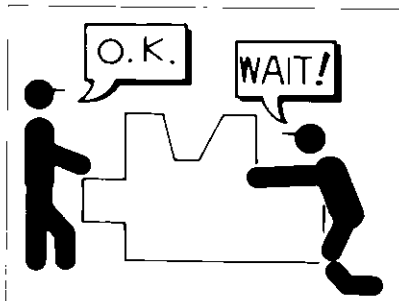

- When working with another person, always be aware of where, and what that person is doing.

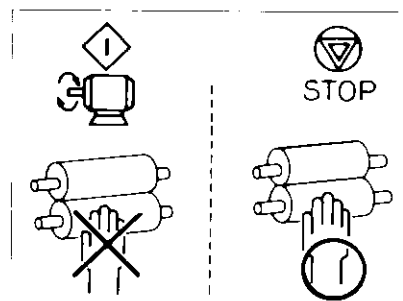

- Stop the press when removing foreign particles on the plate surface or on the roller. Never touch the rotating parts.

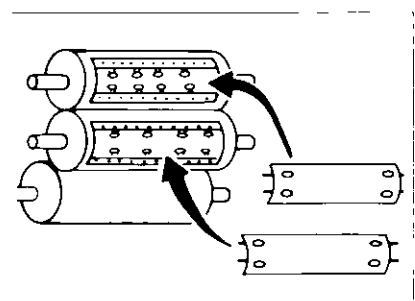

- Be sure that the cylinder gap safety covers are always properly mounted on the plate cylinder and blanket cylinder before operating the press.

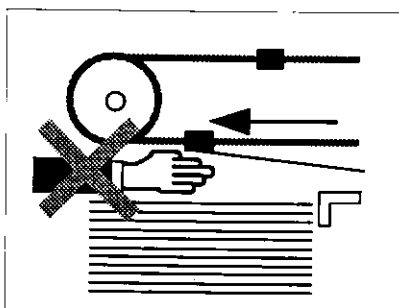

- When the press is running, moving chain and grippers can cause severe hand injury. Do not insert your hand in the press when taking a printing sample off of the delivery pile.

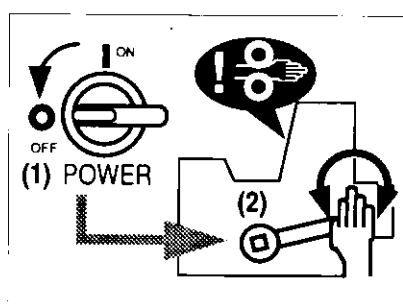

- When an accident occurs, immediately
  - (1) Turn off the power.
  - (2) Rotate the press manually using the handwheel or handle.

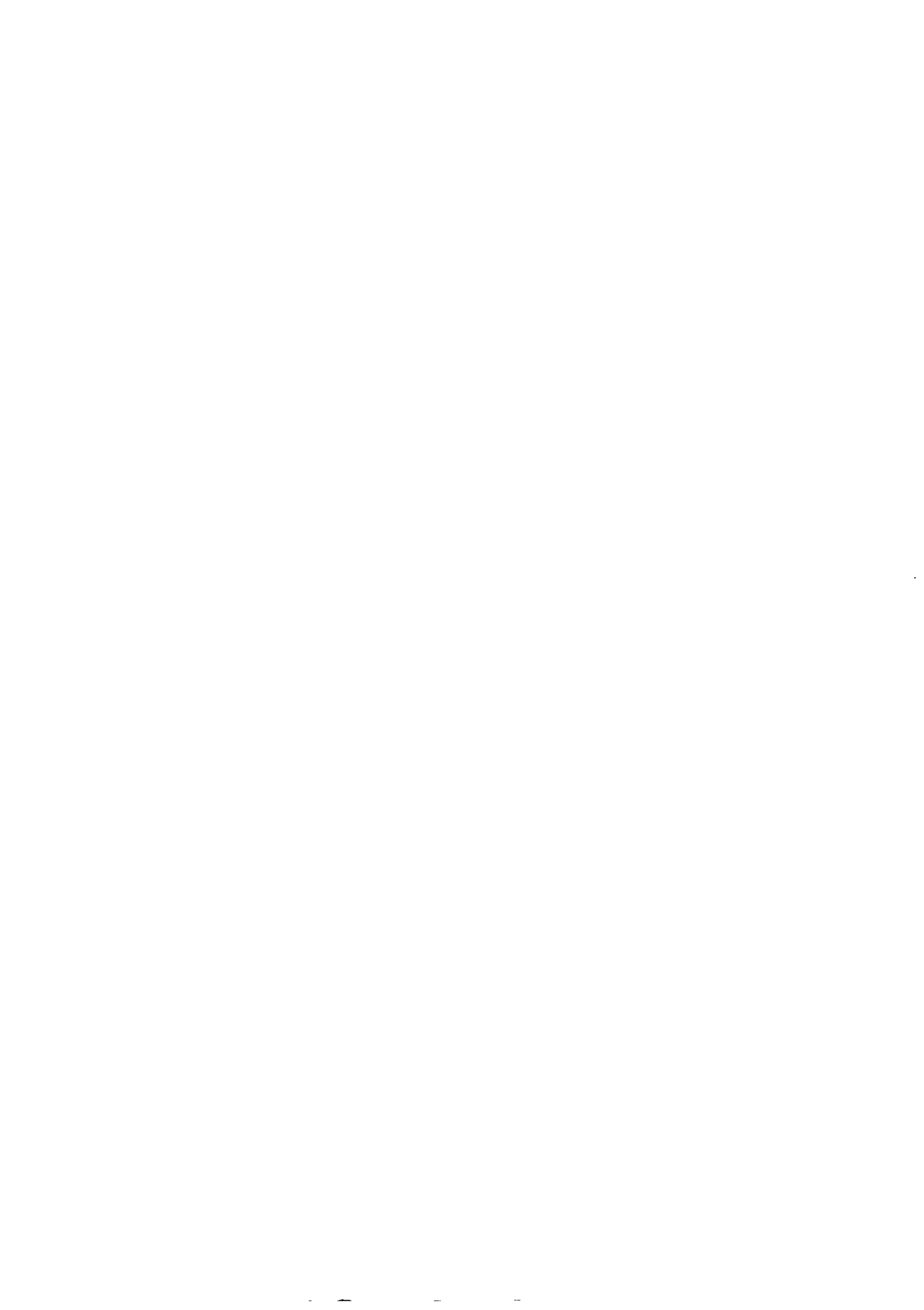

TWO-COLOR OFFSET PRESS  
**RYOBI 3302M**

**OPERATION MANUAL**

**Introduction Edition**

Chapter 2  
Name and Function  
of Each Part

Chapter 1  
Machine Outline

**Machine Operation Edition**

Chapter 5  
Troubles and  
Countermeasures

Chapter 4  
Maintenance and  
Inspection

Chapter 3  
Printing Practice

Chapter 2  
Printing

Chapter 1  
Printing  
Preparation



# **PREFACE**

Thank you for purchasing our press.

Please read this operation manual carefully before using this press to obtain the best printing performance.

We hope this press will contribute to the growth of your company.

# CONTENTS

---

## Introduction Edition

---

### Chapter 1 Machine Outline

1-1 Specifications .....	9
1-2 Roller Arrangement .....	10
1) List of Roller Pressure .....	10
2) Roller Size and Rubber Hardness .....	10
1-3 Cylinder Packing and Printing Starting Line .....	11

### Chapter 2 Name and Function of Each Part

<b>Illustrated Contents</b> .....	12
2-1 Operating Lever .....	14
2-2 Control Panel .....	15
1) Drive Switch .....	15
2) Speed Control .....	16
3) Counter .....	17
4) OK Monitor <span style="border: 1px solid black; padding: 0 2px;">1</span> .....	18
5) OK Monitor <span style="border: 1px solid black; padding: 0 2px;">2</span> (Safety Cover, Safety Device) .....	19
2-3 Control Sub-Panel .....	20
2-4 Sub-Panel .....	21
2-5 Delivery Control Panel .....	21
2-6 Paper Feed Section .....	22
1) Feeder Pile .....	22
2) Feeder .....	24
3) Double Sheet Detector, Feeder Board .....	26
4) Push Side Lay .....	28
2-7 Printing Section .....	30
1) Plate Cylinder, Blanket Cylinder, and Upper Feed Roller .....	30
2) Lateral Image Adjustment, Vertical Image Adjustment, Impression Pressure Adjustment, Plate Pressure Adjustment Device .....	32
2-8 Water Section, Ink Section .....	34
1) Water Section, Ink Section <span style="border: 1px solid black; padding: 0 2px;">1</span> .....	34
2) Water Section, Ink Section <span style="border: 1px solid black; padding: 0 2px;">2</span> .....	36
2-9 Delivery Section .....	38
1) Delivery Section <span style="border: 1px solid black; padding: 0 2px;">1</span> .....	38
2) Delivery Section <span style="border: 1px solid black; padding: 0 2px;">2</span> .....	40
3) Spray Device .....	42
2-10 Accessories .....	44
1) Centralized Oiling System, Ink Roller Cleanup Attachment, Electrostatic Eliminator .....	44
2) Blanket Cleaning Device .....	46

---

# Machine Operation Edition

---

## Chapter 1 Printing Preparation

1-1 Plate Making and Setting the Water Section .....	51
1-2 Setting the Paper Feed Section .....	57
1-3 Setting the Feeder Board .....	64
1-4 Setting the Delivery Section .....	70
1-5 Setting the Ink Section .....	72
1-6 Setting the Blanket Cleaning Section .....	74

## Chapter 2 Printing

2-1 Test Printing .....	75
2-2 Printing .....	80

## Chapter 3 Printing Practice

3-1 Minimum Size Paper (90×130mm) Printing .....	84
3-2 Thin Paper Feeding (Paper with a thickness less than 0.08mm) .....	87
3-3 Paper Feed and Delivery of Curled Paper .....	89
3-4 Single Color Printing .....	90
3-5 Troubleshooting during Printing .....	91

## Chapter 4 Maintenance and Inspection

4-1 Care after Printing .....	93
4-2 Roller Pressure .....	99
4-3 Regular Maintenance .....	103
4-4 Lubrication .....	106
4-5 Supplies .....	108

## Chapter 5 Troubles and Countermeasures

5-1 Troubles and Countermeasures .....	113
--	-----





# Ryobi 3302M

## Introduction Edition

This edition is composed of two chapters.  
Chapter 1 explains the machine outline. Chapter 2 focuses on the name and function of each part. (Including the levers and the buttons.)

Introduction Edition

Chapter 1  
Machine Outline

Chapter 2  
Name and Function  
of Each Part





## Machine Outline

### 1-1 Specifications

Paper Size (Max.)	340 × 450mm (13.39 × 17.72")
Paper Size (Min.)	90 × 130mm (3.54 × 5.12")
Paper Thickness	0.04 ~ 0.3mm (0.0016 ~ 0.012")
Printing Area (Max.)	330 × 438mm (12.99 × 17.24")
Printing Speed	3,000 ~ 10,000 sheets per hour
Plate Size	335 × 485mm (13.19 × 19.09")
Plate Width (Max.)	352mm (13.86")
Plate Clamp Type	Straight edge clamp with plate positioning pins
Over-Blanket Size	344 × 496 × 1.9mm (13.54 × 19.53 × 0.075")
Under-Blanket Size	330 × 460 × 0.6mm (12.99 × 18.11 × 0.024")
Paper Feed System	Universal feeder
Feeder Pile Capacity	440mm (17.32")
Feeder Pile System	Pre-pile
Paper Delivery System	Chain delivery
Delivery Pile Capacity	510mm (20.08")
Registration System	Push side lay
Number of Rollers	Ink rollers : 16 (form rollers : 3) Water rollers : 5 (form roller : 1) (two sets, one for each unit)
Dampening System	Molleton
Gripper Margin	8mm (0.315")
Vertical Image Adjustment (Max.)	±20mm (±0.79")
Power	Mono-phase 208V 60Hz 12A, 220V 50Hz 11.5A
Wattage	2.5kW
Motor Wattage	Main drive : 1.5kW Pump : 550W
Dimensions (L × W × H)	2,200 × 965 × 1,560mm (86.61 × 37.99 × 61.42")
Net Weight	1,260kg (2,780 lbs.)

※ Design and specifications are subject to change without notice.

## 1-2 Roller Arrangement

### 1) List of Roller Pressure

Unit : mm

This list gives the marks that indicate the checking place and the required nip width (roller pressure) shown in the illustration.

Mark	◀	◀ A	◀ B	◀ C	◀ D
Nip width (mm)	Parallel pressure	1.5 ~ 2.0	2.0 ~ 2.5	2.5 ~ 3.0	3.0 ~ 3.5

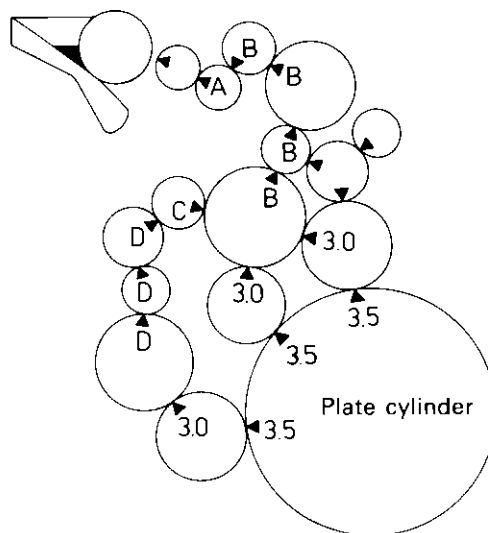

### 2) Roller Size and Rubber Hardness

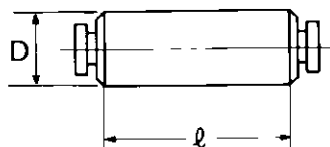
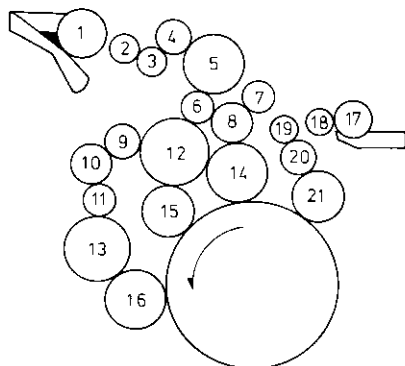

No.	Name	Outer diameter (D) mm (Inch)	Effective length (ℓ) mm (Inch)	JIS rubber hardness	Part number
1	Ink fountain roller	50 (1.969")	345 (13.58")	Steel	5340 51 031-3* <sup>1</sup> 5340 51 831-1* <sup>2</sup>
2	Ink ductor roller	31 (1.220")	333 (13.11")	25°	5340 51 140
3	Ink first roller	28.5 (1.122")	333 (13.11")	Rilsan	5322 51 310
4	Ink distributor roller	34 (1.339")	335 (13.19")	35°	5340 51 550
5	Ink rider oscillating roller	63 (2.480")	346 (13.62")	Rilsan	5322 51 610-1
6	Ink distributor roller	34 (1.339")	335 (13.19")	35°	5340 51 550
7	Ink distributor roller	34 (1.339")	327 (12.87")	35°	5340 51 560-1
8	Ink distributor roller	40 (1.575")	333 (13.11")	Rilsan	5340 51 510-1
9	Ink distributor roller	34 (1.339")	335 (13.19")	35°	5340 51 550
10	Ink distributor roller	40 (1.575")	333 (13.11")	Rilsan	5340 51 510-1
11	Ink distributor roller	34 (1.339")	335 (13.19")	35°	5340 51 550
12	Ink oscillating roller	69.16 (2.723")	340 (13.39")	Rilsan	5322 51 410-1
13	Ink oscillating roller	69.16 (2.723")	340 (13.39")	Rilsan	5322 51 410-1
14	Ink first form roller	61.5 (2.421")	335 (13.19")	30°	5340 51 700
15	Ink second form roller	56 (2.205")	335 (13.19")	30°	5322 51 700
16	Ink third form roller	65 (2.559")	335 (13.19")	30°	5322 51 810
17	Water fountain roller	40 (1.575")	355 (13.98")	Stainless	5340 53 160-3
18	Water ductor roller	26 (1.024")	346 (13.62")	32°	5340 53 170-1
19	Water distributor roller	26 (1.024")	346 (13.62")	32°	5340 53 170-1
20	Water oscillating roller	42 (1.654")	355 (13.98")	Stainless	5322 53 411-2
21	Water form roller	50 (1.969")	348 (13.70")	32°	5322 53 350-1

\*1 : When the ink feed volume control is done with the lever.

\*2 : When the ink feed volume control is done with the dial.

### 1-3 Cylinder Packing and Printing Starting Line

The cylinder packing (plate and blanket thickness when printing) for both the first and second units is as shown in the illustration.

When printing with the maximum printing area of 330 × 438 mm, the image should be exposed 23 mm down for the leading edge side (the printing starting line). (Please see the illustration.)

Note) When using a blanket with a different thickness, please contact your service technician.

Unit : mm

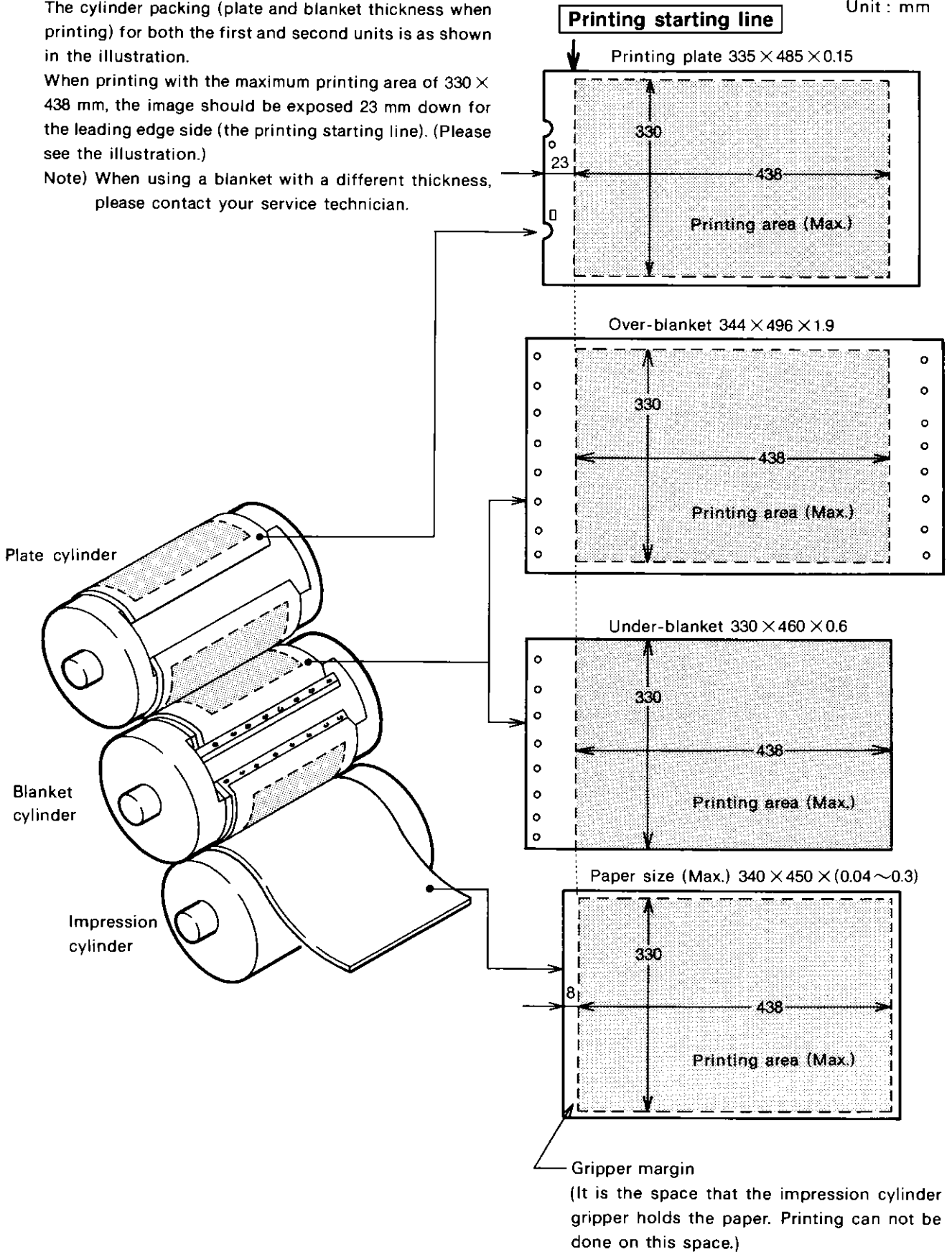

# Chapter

# 2

# Name and Function of Each Part

## Illustrated Contents

**OPS**

*Operation Side*

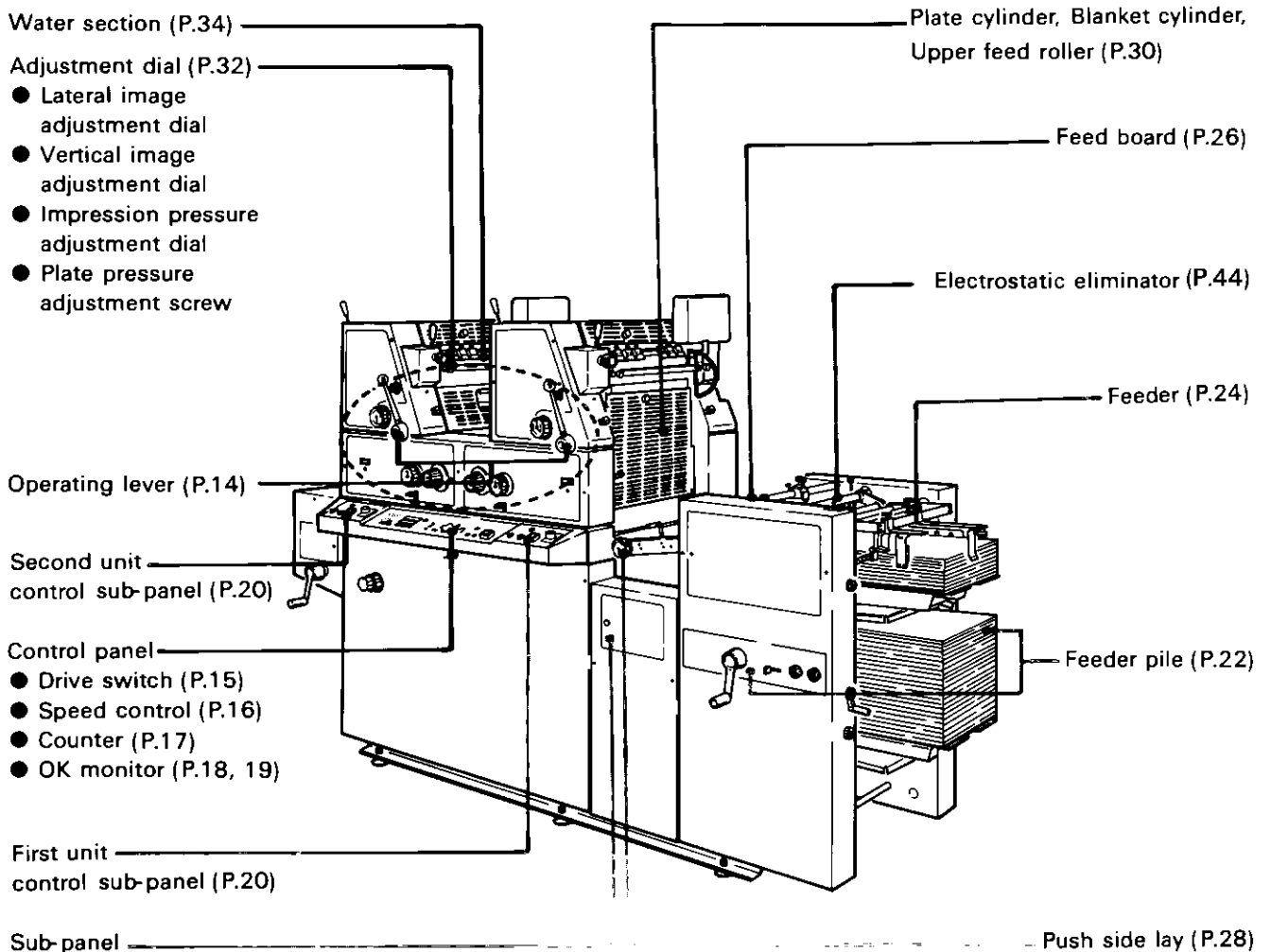

**NOPS**  
*Non Operation Side*

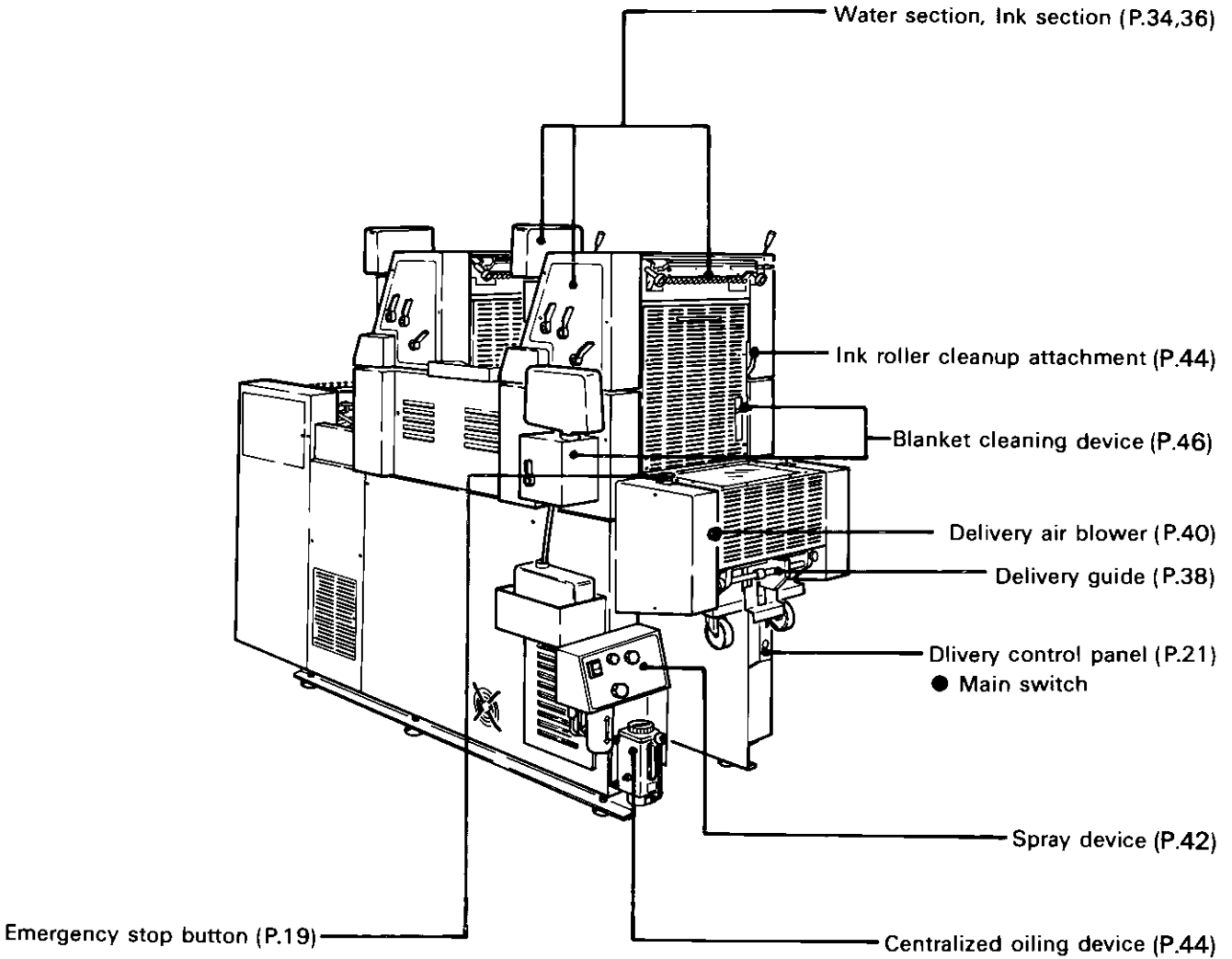



## 2-1 Operating Lever

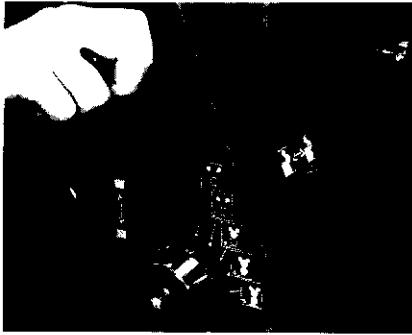

### A. Operating Lever

By using the lever the dampening, the inking, and the transferring of the image and paper feed and printing can be controlled.

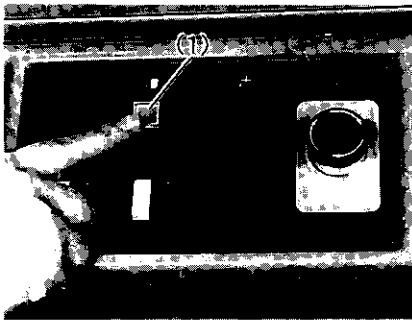

(Reference)

When pushing the printing button (1) ON (control sub-panel) for both the first and the second units, when shifting either lever, the other lever automatically follows the movement of the lever being shifted.

### The operating lever and the printing process

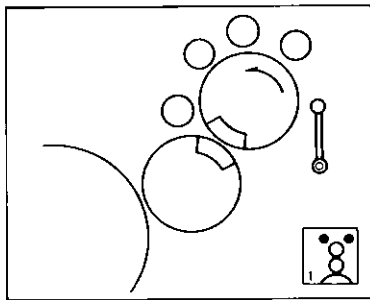

1) Both the ink and the water form rollers are released from the plate surface.

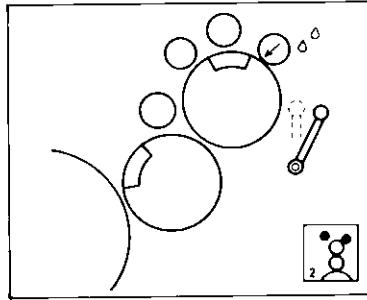

2) The water form roller comes in contact with the plate surface.

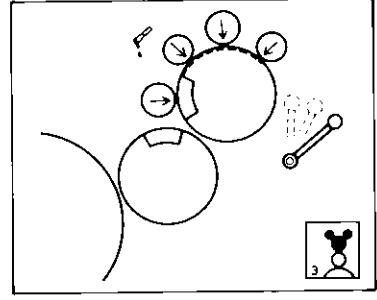

3) The ink form roller comes in contact with the plate surface. The pump starts.

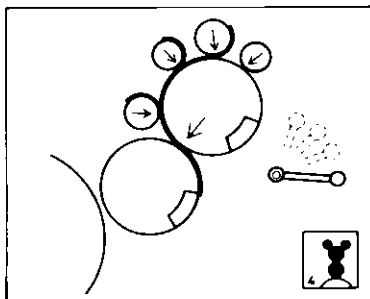

4) The plate cylinder and the blanket cylinder come in contact with, and the image is transferred onto the blanket.

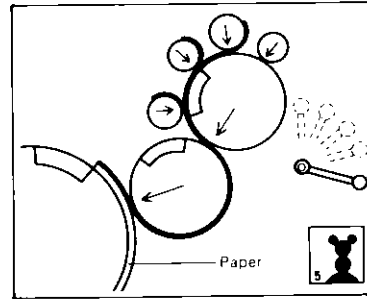

5) The paper feed starts and the printing starts. When stopping the paper feed, the plate cylinder, the blanket cylinder and the impression cylinder will automatically separate.

## 2-2 Control Panel

### 1) Drive Switch

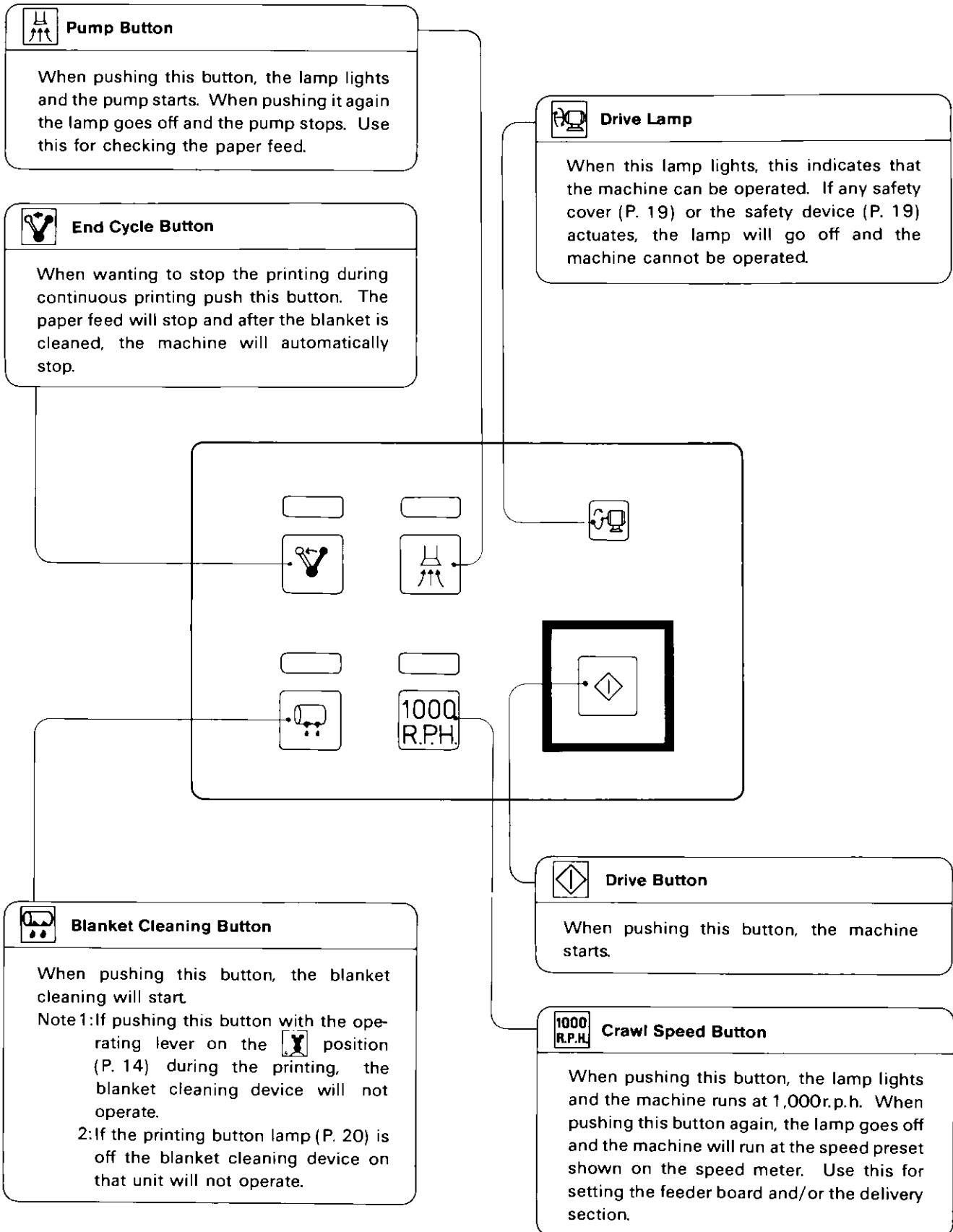

## 2) Speed Control

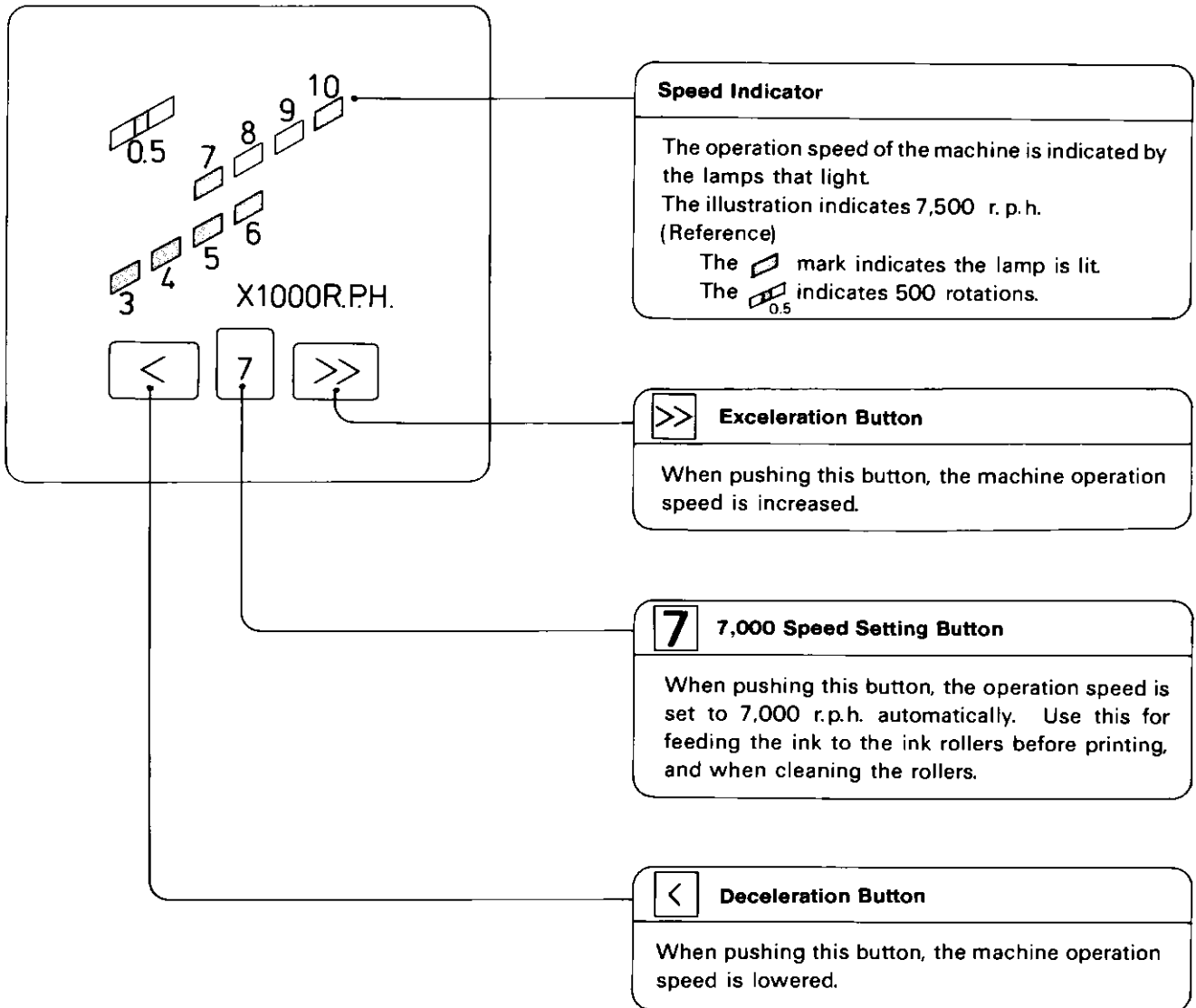



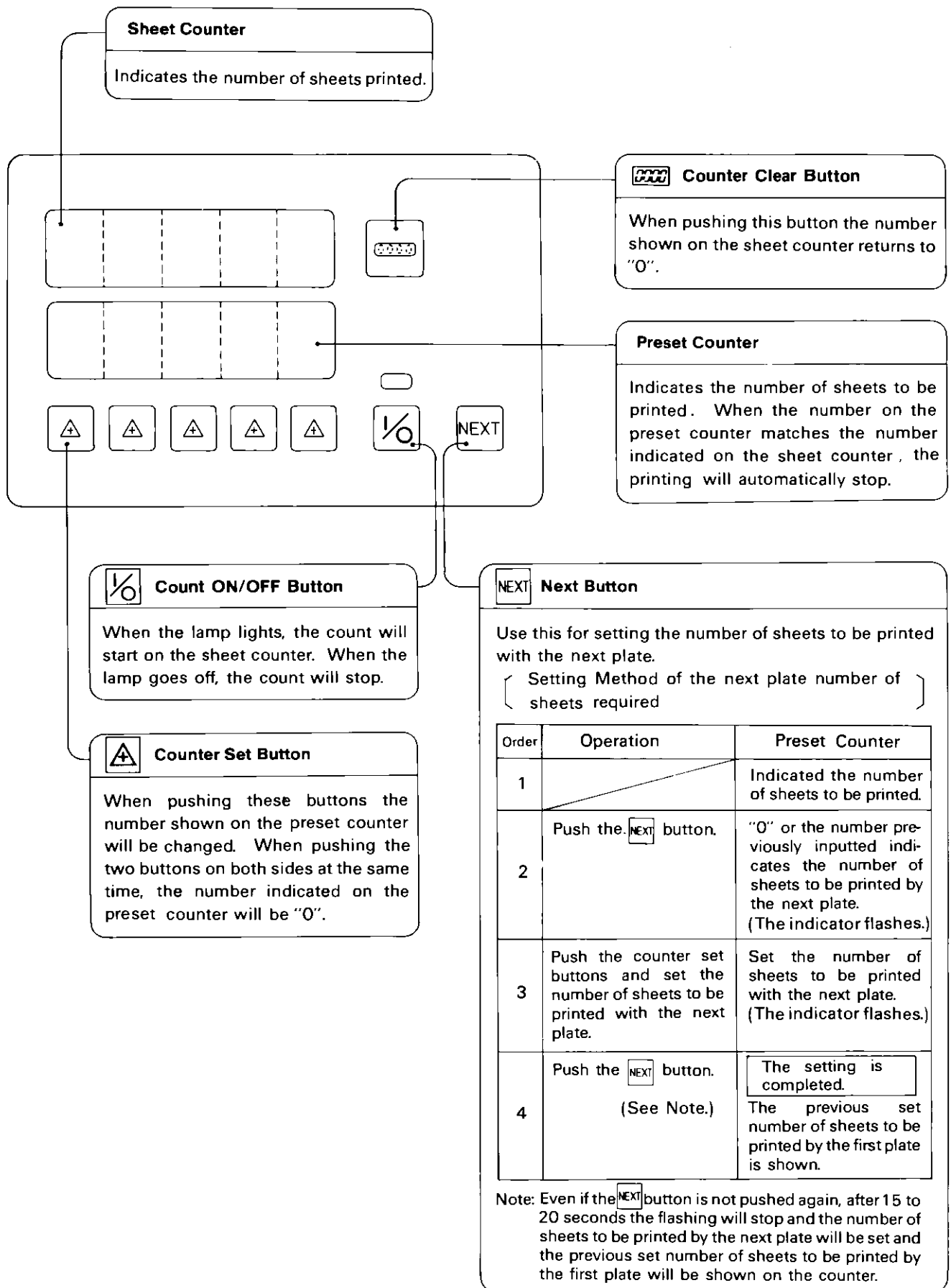



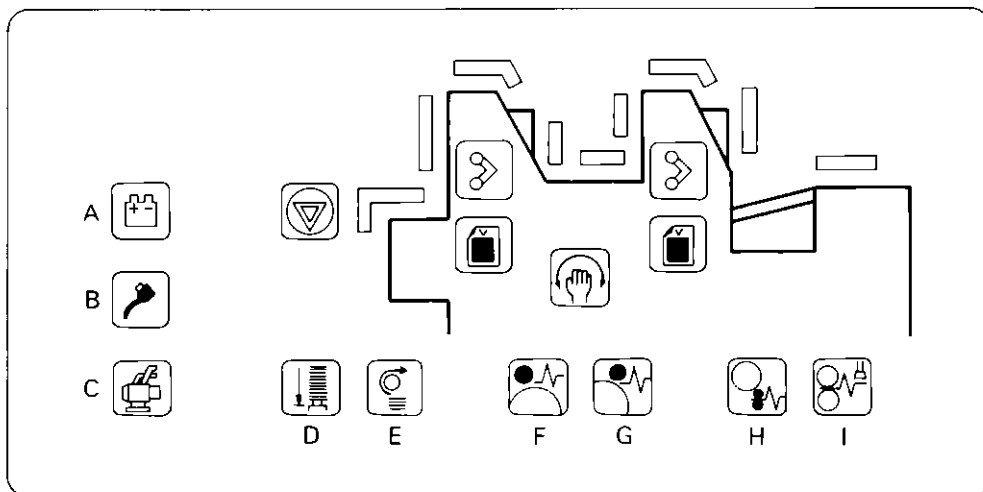

3) Counter



#### 4) OK Monitor 1



- A.**  **Battery Replacement Lamp**  
 When the voltage of the battery that powers the memory storage in the micro computer drops, the lamp lights so please contact a service technician.
- B.**  **Lubrication Warning Lamp**  
 When it is time for periodic lubrication of all of the machine parts, this lamp lights. (See P. 21)
- C.**  **Pump Warning Lamp**  
 When the pump filter needs to be cleaned, this lamp lights. (See P. 21)
- D.**  **Delivery Pile Lower Limit Detector Lamp**  
 When the delivery pile table dolly is full, the paper feed stops and this lamp lights.
- E.**  **Delivery Jam Detector Lamp**  
 When a delivery jam occurs, the machine will stop and this lamp lights. At the same time, a buzzer sounds to inform the operator that a delivery jam has occurred.  
 After removing the jammed sheet, when pushing the drive button, the lamp will go off.
- F.**  **Second Unit Blanket Jam Detector Lamp**  
 When a sheet of paper is jammed on the second unit blanket, the machine will stop and this lamp lights. At the same time, a buzzer sounds to inform the operator that a blanket jam has occurred.  
 After removing the jammed sheet, when pushing the drive button, the lamp will go off.
- G.**  **First Unit Blanket Jam Detector Lamp**  
 This is the lamp for the first unit blanket jam detector.
- H.**  **Feed Jam Detector Lamp**  
 If the paper feed trouble occurs, this lamp indicates where the paper feed trouble is.  
 ● Infeed jam . . . . This lamp lights.  
 This detects when the paper feed trouble occurs on the feeder board with the feed jam detector ON/OFF switch ON.  
 ● Paper feed drum sensor jam . . . . This lamp flickers.  
 This detects when a sheet of paper is on the paper feed drum sensor while a sheet of paper drops onto the sensor and the machine makes one rotation with the feed jam detector ON/OFF switch ON.
- I.**  **Paper Feed Delayed Timing Detector Lamp**  
 If a sheet of paper fed is delayed on the feeder board, the paper feed will stop and this lamp lights. At the same time, the stopper prevents the delayed sheet of paper from being fed into the paper feed drum, and a buzzer sounds to inform the operator that the sheet is delayed. Remove the sheet of paper on the feeder board, and when shifting the feed lever ON, the lamp will go off.

5) OK Monitor 2 (Safety Cover, Safety Device)

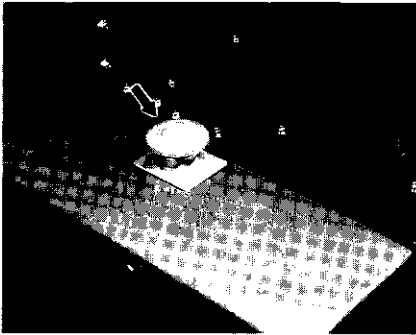

**Emergency Stop Button**

When pushing this button, it will lock to stop the machine. When turning the button in the direction of the arrow, the lock will be released and the lamp goes off so the machine can be run.

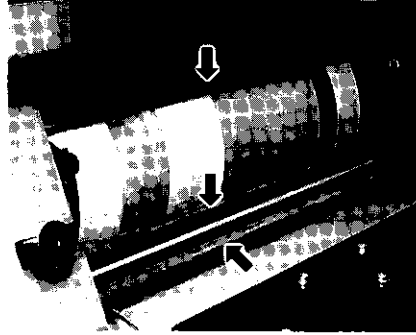

**Second Unit Safety Bar**



**First Unit Safety Bar**

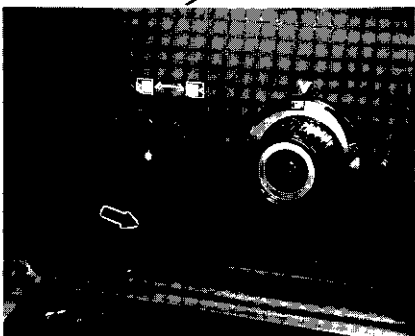
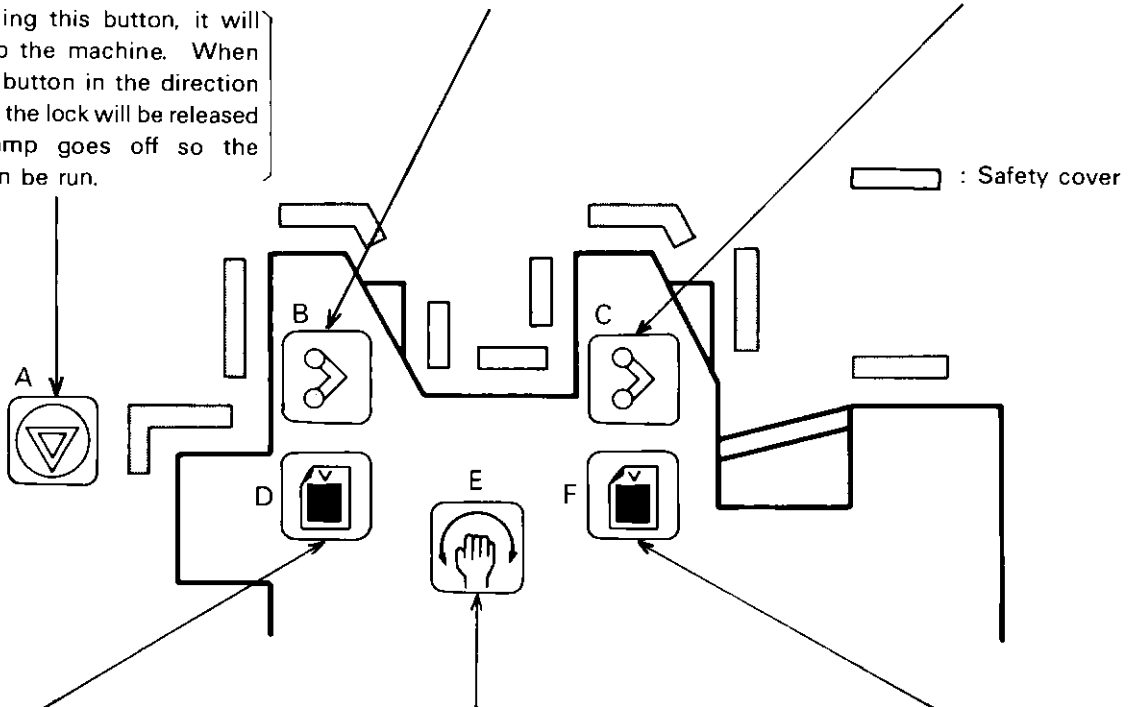

**Second Unit Vertical Image Adjustment Clutch Lever**

When doing the vertical image adjustment on the second unit, a safety device will actuate so the machine cannot be run.

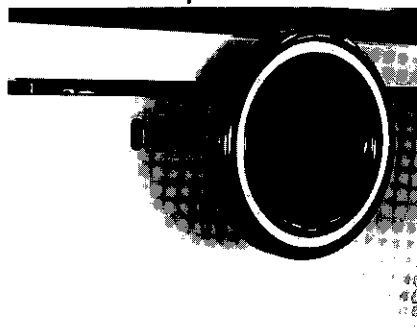

**Handwheel Mounting Door**

When mounting the handwheel to manually rotate the machine a safety device will actuate so the machine cannot be run.



**First Unit Vertical Image Adjustment Clutch Lever**

When doing the vertical image adjustment on the first unit, a safety device will actuate so the machine cannot be run.

When opening the safety cover, the lamp will light and the machine will stop to assure the safety.  
And when a safety device from A to F operates, inching also can not be done.

### 2-3 Control Sub-Panel

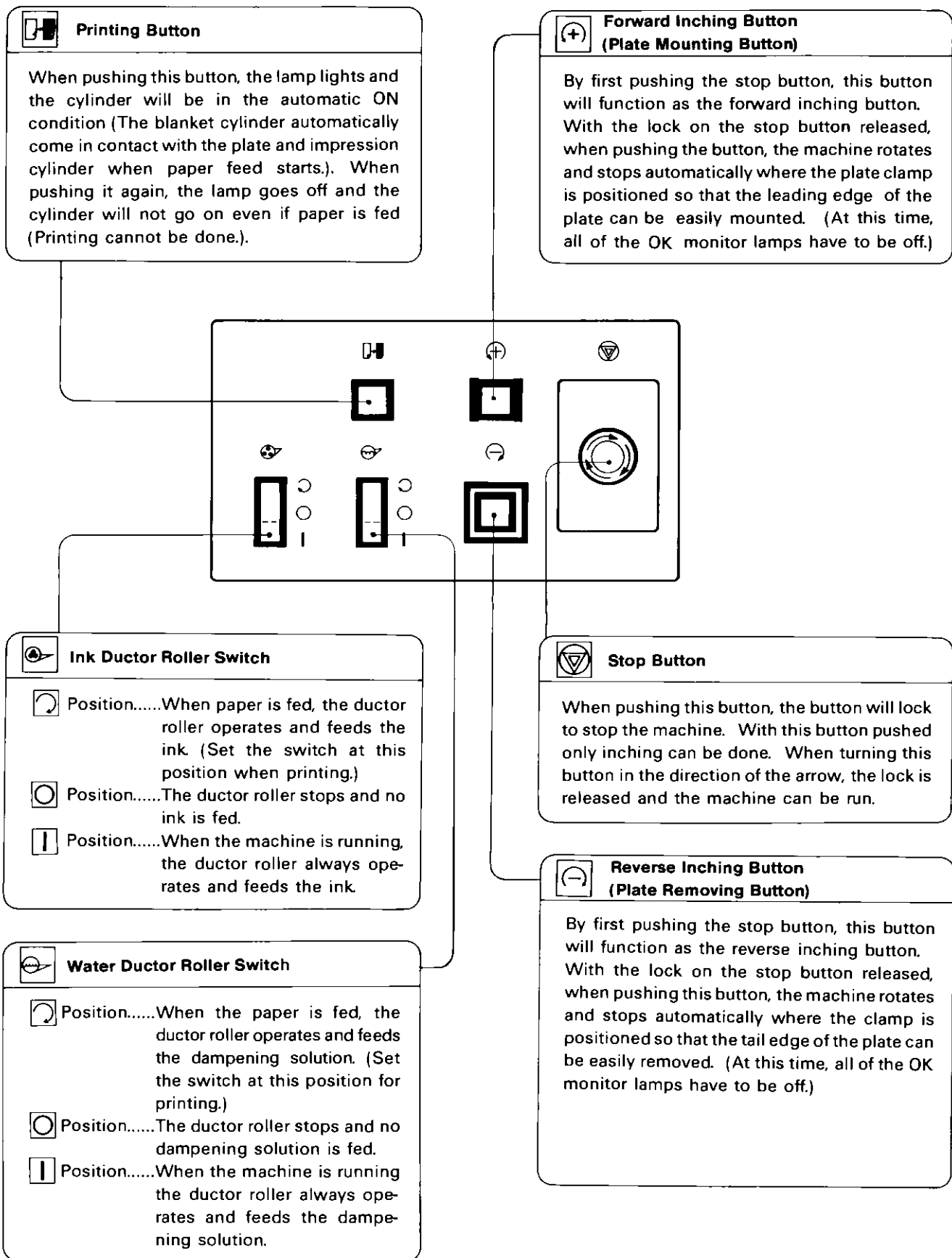

2-4 Sub-Panel

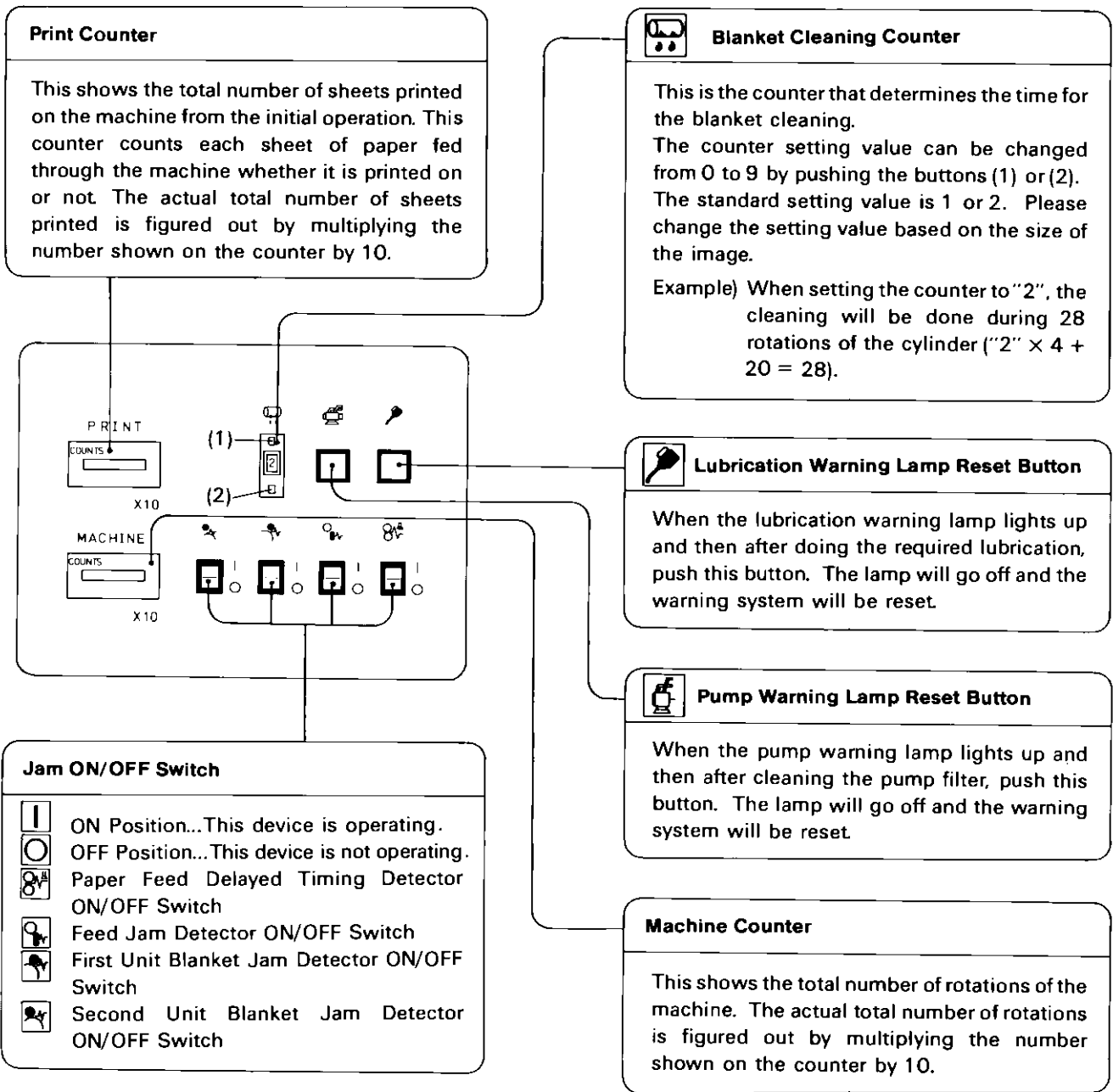

2-5 Delivery Control Panel

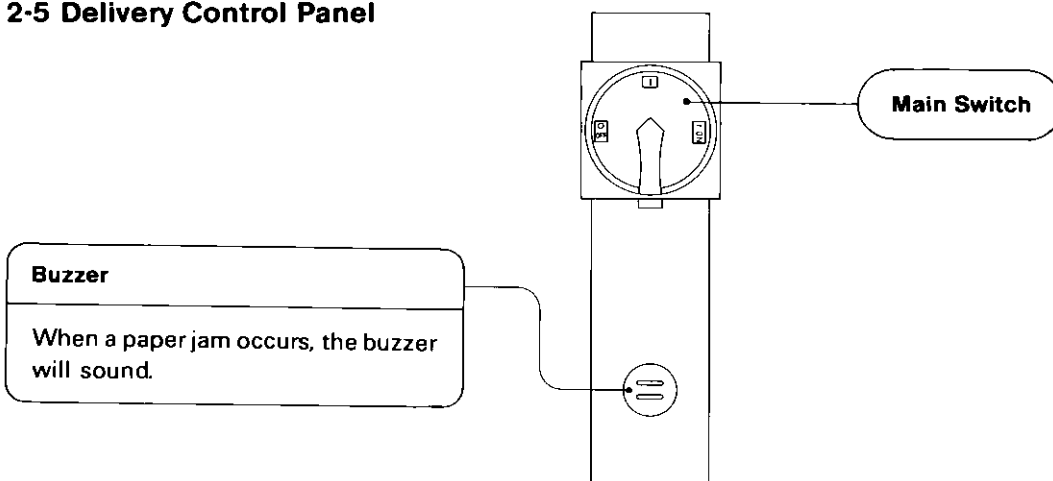



## 2-6 Paper Feed Section

### 1) Feeder Pile

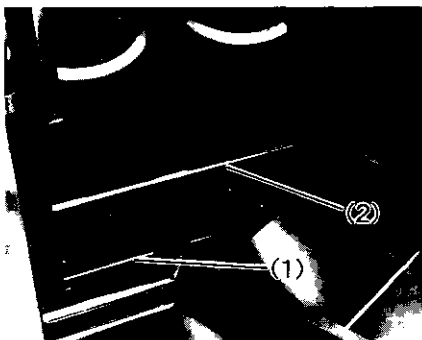
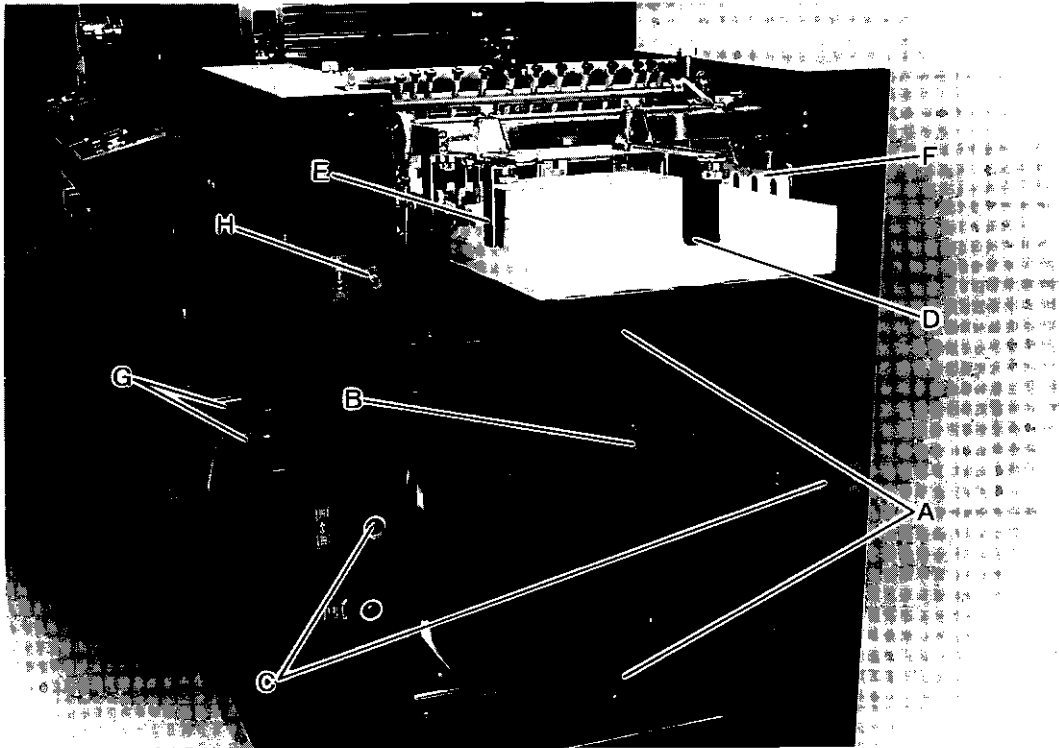

#### A. Paper Pile Table (pre-pile)

Set the paper feed table on the stay (1) and the stay (2).

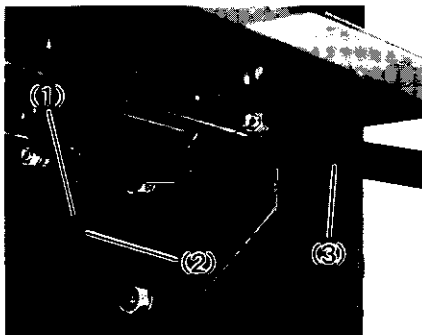

#### (Reference) Mounting and Removing

The pins (1) engage with the grooves (A) on the paper feed table and when the paper feed table is elevated, the latch (2) locks the pin (1) in place automatically. To remove the table, lift the lever (3) so that the lock will be released.

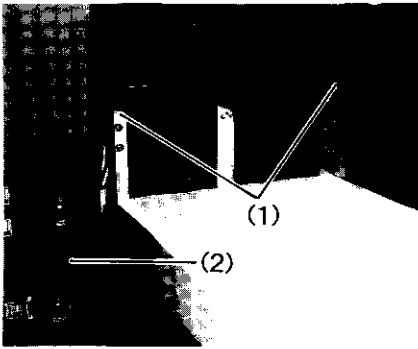

**B. Vertical Guide (1)**

When piling the paper, pile it straight following the guide (1).

**C. Vertical Guide Handle (2)**

This handle is used to set the vertical guides at both sides of the pile.



Direction . . . Moves the vertical guide toward the pile.



Direction . . . Moves the vertical guide away from the pile.

**D. Back Guide (1)**

This guide is used to guide the back of the paper pile.

**E. Side Guide (2)**

This guide is used to guide the side of the paper pile.

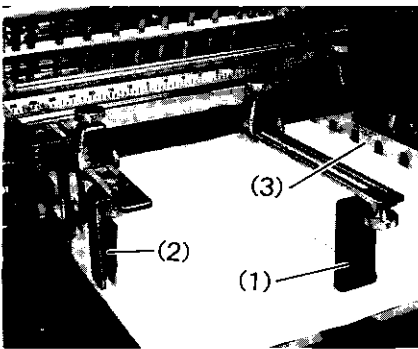

**F. Micro Side Guide (3)**

This is used to make micro adjustments of the lateral position of the paper pile. When turning the adjustment knob (4) in the ← direction, the micro side guide (3) moves toward the operation side.

The maximum movement is 5mm and when turning the knob (4) one complete turn, the micro side guide (3) will move 1.3mm.

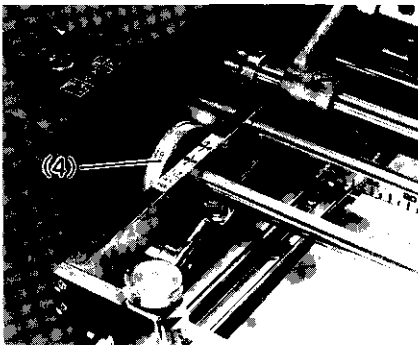

**G. Paper Feed Table Elevating/Lowering Device**

**Crank Handle (1)**



Direction . . . The paper pile table will be elevated.



Direction . . . The paper pile table will be lowered.

**Release Lever (2)**



Position . . . During the machine operation, the paper pile table will be elevated automatically.



Position . . . Stops the paper pile table elevating automatically. To manually lower the paper pile table, set the release lever at this position and turn the crank handle (1). At the  position, the table cannot be lowered.

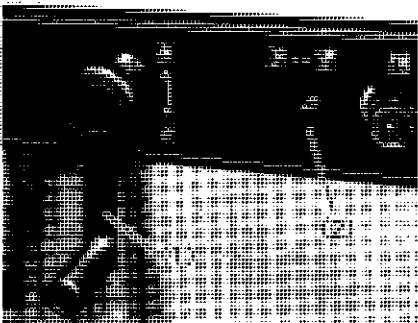

**H. Height Control Knob**

This is used to set the height of the paper pile during printing.



Direction . . . The paper pile height will be raised.



Direction . . . The paper pile height will be lowered.

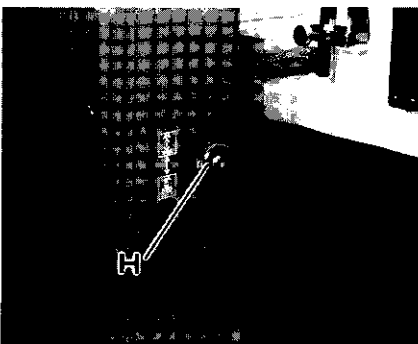

## 2) Feeder

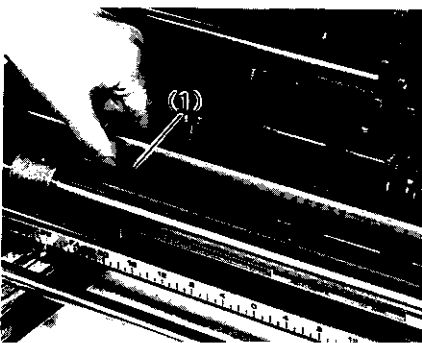
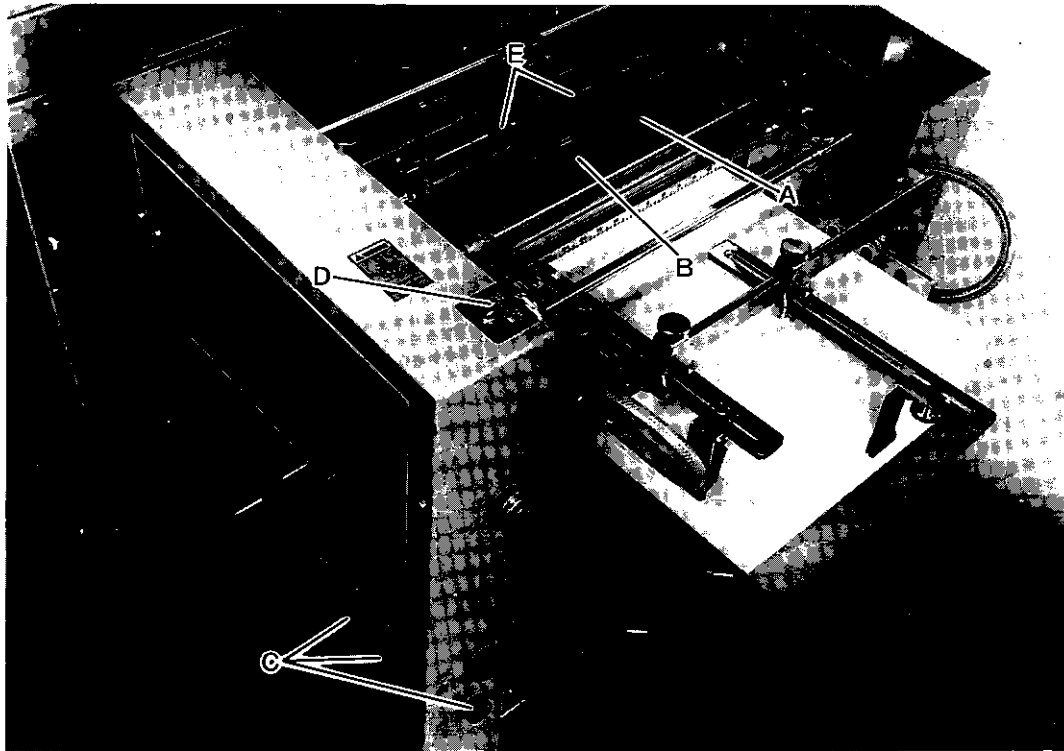

### A. Suction Feet

They pick up the paper and feed it to the feeder board.  
When pulling up the knob (1), the vacuum will be cut off.

(Reference) Rubber Sucker

When printing on thick paper (When strong vacuum is needed),  
mount them on the suction feet.

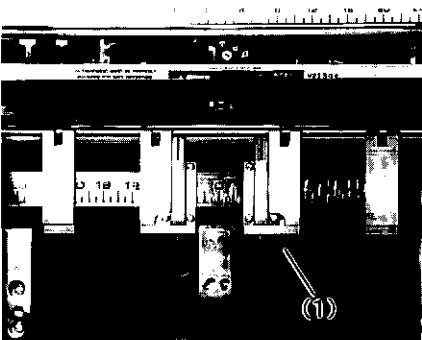
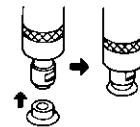

### B. Sheet Separator

This prevents double sheet feed. Usually four are used. Loosen the  
screw (1) and then do the position adjustment.

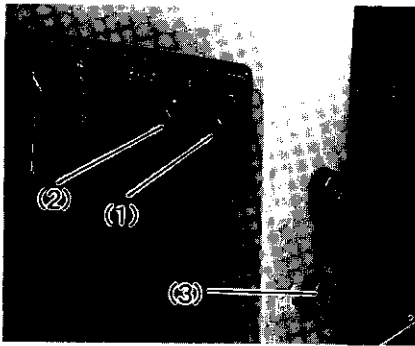

**C. Vacuum, Blower Control Knob**



Vacuum Control Knob (1)

When turning the knob in the clockwise direction, the suction feet vacuum will increase.



Blower Control Knob (2)

When turning the knob in the clockwise direction, the blower volume from the blower nozzle (4) will increase.



Back Blower Control Knob (3)

When turning the knob in the clockwise direction, the blower volume from the blower nozzle (5) will increase.

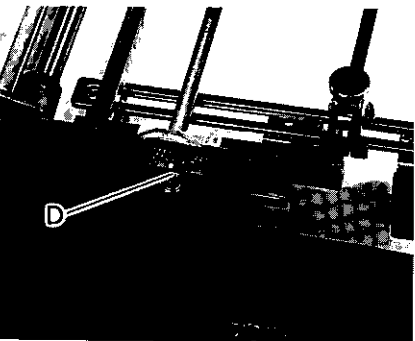

Feeder Side

**D. Feed Lever**

This lever controls the ON/OFF of the paper feed.



Position ...The paper feed starts.



Position ...The paper feed stops.

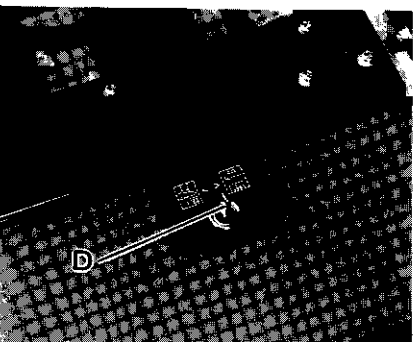

Delivery Side

(Reference)

A feed lever is also mounted at the delivery side, therefore the paper feed can be started or stopped from the delivery side.

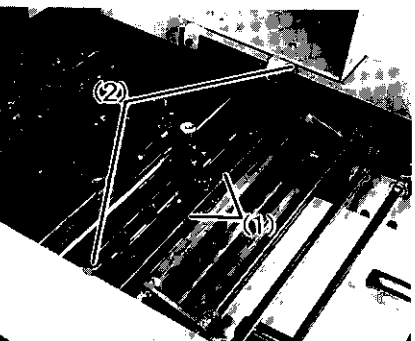

**E. Pull Out Roller**

The pull out roller (1) feeds the sheet of paper that is fed by the suction feet and to the feeder board. The roller pressure is adjusted by turning the knobs (2).

### 3) Double Sheet Detector, Feeder Board

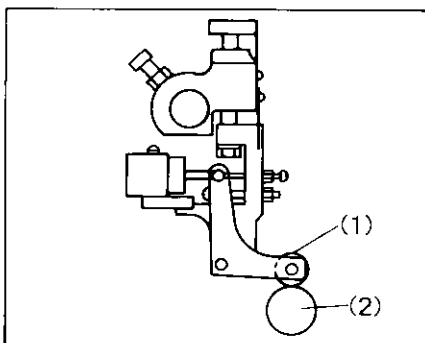
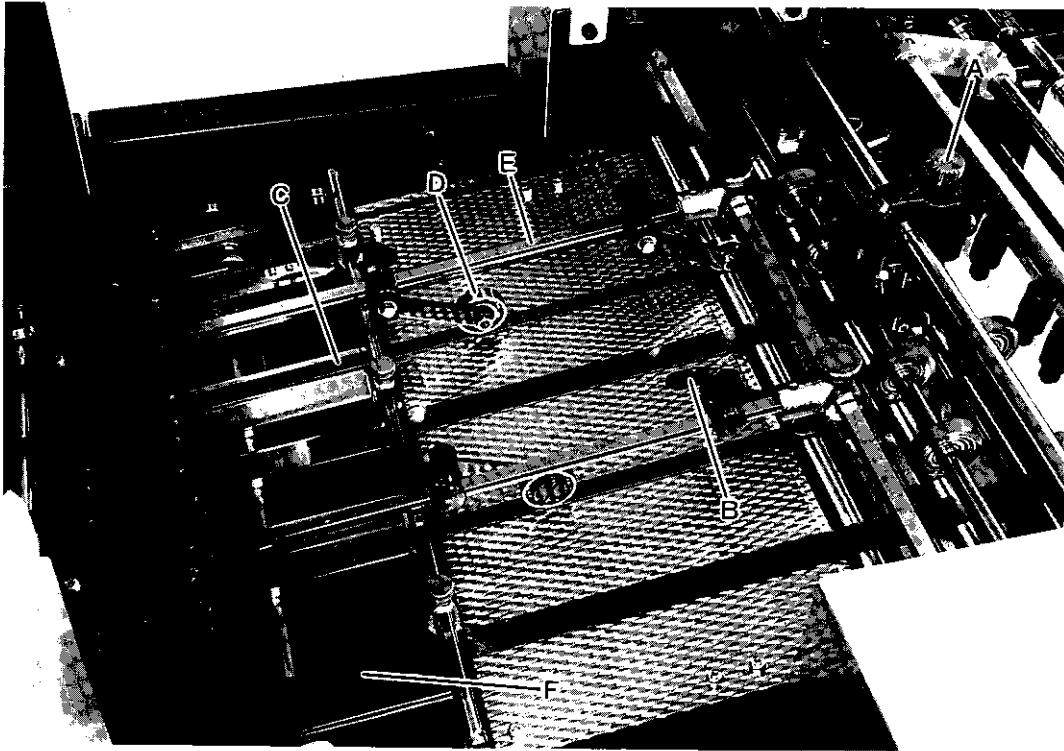

#### A. Double Sheet Detector

This detects any double sheets fed, by the clearance between the detector roller (1) and the feed roller (2), and automatically opens the shutter (3) and the double sheets are ejected into the paper tray.

Adjust the clearance between the detector roller (1) and the feed roller (2) by turning the knob (5). When turning it in the clockwise direction, the clearance will be increased.

Guide Roller (6) is the one that ejects the double sheets into the paper tray smoothly.

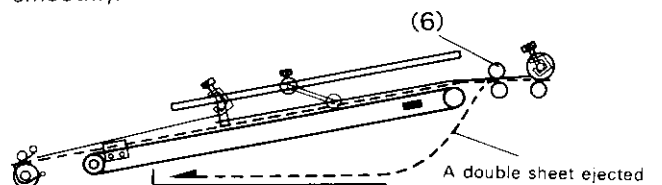
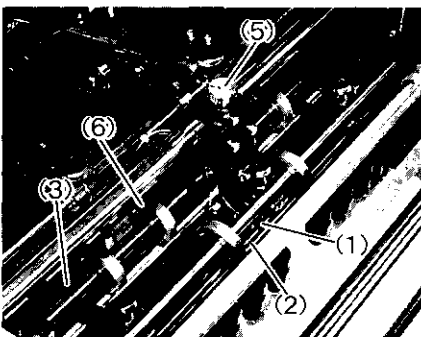

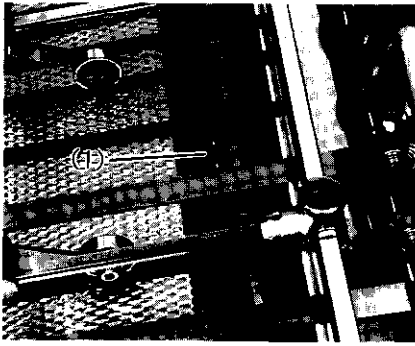

**B. Photo Sensor (1)**

This sensor detects the sheet of paper passing through and sends the count signal to the counter. This sensor also detects any delayed timing of a sheet.

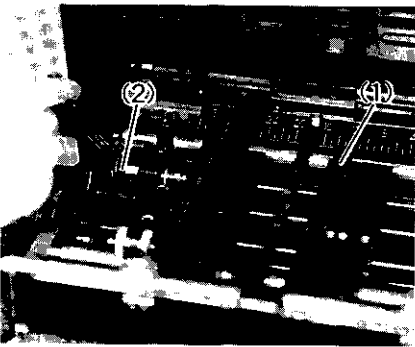

**C. Board Tape**

These tapes deliver the paper that was fed by the pullout roller to the paper stop finger (P. 31).

When moving the board tape (1), first loosen the board tape tensioner lock nut (2), then move it.

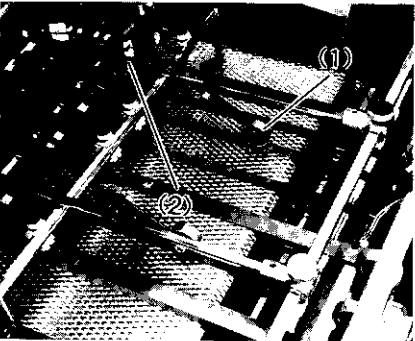

**D. Skid Roller (1)**

It is set on the board tape and prevents any backlash when the sheet of paper contacts the paper stop finger.

**E. Skid Roller Mounting Bar (2)**

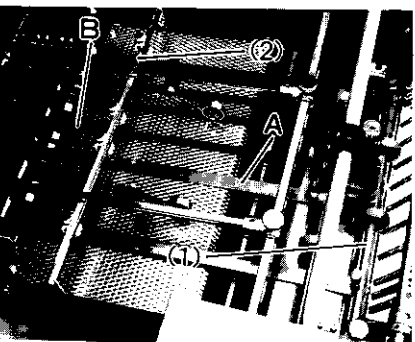

**F. Retainer**

This guides the paper on the feeder board up to the paper stop finger without allowing the sheet to curl or float up from the feeder board.

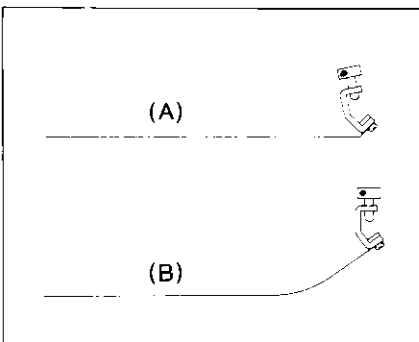

**(Reference)**

There are two different retainers. The retainer (A) has a square edge. The retainer (B) has a rounded edge.

Mount the retainer (A) on the pullout roller shaft (1).

There are two types of retainers that are mounted on the feeder board shaft (2) (Retainer B), one for thin paper and one for thick paper. The retainer for the thin paper is used when feeding paper with a thickness of less than 0.1 mm.

#### 4) Push Side Lay

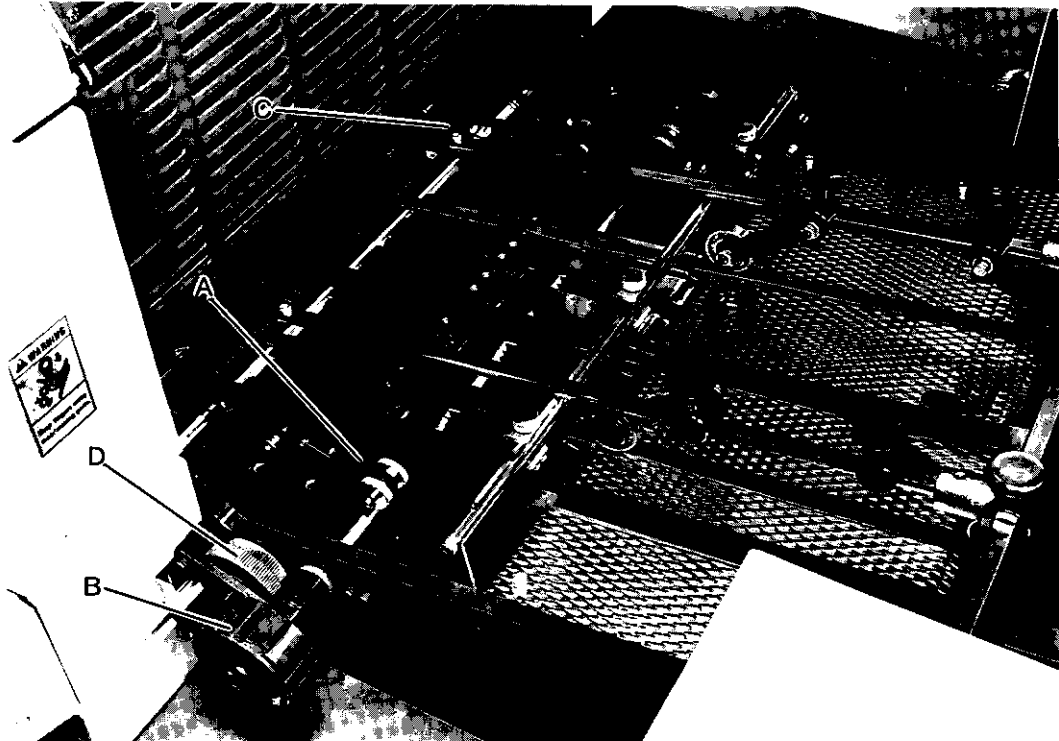

##### A. Push Side Lay

It aligns the lateral position of the sheet.

Loosen the lock nut (2) and adjust by turning the screw (3) so the jogger guide (1) is parallel to the sheet of paper.

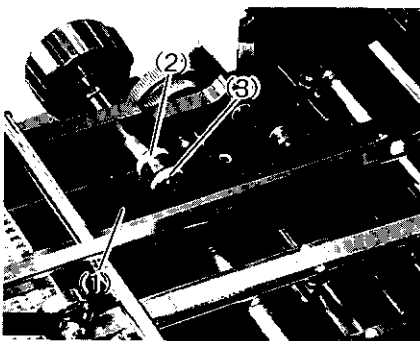

##### B. Push Side Lay Adjustment Dial

When turning the dial (1) in the clockwise direction, the lateral position of the sheet moves toward the non-operation side. One complete turn of the dial moves the sheet 2mm. Moving the long indicator by one scale moves the sheet by 0.2mm. The maximum movement is  $\pm 2$ mm. If a movement of over  $\pm 2$ mm is required, loosen the fixing screw (2) and move the push side lay (3).

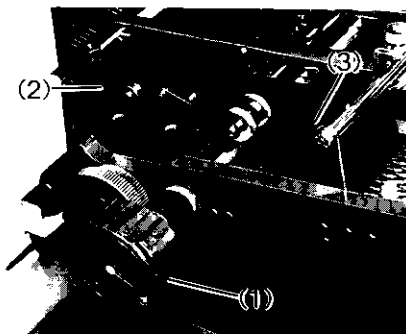

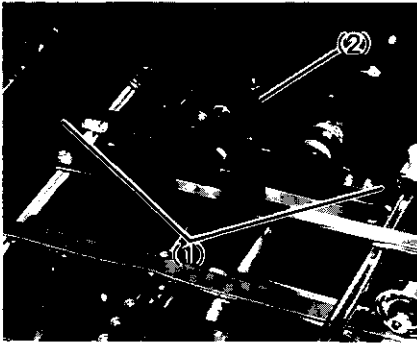

**C. Flat Spring**

The flat spring (1) pushes the paper against the guide and assures that the lateral registration of the sheet is uniform.

When changing the position of the flat spring (1) greatly, loosen the screw (2) and change the position of the flat spring (1).

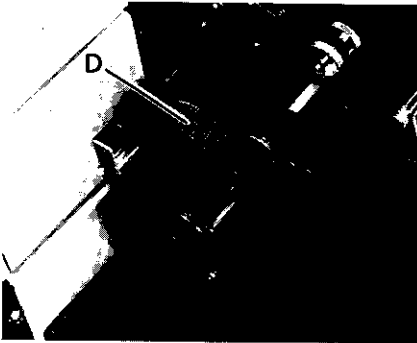

**D. Flat Spring Micro Adjustment Knob**

Use this when doing the micro adjustment of the flat spring lateral position.

**(Reference) Flat Spring**

There are two types of flat springs, one for thin paper and one for thick paper. The flat spring for thin paper is used for paper with a thickness of less than 0.1 mm.

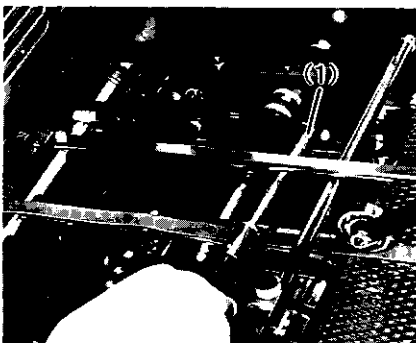
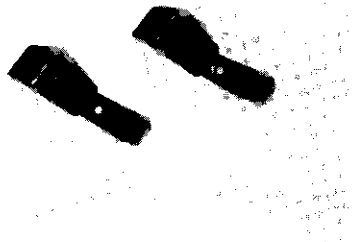

Loosen the fixing screw (1) to change the flat spring.

Also change the mounting position of the flat spring to match the paper size.



## 2-7 Printing Section

### 1) Plate Cylinder, Blanket Cylinder, and Upper Feed Roller

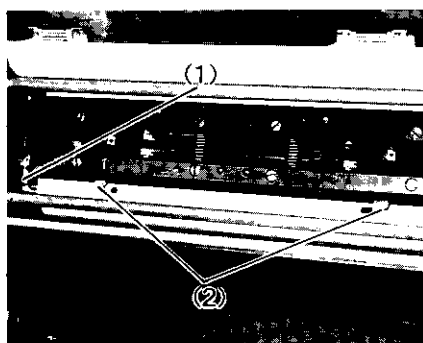
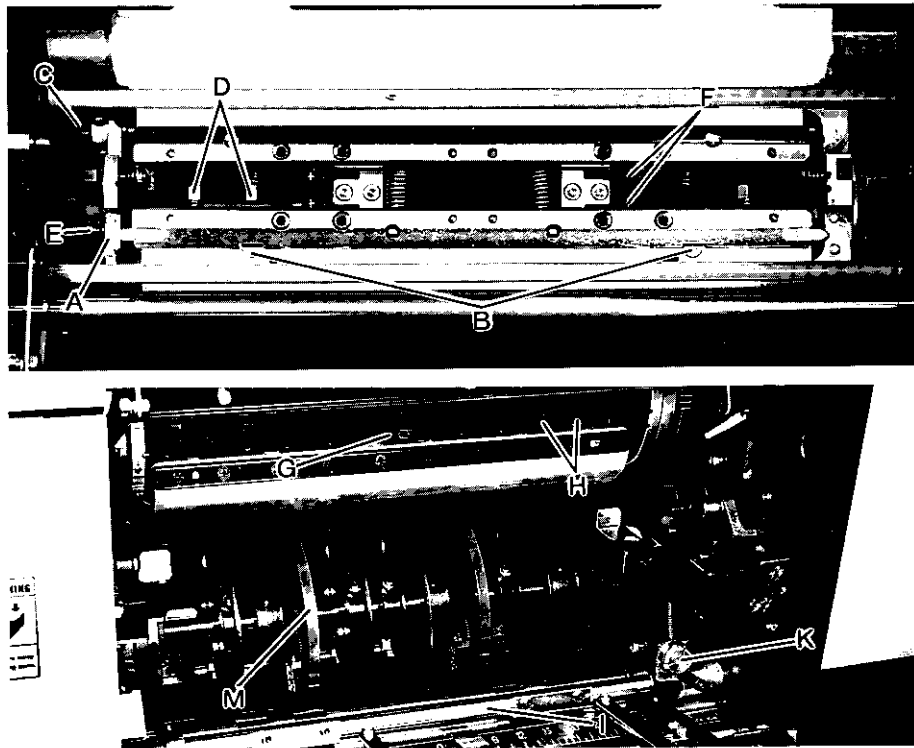

**A. Plate Clamp Positioning Scales (1)**

Use these scales when setting the clamp parallelly to the cylinder, or when doing the diagonal adjustment of the plate.

**B. Plate Positioning Pins (2)**

When mounting the plate, fit the U-shaped cuts on the leading edge of the plate on these pins exactly.

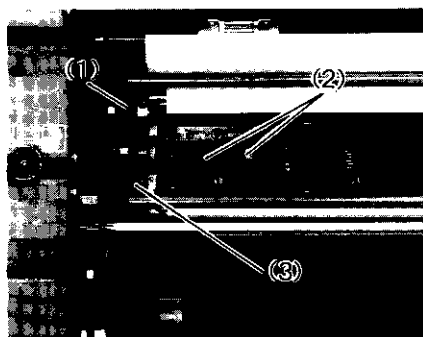

**C. Quick Tension Bolt (1)**

Using this bolt, the plate will be tensioned at the fixed position.

**D. Plate Tension Bolt (2)**

Screw in this bolt to tension the plate.

**E. Lateral Position Adjustment Bolt (3)**

Use this bolt to center the clamp laterally or to do the diagonal adjustment of the plate.

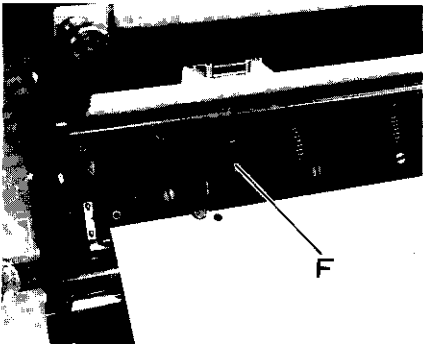

**F. Plate Clamp Bolt**

Turn this bolt to open or close the clamp. When the yellow mark is visible, the clamp is open, and when the red mark is visible, the clamp is closed.

Note) The clamp holding power has been adjusted to secure a 0.15mm thick plate. If the clamp holding power is weak or strong, please contact your local service technician.

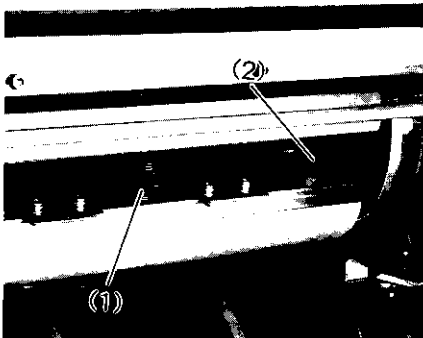

**G. Tensioning Knob (1)**

This is used to tension the blanket. When turning the knob in the clockwise direction, the blanket is tensioned.

**H. Tensioning Bolts (2)**

These two tensioning bolts on both the leading and tail edges are used to equally tension the both edges of the blanket.

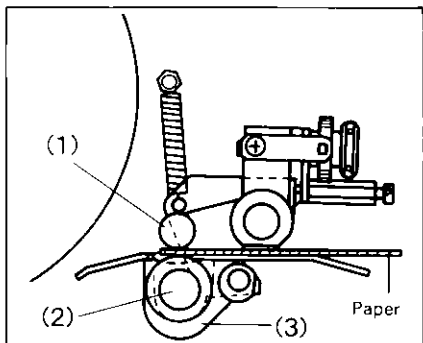

**I. Upper Feed Roller (1), Lower Feed Roller (2)**

These rollers feed the sheet of paper to the paper feed drum.

**J. Paper Stop Finger (3)**

The paper that is fed on the feeder board stops at the paper stop finger momentarily so it can be registered by the push side lay.

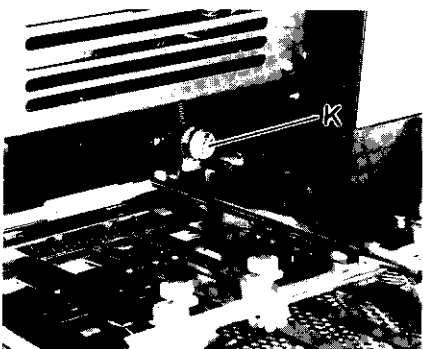

**K. Upper Feed Roller Pressure Adjustment Knob**

This knob is used to adjust the paper feed pressure of the upper feed roller. The standard pressure is when the upper feed roller rotates from 1-1/4 to 1-1/2 turns when it is in contact with the lower feed roller.

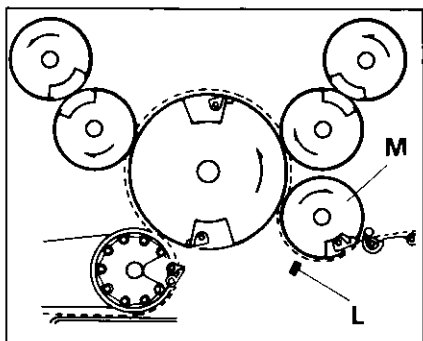

**L. Cylinder ON Sensor**

This sensor detects the paper and sends the signal of the ON/OFF of the blanket cylinder. This sensor also detects any feed jammed sheet.

**M. Paper Feed Drum**

This drum transfers the sheet of paper fed from the feeder board to the impression cylinder.

2) Lateral Image Adjustment, Vertical Image Adjustment, Impression Pressure Adjustment, Plate Pressure Adjustment Device

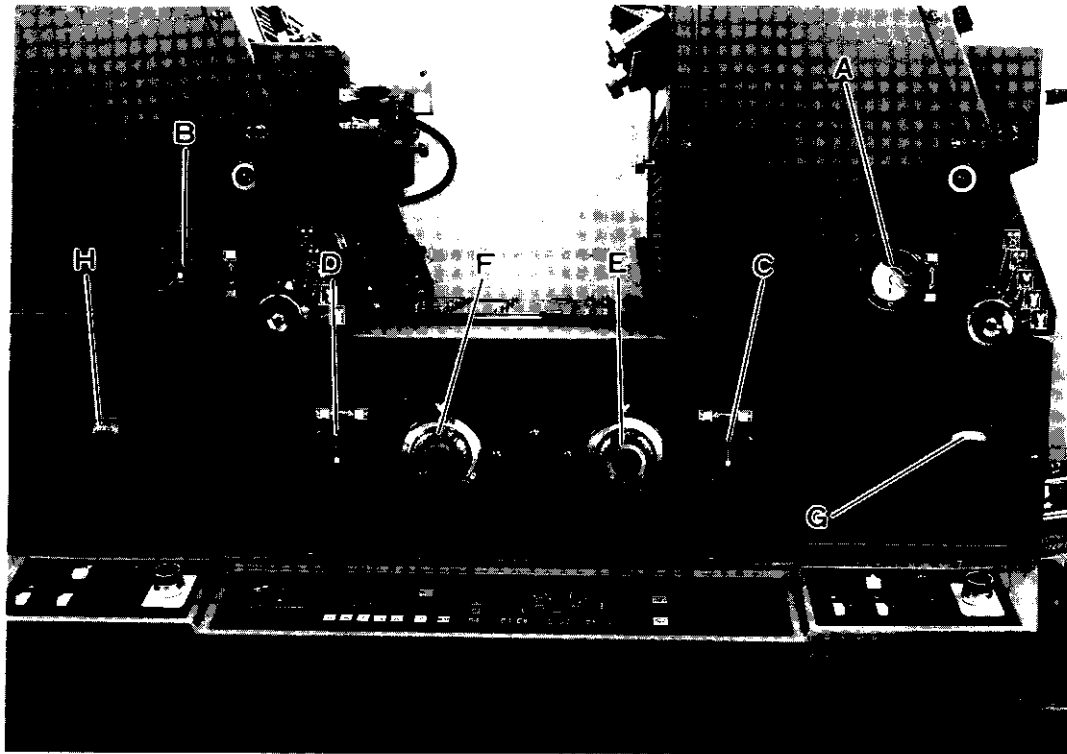

- A. Lateral Image Adjustment Dial (First Unit)
- B. Lateral Image Adjustment Dial (Second Unit)

..... When turning the dial, the plate cylinder moves to the left or the right. This is used for the lateral position adjustment of the image on the first and the second units.

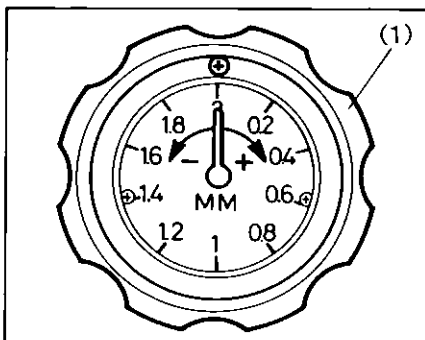

(Reference)

When turning the adjustment dial (1) in the clockwise direction, the image moves toward the operation side. Moving the long indicator one scale moves the image 0.2 mm. The maximum movement is  $\pm 2$  mm.

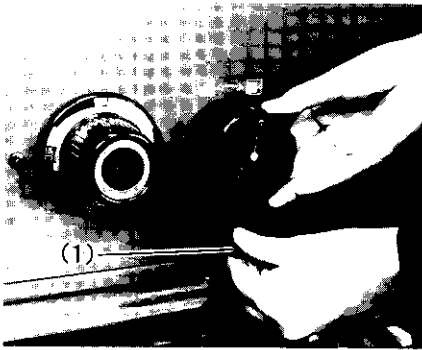

- C. Vertical Image Adjustment Dial (First Unit)
- D. Vertical Image Adjustment Dial (Second Unit)

..... Push in the vertical image adjustment dial with the clutch lever (1) pushed down and when releasing the lever(1), the vertical image adjustment dial is locked and the vertical image adjustment can be done.

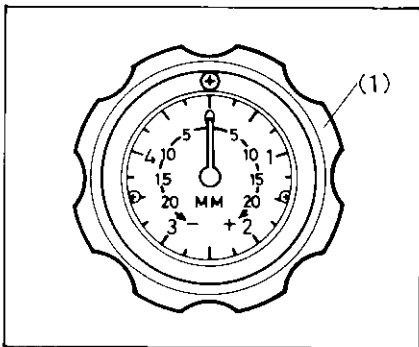

(Reference)

When turning the adjustment dial (1) in the clockwise direction, the image moves toward the leading edge.

Moving the long indicator one scale moves the image 0.5 mm. The maximum movement is  $\pm 20$ mm.

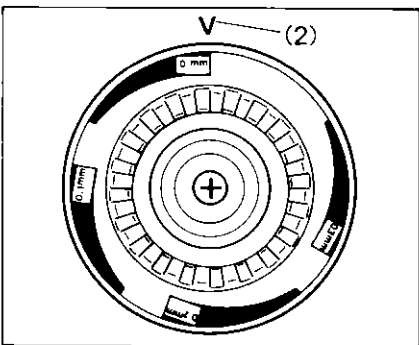

- E. Impression Pressure Adjustment Dial (First Unit)
- F. Impression Pressure Adjustment Dial (Second Unit)

..... Adjust the impression pressure by turning the dial. When aligning the value on the impression pressure adjustment dial with the indicator (2) depending on the paper thickness the proper impression pressure will be secured.

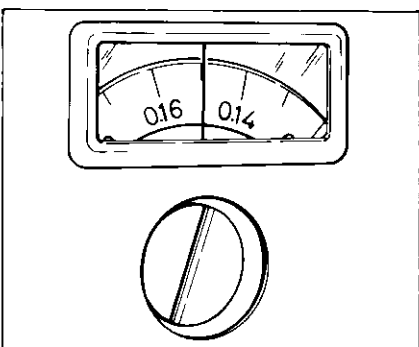

- G. Plate Pressure Adjustment Screw (First Unit)
- H. Plate Pressure Adjustment Screw (Second Unit)

..... Adjust the plate pressure by turning the screw. The scale shows the plate thicknesses. When aligning the plate thickness value on the scale indicator, the proper plate pressure is assured.

## 2-8 Water Section, Ink Section

### 1) Water Section, Ink Section 1

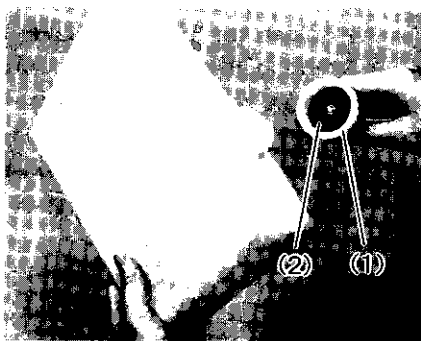

#### A. Dampening Solution Bottle

This is the container that holds the dampening solution. Add the designated volume of etching solution and gum solution depending on the type of plate to be used.

Note) On the inside of the bottle cap (1) there is a rubber packing (2). If the bottle is mounted without the packing, the dampening solution may leak out.

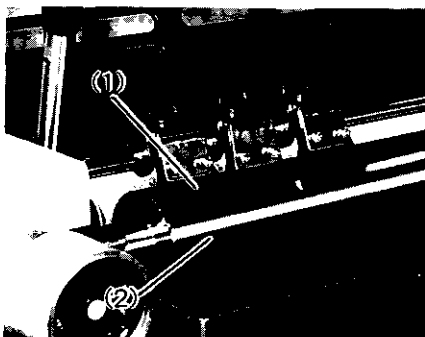

#### B. Water Control Wiper

To partially adjust the dampening solution feed volume, contact the water control wiper (1) to the water fountain roller (2).

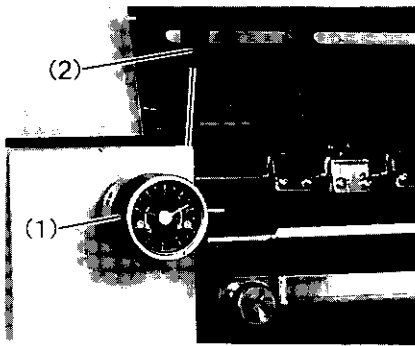

**C. Water Volume Control Dial (1)**

This dial is used to control the total feed volume of the dampening solution steplessly. The dampening solution feed volume is indicated on the scale. Turning the dial toward a larger number increases the dampening solution feed volume.

**D. Water Fountain Roller Lever (2)**

This lever is used for manually turning the water fountain roller.



**E. Water Form Roller Pressure Adjustment Knob**

This knob is used to adjust the pressure between the water form roller and the plate surface.

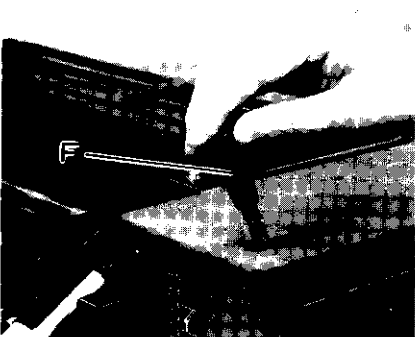

**F. Ink Fountain Roller Lever**

This lever is used for manually turning the ink fountain roller.

2) Water Section, Ink Section **2**

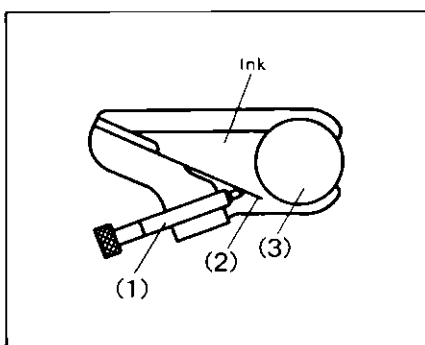
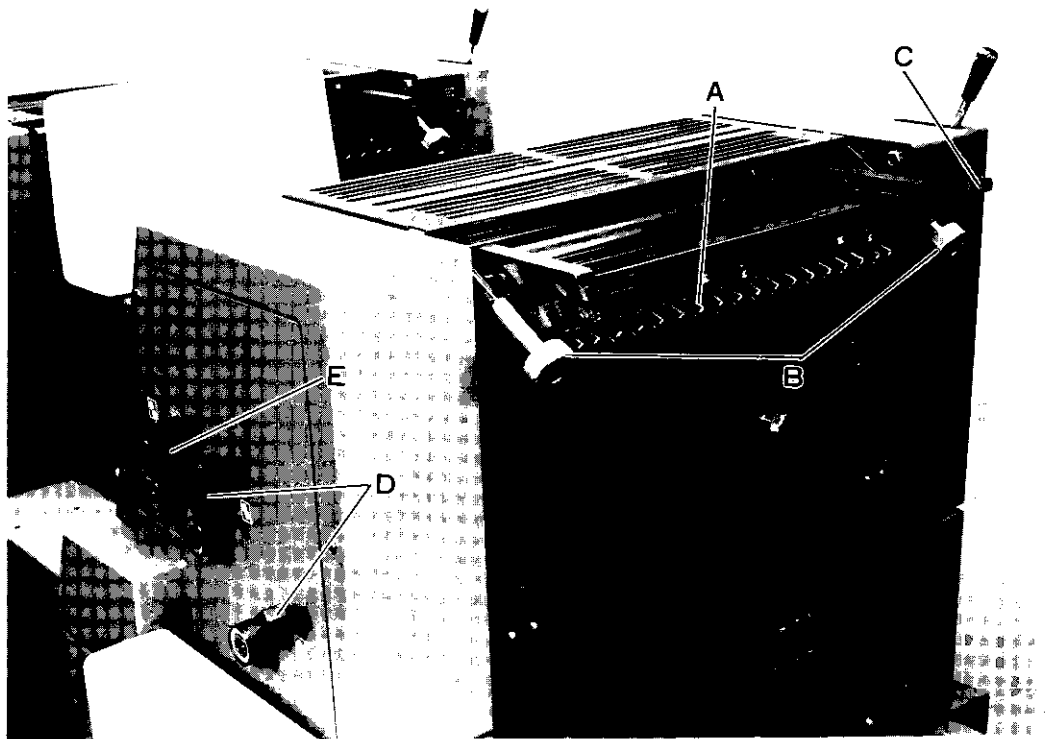

**A. Ink Volume Control Screw**

Turn these screws (1) to increase or decrease the clearance between the blade (2) and the fountain roller (3) to control the ink feed volume based on the printing image.

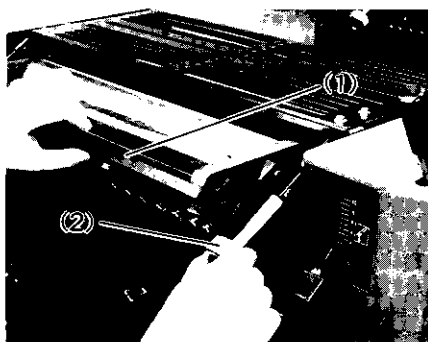

**B. Ink Fountain Fixing Knob**

This is used to fix the ink fountain (1).

(Reference) Setting the ink fountain

Push the fountain up and fix it using the 2 knobs (2).

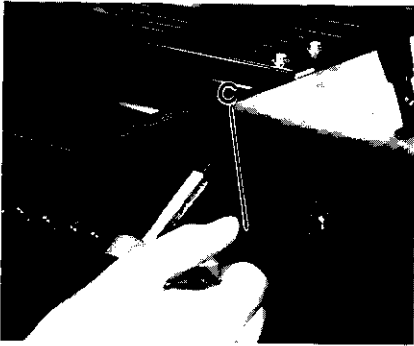

**C. Ink Feed Volume Control Lever**

This lever is used to control the total ink feed volume. The ink feed volume is indicated on the scale. Moving the lever toward a larger number increases the ink feed volume.

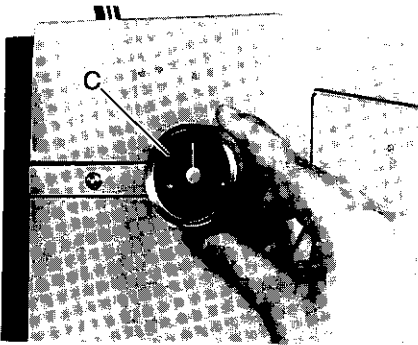



**C. Ink Feed Volume Control Dial**

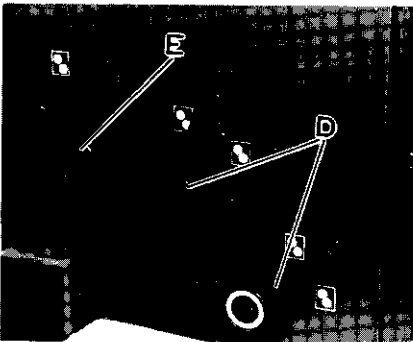

This dial is used to control the total ink feed volume steplessly. The ink feed volume is indicated on the scale. Turning the dial toward a larger number increases the ink feed volume.



**D. Ink Form Roller Release Lever**

-  Position . . . . The ink form roller is always separated (OFF) from the plate surface. Set the lever in this position when the machine will not be used for a long period.
-  Position . . . . The ON/OFF of the ink form roller is controlled by the operating lever. Set the lever at this position when printing.

**E. Water Form Roller Release Lever**

-  Position . . . . The water form roller is always separated (OFF) from the plate surface. Set the lever at this position when checking the ink form roller pressure or when doing waterless printing.
-  Position . . . . The ON/OFF of the ink form roller is controlled by the operating lever. Set the lever at this position when printing.



## 2-9 Delivery Section

### 1) Delivery Section 1

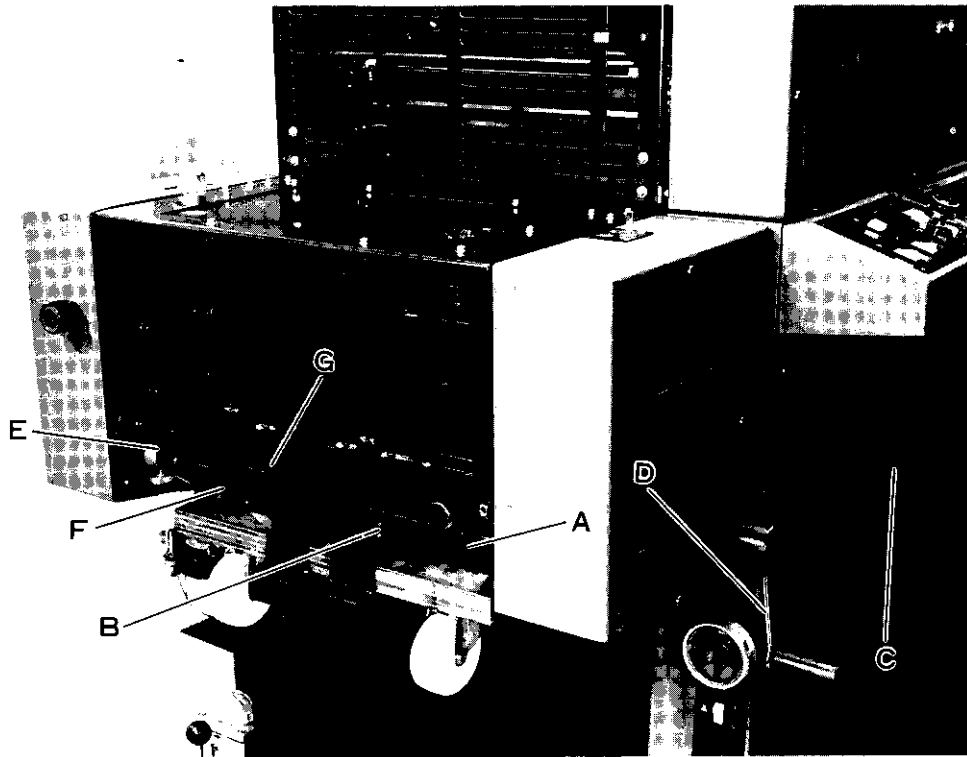

#### A. Delivery Jogger Side Guide

This guide jogs to even up the sides of the printed sheets delivered onto the delivery table dolly.

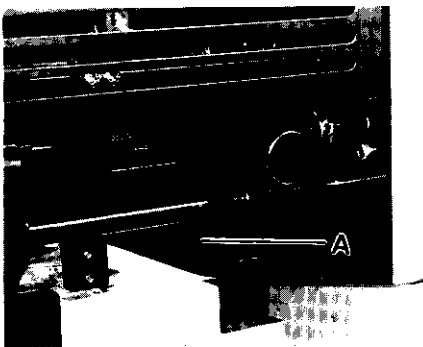

#### B. Paper Drop

This drops the printed sheet of paper on to the delivery pile after it is released by the delivery grippers. Adjust the paper drop position depending on the size of the paper being printed.



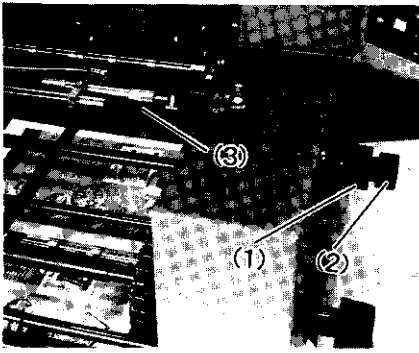

**C. Back Guide**

This guide jogs to even up the back and the front of the delivery pile. Loosen the fixing knob (1) and when turning the knob (2), the back guide (3) position can be adjusted.

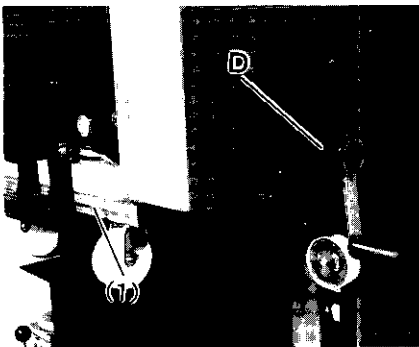

**D. Delivery Table Dolly Crank Handle**

This handle is used to manually raise or lower the delivery table dolly

(1).



Direction....The delivery table dolly is elevated.

Direction....The delivery table dolly is lowered

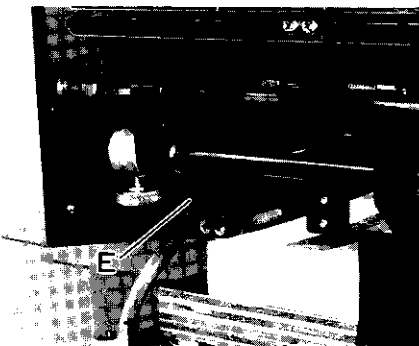

**E. Delivery Stationary Side Guide**

This is the fixed guide that is used to set the lateral position of the sheet delivered.

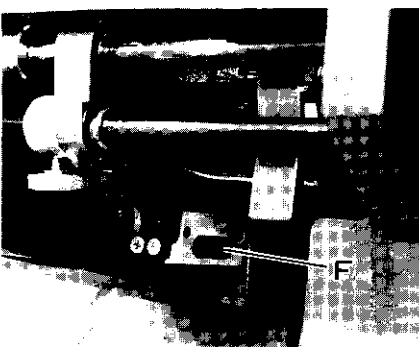

**F. Delivery Pile Lowering Sensor**

This sensor detects the height of the delivery pile and when the pile reaches the set height, the delivery table lowers automatically.



**G. Paper Pullout Device**

This device allows a printed sheet of paper to be removed to be checked. The paper receiving plate (1) receives the printed sheet momentarily before it is delivered onto the delivery table dolly, therefore it is easy to remove a printed sheet of paper.

2) Delivery Section **2**

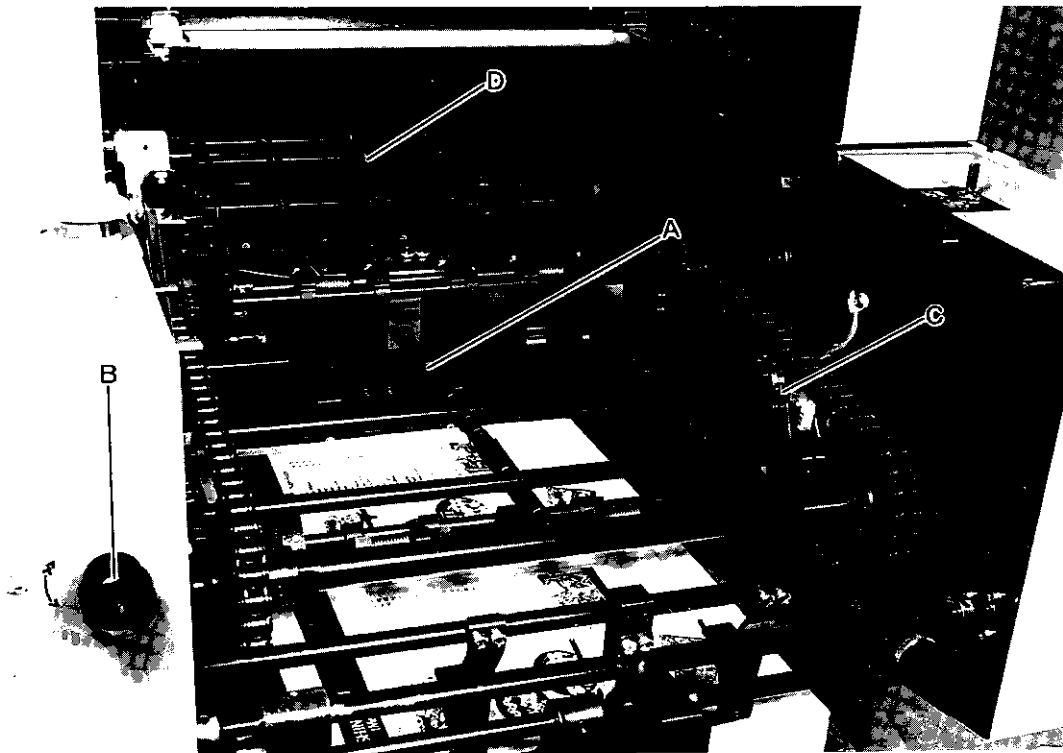

**A. Delivery Air Blower**

The force of the air drops the sheet of paper that is released by the delivery grippers on the pile. The delivery air blower can be opened or closed by turning the sleeve (1) depending on the size of the paper being printed.

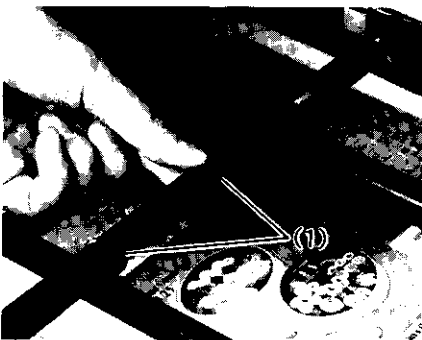

**B. Delivery Air Blower Control Knob**

Turn this knob to control the blower volume. When turning it in the clockwise direction the air blower volume will be increased.



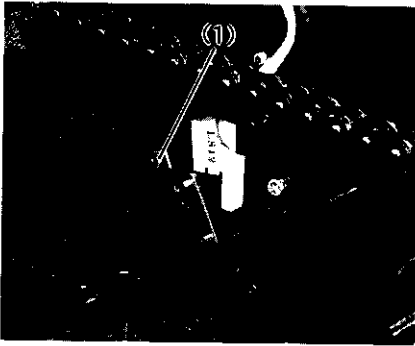

**C. Delivery Table Dolly Lower Limit Switch (1)**

When the delivery table dolly is fully lowered this switch will actuate and the suction feet vacuum will stop.

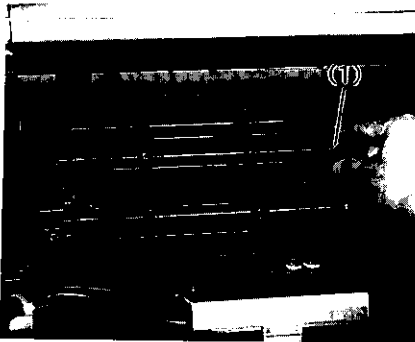

**D. Delivery Rotary Guide**

This is the guide that delivers the printed sheet of paper to the chain delivery gripper from the impression cylinder gripper. Set the rollers (1) so that they are not in the image area.

### 3) Spray Device

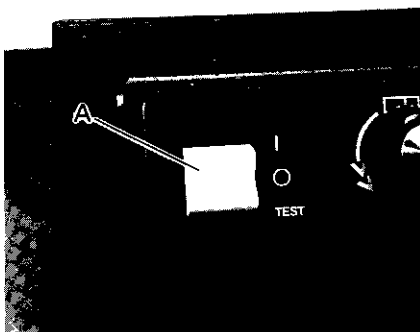
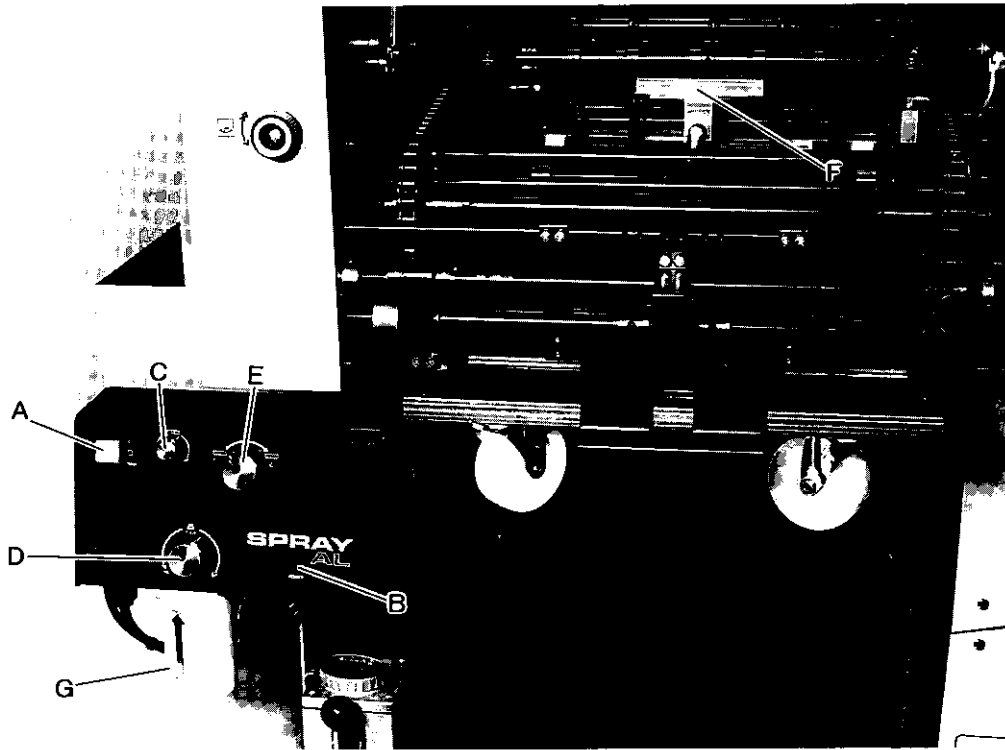

#### A. ON/OFF Switch

This is the spray powder device power switch.

- Position ... The device will operate and powder will be sprayed when paper passes under it.  
When using the device, generally keep this switch at this position.
- Position ... The device will not operate.
- Test Position ... The device will operate and spray the powder even when the paper does not pass.

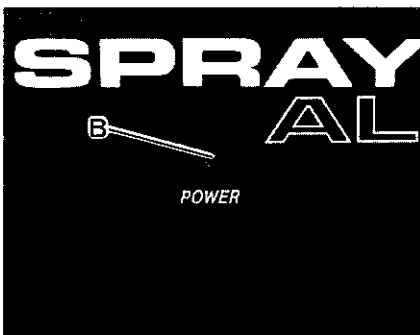

#### B. Power Lamp

This is the lamp that indicates the operation condition of the spray powder device.

- Flickering ... This indicates the spray powder device is ON.
- Lighting ..... This indicates the spray powder is being sprayed.

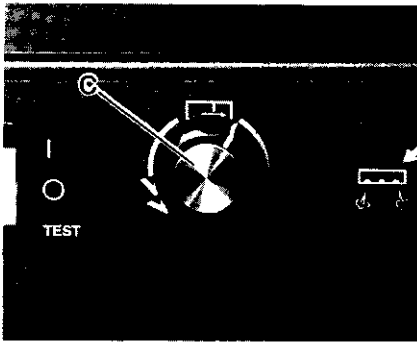

**C. Spray Time Adjustment Knob**

This is used to adjust the powder spraying time during one machine rotation.

When turning it in the counterclockwise direction, the spray time will be increased and the spray area will be wider. When adjusting the spray time, do it while checking the lamp (1) on the spray unit (F).

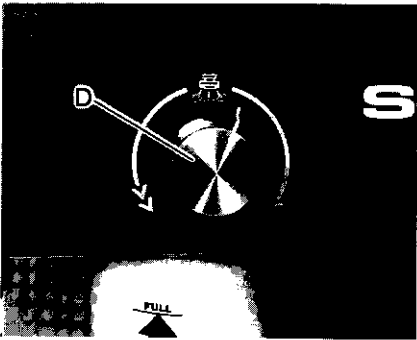

**D. Spray Volume Adjustment Knob**

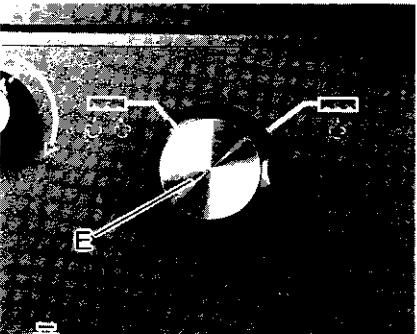

This is used to adjust the powder spraying volume.

When turning it in the counterclockwise direction, the spray volume will be increased. To prevent possible trouble, please adjust the spray volume to keep it at the minimum necessary.



**E. Spray Nozzle Selection Knob**

This is used to set the spray unit on either small size or A3 size depending on the paper size to be printed.

When the paper width is smaller than 220 mm, set it at the  position and when the paper width is larger than 220 mm, set it at the  position.

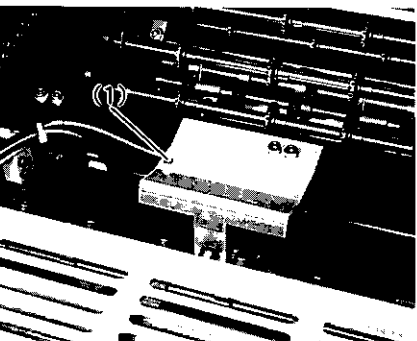

**F. Spray Unit**

This is the unit that sprays the powder on the printed sheet of paper.

The powder is sprayed while the lamp (1) is lighted. Set the machine rotation speed at 3,000 r.p.h. and adjust the spray time by using the spray time adjustment knob (C) so that the powder is sprayed only while the printed sheet of paper passes under the spray unit (or in the area you want).

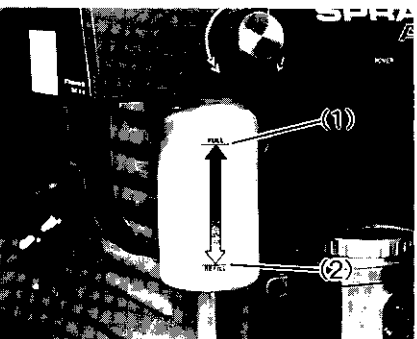

**G. Powder Bottle**

Put the spray powder in this bottle.

Do not fill the powder over the FULL line (1). Supply the powder before the powder level falls below the REFILL line (2).

## 2-10 Accessories

### 1) Centralized Oiling System, Ink Roller Cleanup Attachment, Electrostatic Eliminator

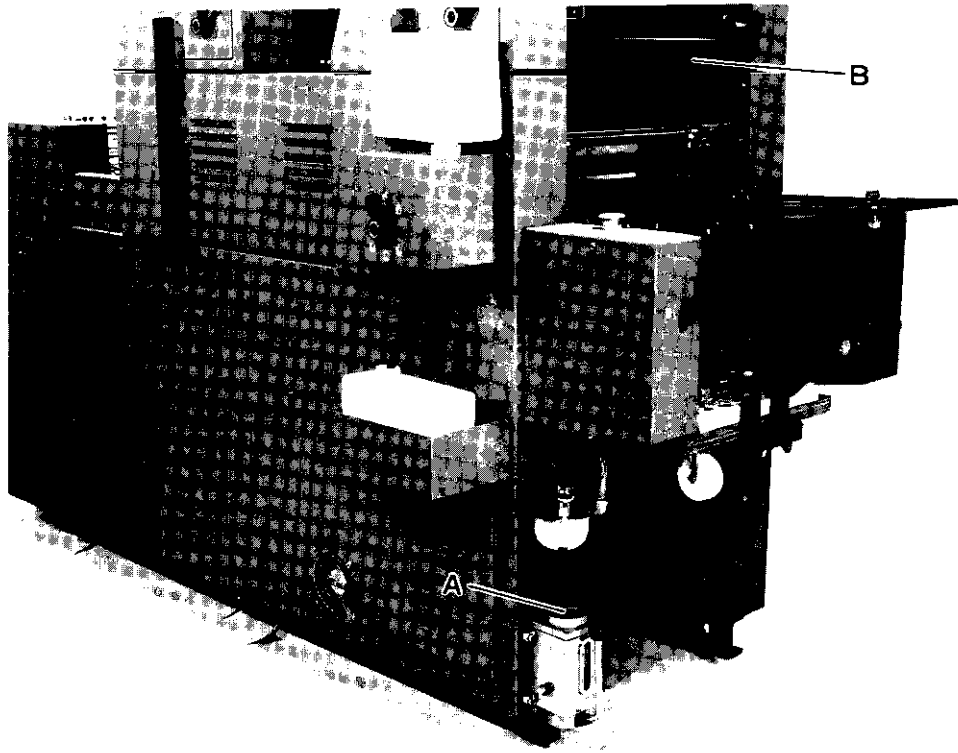

#### A. Centralized Oiling System

The centralized oiling system has been adopted therefore all of the important parts are lubricated by pulling a lever (1).

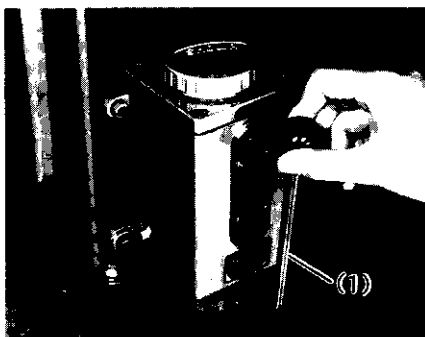
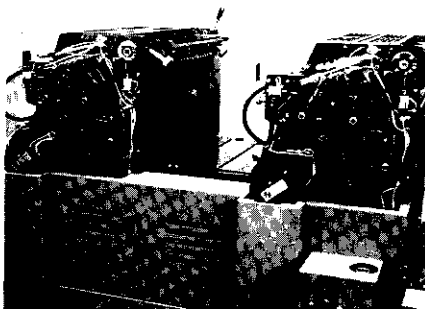

#### Centralized Oiling Pump Lever

Pull the lever (1) and release it after 2 to 3 seconds and the oil will be supplied. Pull the lever two to three times once or twice a day.

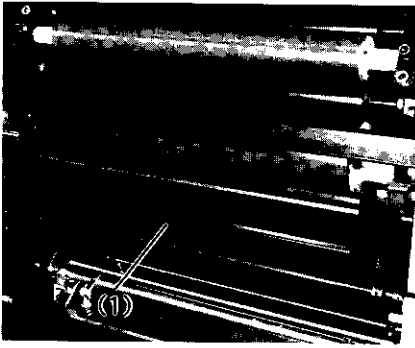

**B. Ink Cleanup Attachment Lever (4)**

The ink on the rollers is cleaned by using this ink roller cleanup attachment (1).

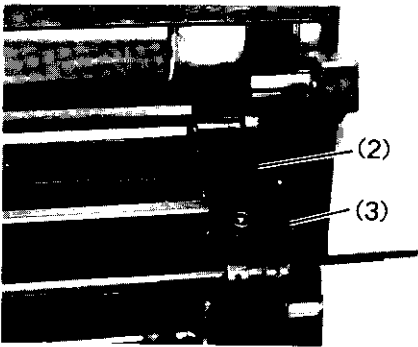

**(Reference) Mounting and Removing the Cleanup Attachment**

Pulling the pin (2) inside out on both the operation and the non operation, fit the pin into the pin hole on the bracket (3) to mount it. To remove it reverse the mounting procedure.

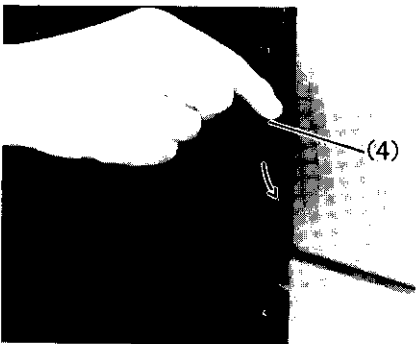

**Ink Roller Cleanup Attachment Lever (4)**

This is the lever used to operate the ink roller cleanup attachment. When pulling the lever down in the direction of the arrow the ink cleanup attachment comes in contact with the roller and the cleaning is done.

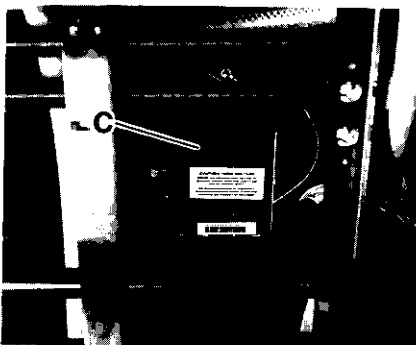

**C. Static Eliminator**

This is used to prevent poor paper feed and delivery caused by static eliminator that is generated on the paper during the printing.

The static eliminator will automatically go ON and OFF when the pump button (P. 15) is pushed ON or OFF.



Feeder Side

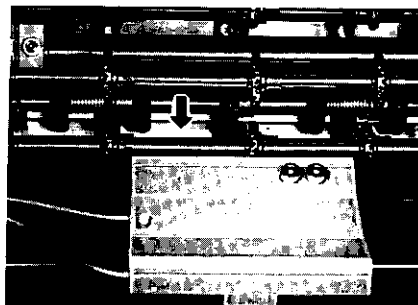

Delivery Side



## 2) Blanket Cleaning Device

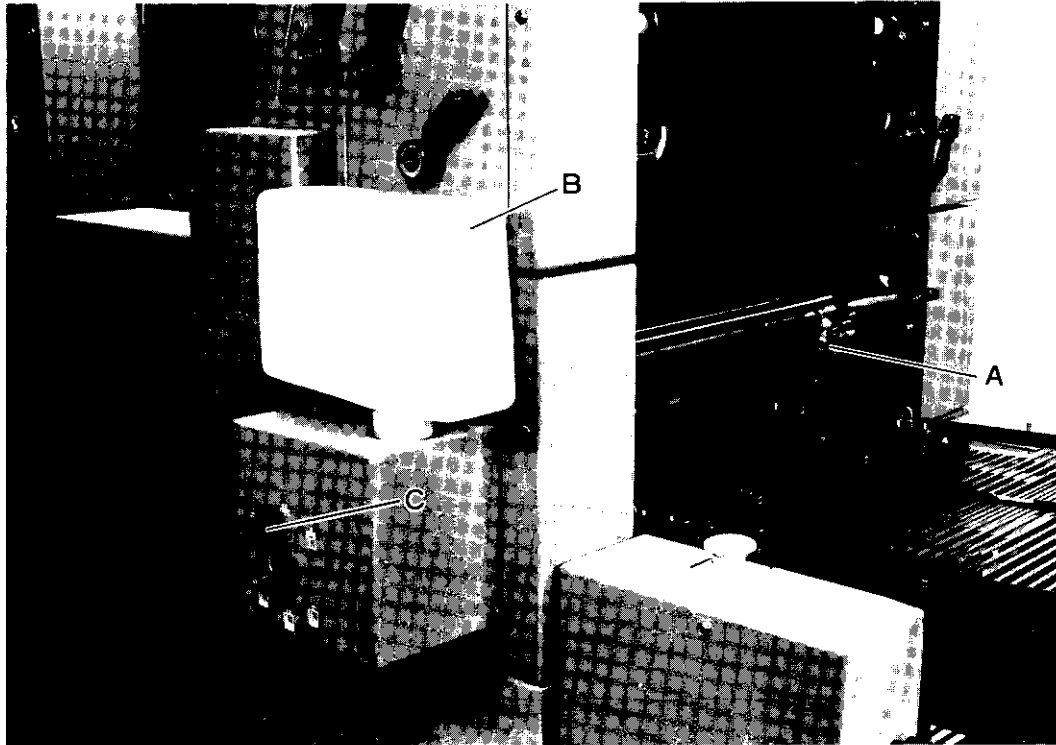

First unit

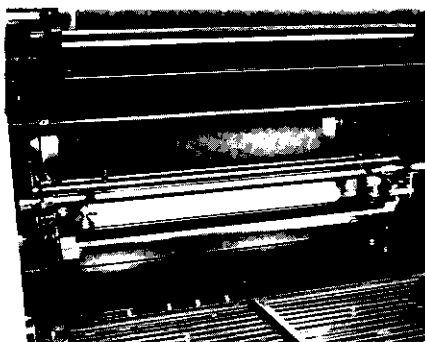

Second unit

### A. Blanket Cleaning Device

When pushing the blanket cleaning button (P. 15) the device will clean the blanket.

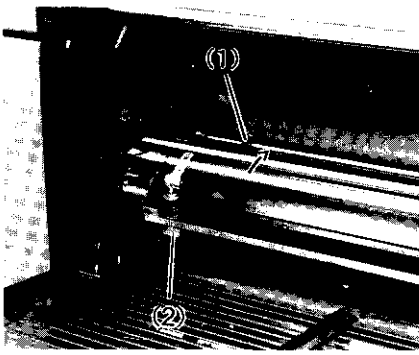

**The Roller Release Lever (1)**

When shifting the lever in the direction of the arrow mark, the cleaning roller and the squeeze roller will be released.

**The Sponge Roller Rotation Lever (2)**

When pushing the lever, the sponge roller will be rotated and the clean part of the sponge roller can be positioned to contact the cleaning roller.





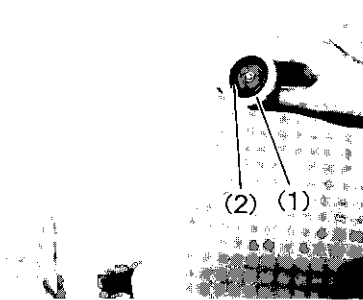

**B. Blanket Cleaning Solution Bottle**

This is the container that holds the blanket cleaning solution.

Note) On the inside of the bottle cap (1), there is a rubber packing (2). If the bottle is mounted without the packing, the blanket cleaning solution may leak out.



**C. Blanket Cleaning Solution ON/OFF Lever**

- 1  ..... The blanket cleaning solution is supplied to the first blanket cleaning device.
- 2  ..... The blanket cleaning solution is supplied to the second blanket cleaning device.
- 12  ..... The blanket cleaning solution is supplied to both the first and the second blanket cleaning device.
- 1  ..... The blanket cleaning solution is drained from the first blanket cleaning device.
- 2  ..... The blanket cleaning solution is drained from the second blanket cleaning device.
- 12  ..... The blanket cleaning solution is drained from both the first and the second blanket cleaning device.

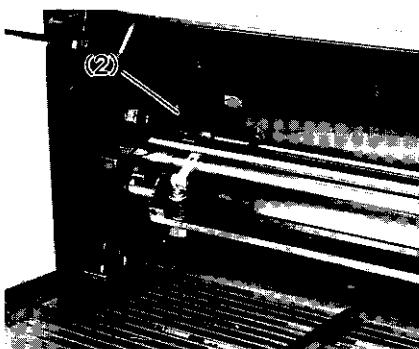
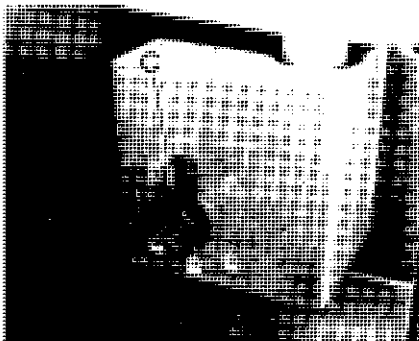

**(Reference) Mounting and Removing the Blanket Cleaning device**

1. To mount, fit the notch of the device on to the stud (1).
2. Pull the lock lever (2) toward the outside and then toward you (Operation Side, Non Operation Side).

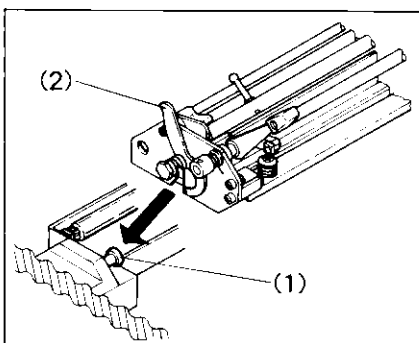

To remove the device push the lock lever(2) toward the cylinders.



# Ryobi 3302M

---

---

## Machine Operation Edition

This edition is composed of five chapters.

Chapter 1, 2 and 3 explain the basic printing procedures and points.

Chapter 4 explains the care after printing, regular inspection and maintenance items that are very important for the machine.

Chapter 5 explains the countermeasures to follow when troubles occur during the printing.

---

---



### Machine Operation Edition

Chapter 1  
Printing  
Preparation

Chapter 2  
Printing

Chapter 3  
Printing Practice

Chapter 4  
Maintenance and  
Inspection

Chapter 5  
Troubles and  
Countermeasures



## 1-1 Plate Marking and Setting the Water Section

### A. Plate Making

If the image position is incorrect, more time will be required for the vertical and the diagonal image adjustment before printing. Use the pre-register system to always keep the image at the same position, and to reproduce the image accurately.

- Register punch RP22 ..... (1)
- Register marking sheet ..... (2)
- Pre-register system positioning bar ..... (3)
- Pre-register system positioning pins ..... (4)

#### [Plate Making Using the Punch System]

1) Set the plate on the register punch RP22 and punch the holes.

2) Mount the plate (2) and the pre-register sheet (3) on the positioning bar (1). Next using the pre-register sheet (3) mark the reference lines and the center register marks on the plate (2).

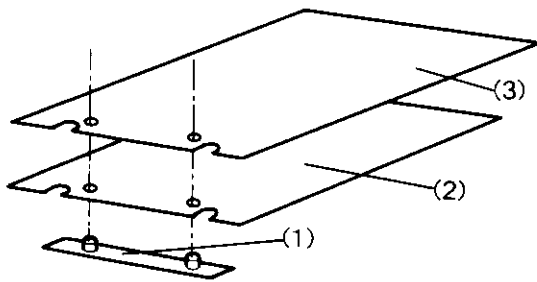

3) Mount the positioning pins (1) on vacuum printing frame and fit the punched plate and the punched film on the positioning pins and expose them.

(Reference)

If there are no punch holes in the film, align the center register marks marked on the plate and the center register marks marked on the film.

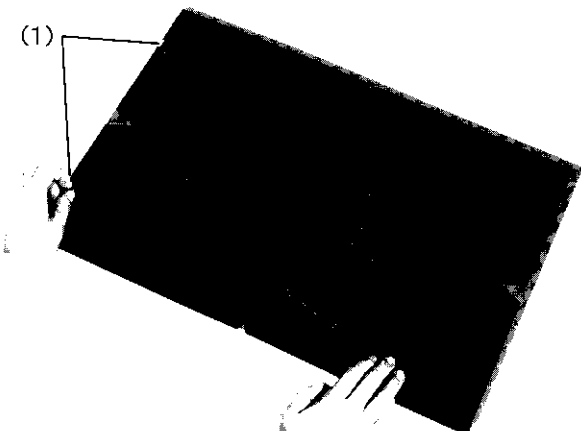
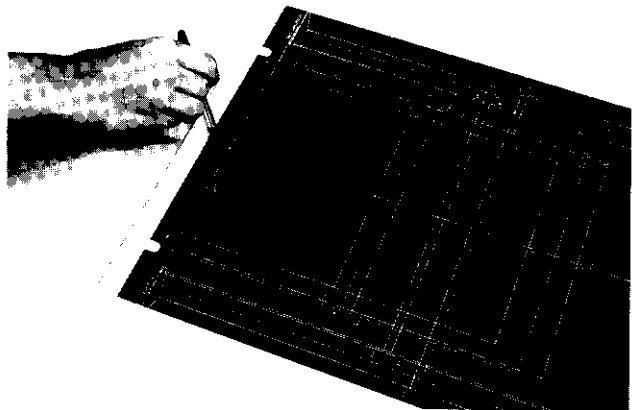
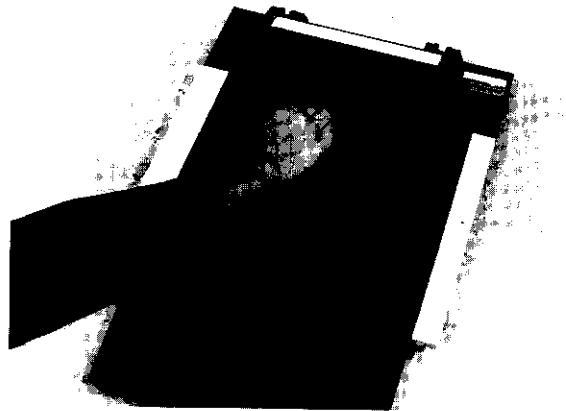
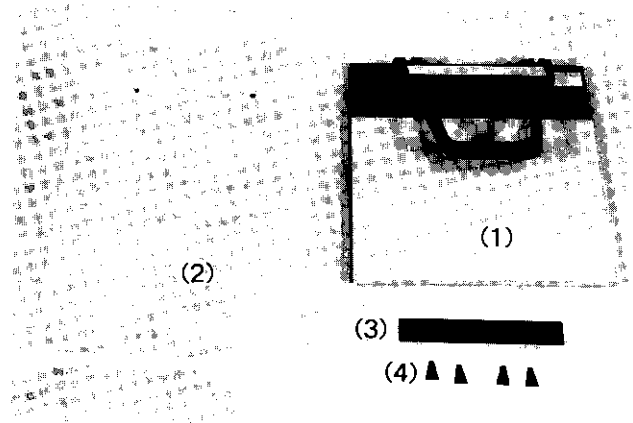
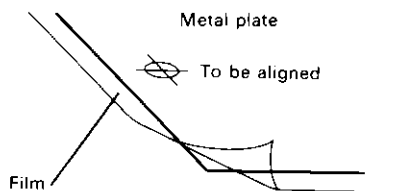

### B. Plate Inspection

Before mounting the plate on the cylinder, check the plate.

- 1) Wipe off any foreign particles on the back side of the plate.
- 2) Check that there is no damage to the plate surface or missing characters and that there are no stains on the image.

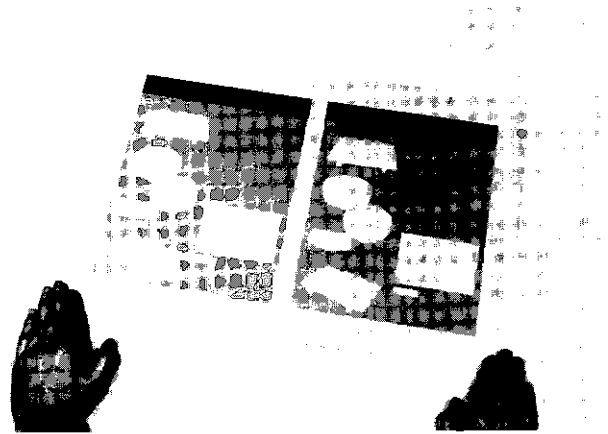

### C. Plate Pressure Adjustment

- 1) Measure the plate thickness.

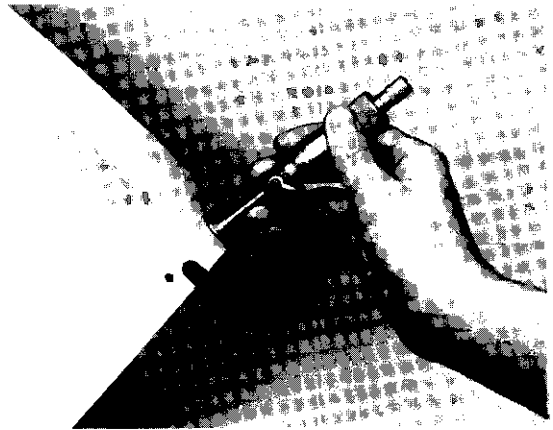

- 2) Set the plate pressure dial to match the plate thickness.



### D. Mounting the Water Roller

- 1) Mount the water form roller (1).

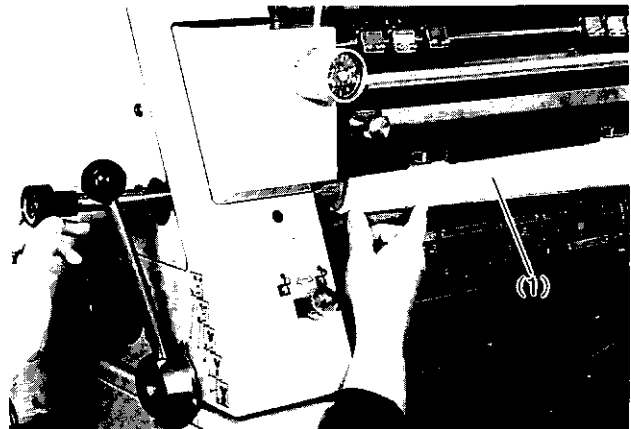

(Reference)

With setting the water form roller release lever (2) at the  position, the water form roller can be mounted easily.

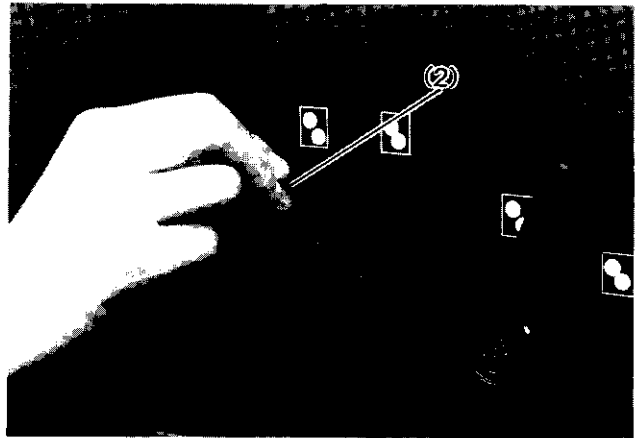

2) Mount the water ductor roller.



### E. Mounting the Plate

1) Release the emergency stop button (1) (On both the first unit and the second unit) and push the forward inching button (2). The plate cylinder will rotate at low speed and stops automatically when the clamp is positioned where it is easy to mount the plate.

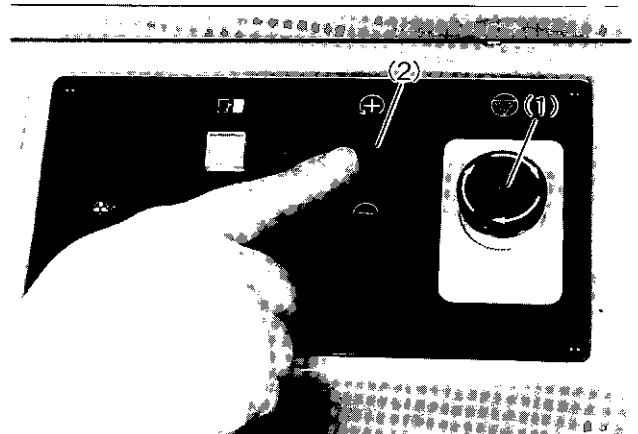

2) Turn the bolt (1) and set the clamp (2) at the center of the cylinder. (Align the centering line of the clamp (2) with the centering line of the cylinder (3).)

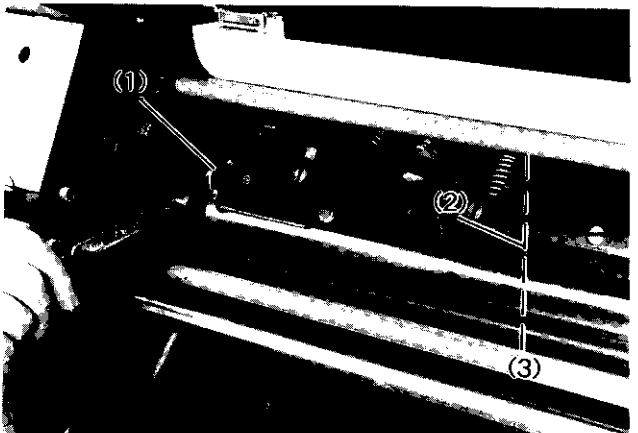



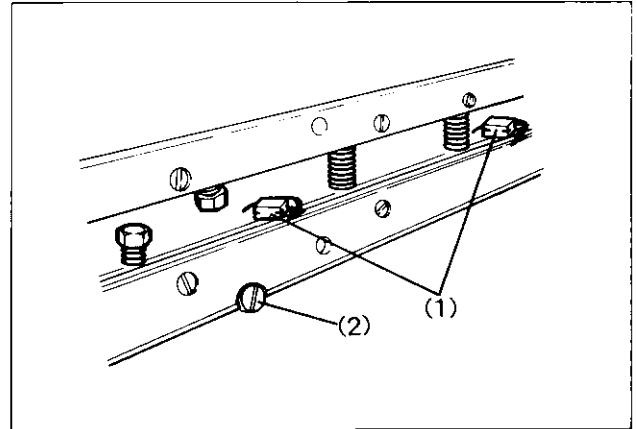

- 3) Mount the plate in the clamp and turn the operation side and the non-operation side clamp bolts (1) alternately a little at a time until the red mark is visible to fix the leading edge of the plate.

Note) The leading edge of the plate has to be positioned on the positioning pins (2) exactly and then fix it.

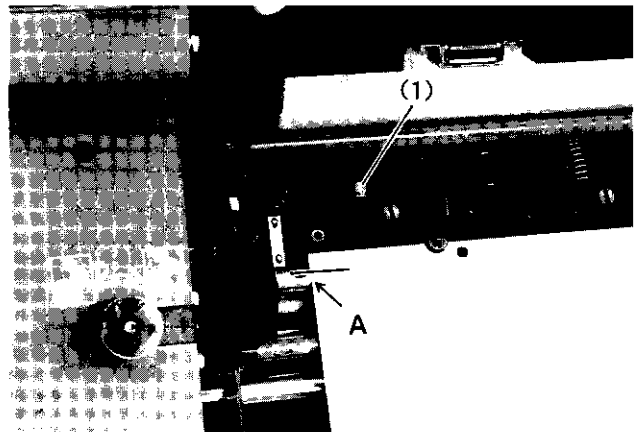

- 4) Turn the adjustment bolt (1) at the leading edge to align the line A (the reference line on the cylinder and the reference line on the plate).





- 5) Shift the operating lever to the  position so that the water form roller is in contact with the plate and push the forward inching button  to mount the plate on the plate cylinder.

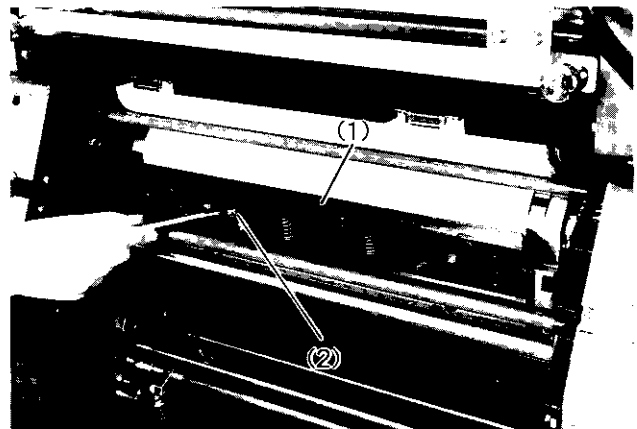

- 6) Mount the leading edge of the plate in the clamp (1) and turn the clamp bolt (2) so that the red mark is visible, to fix the tail edge of the plate.

Note) When turning the clamp bolts (2), turn the operation side and the non operation side. Alternately a little at a time.



- 7) Return the operating lever to the  position and turn the quick tensioning bolt (1) fully in the direction of the arrow.

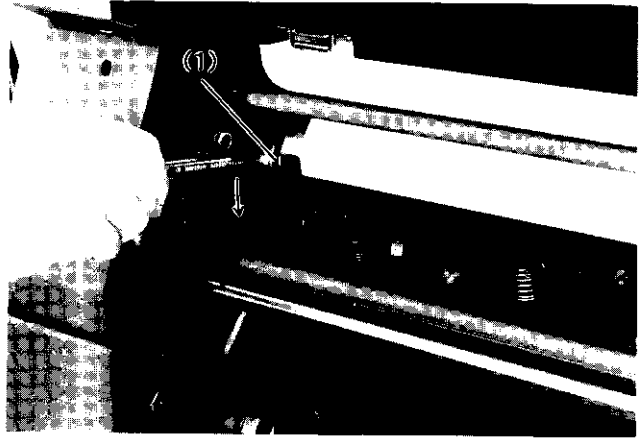

- 8) Turn the bolts (1) to tension the plate.

(Caution)

To assure the safety, after mounting the plate, be sure to mount the plate cylinder gap safety cover.

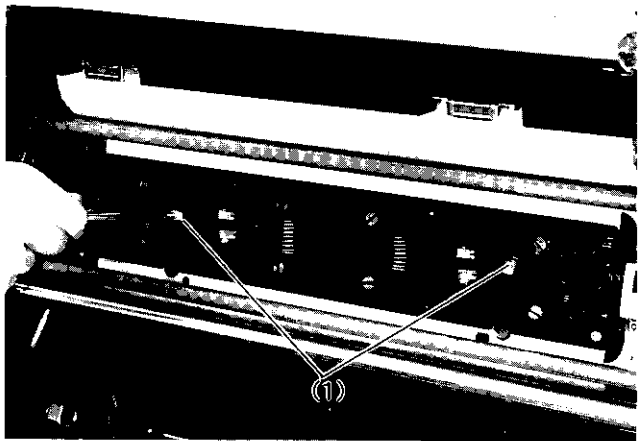

#### F. Setting the Water Section

- 1) Put the dampening solution into the bottle (1) and add etching solution and gum solution depending on the type of the plate being used.

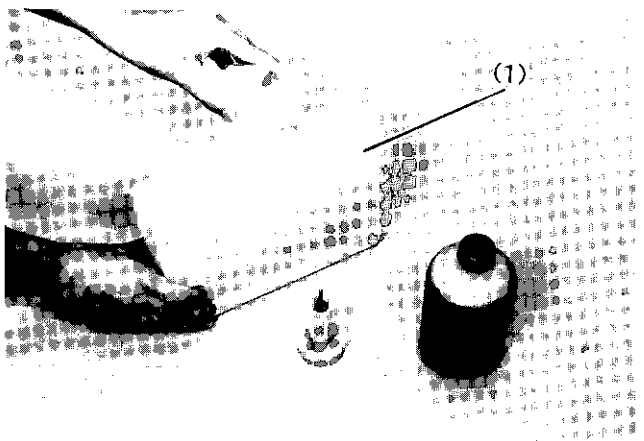

- 2) Mount the water bottle in the bottle bracket (1).



- 3) Turn the water fountain roller using the lever(1) and check that the dampening solution is fed to the water form roller evenly.

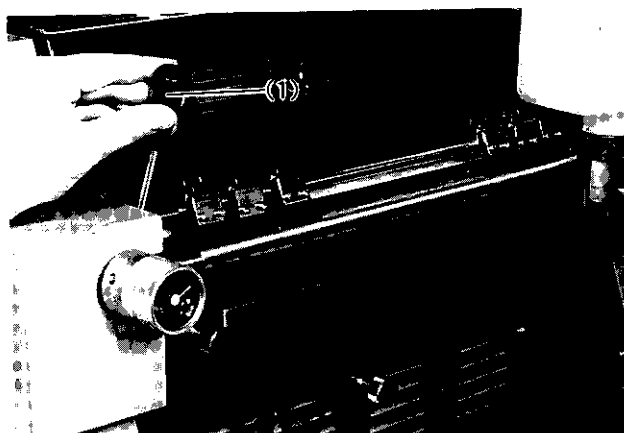

Note) If there are any stains or oil on the water fountain roller and the water oscillating roller, the balance between the dampening solution and the ink will not be balanced during the printing and stains will appear easily on the printed material therefore if any stains or oil appear please clean the rollers well.

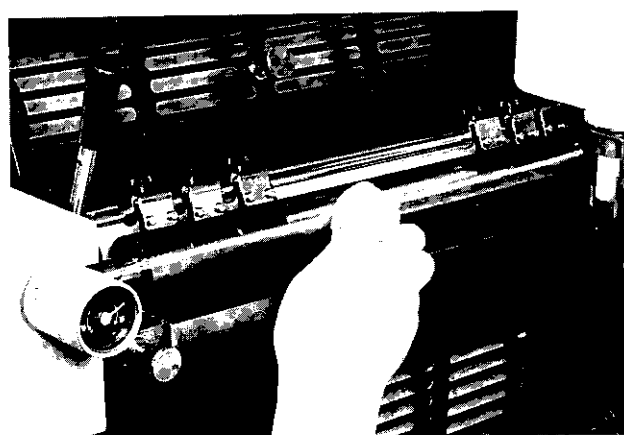

## 1-2 Setting the Paper Feed Section

### A. Paper Pile

- 1) Put the paper pile board (2) on the paper pile board supports (1).

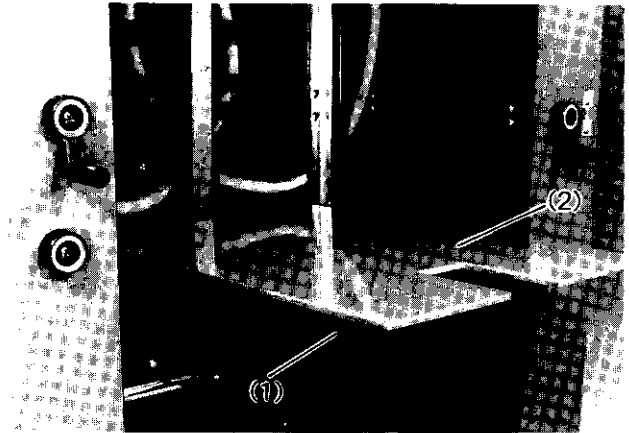

#### (Reference)

There are four different size paper pile boards included with the machine. Use the board that corresponds to the sheet of paper shown in the illustration on the right.

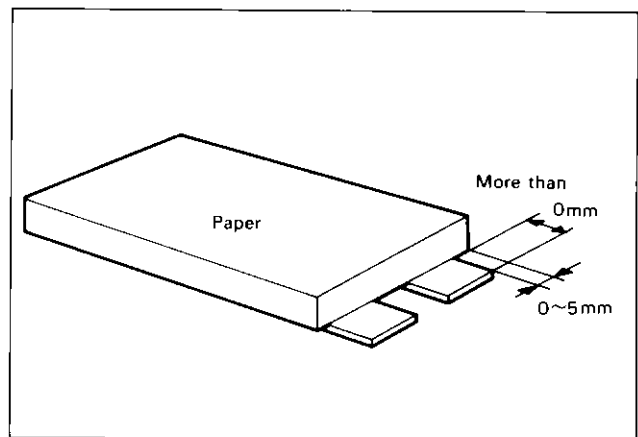

A multi-size paper pile board that can hold paper from 170 × 210 mm to 340 × 450 mm in size is available.

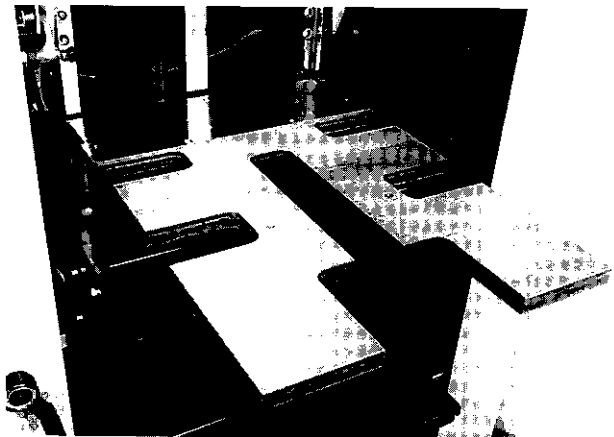

- 2) Set the vertical guides (1) on both edges of the paper and then pile the paper.

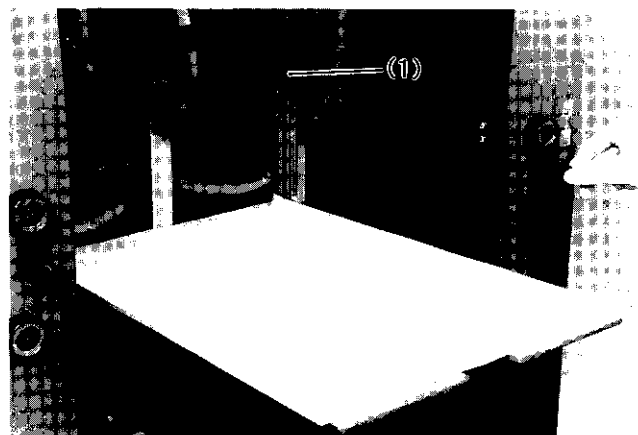

Position the vertical guide (1) using the scale stay (2).

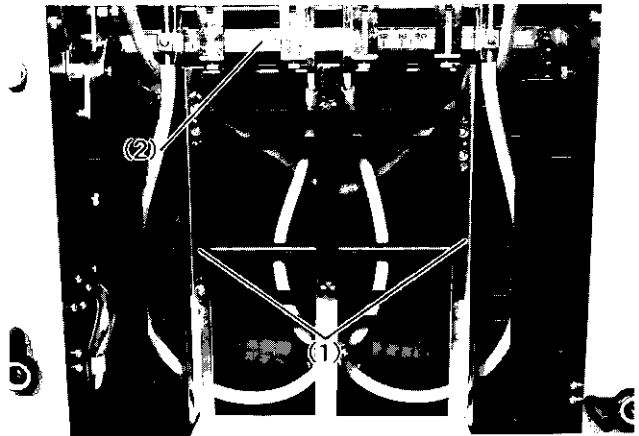

### B. Setting the Sheet Separator

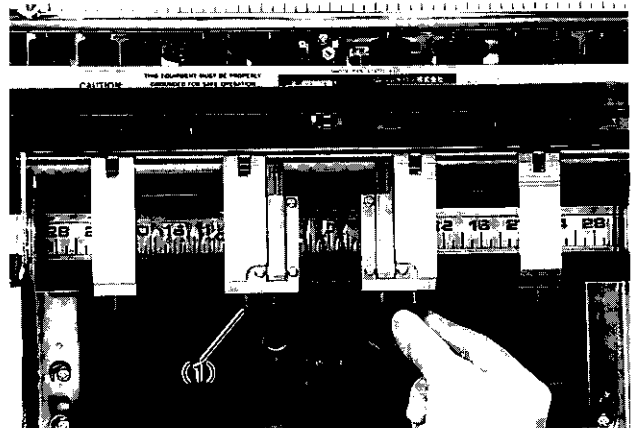

When loosening the screw (1), the sheet separator can be moved.



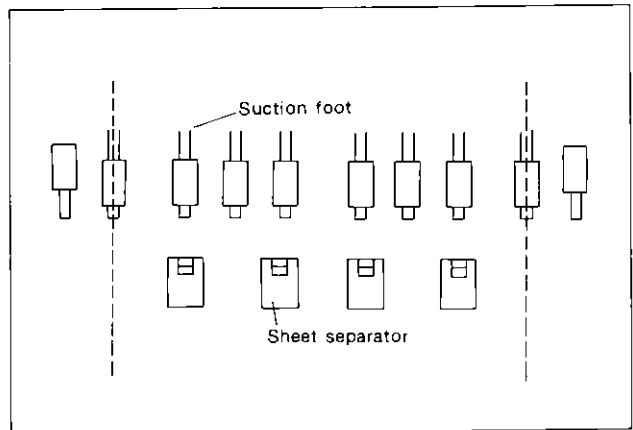

Note) Please try to use four sheet separators at all times. The sheet separators should be located a little inward from the suction feet on both sides.

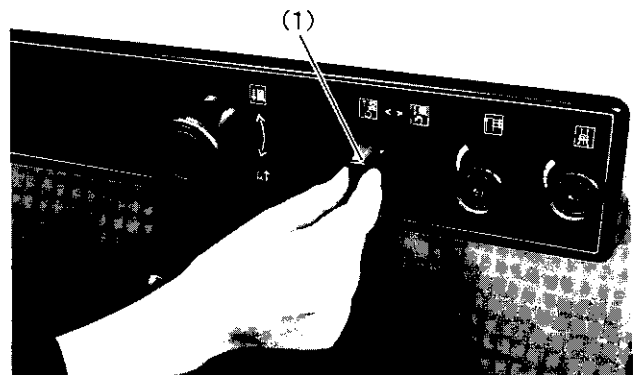

### C. Paper Height Adjustment

1) Push the drive button  to start the machine and then set the release lever (1) to the  position. The paper feed table is raised automatically.



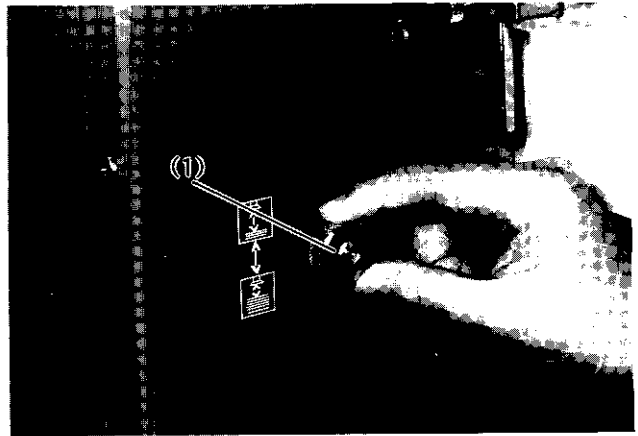

2) Determine the paper height by turning the height control knob (1). First turn the height control knob (1) from 3 to 4 complete turns in the  direction. After the paper feed table stops its automatic elevation, gradually turn the knob in the  direction to determine the height of the paper pile.

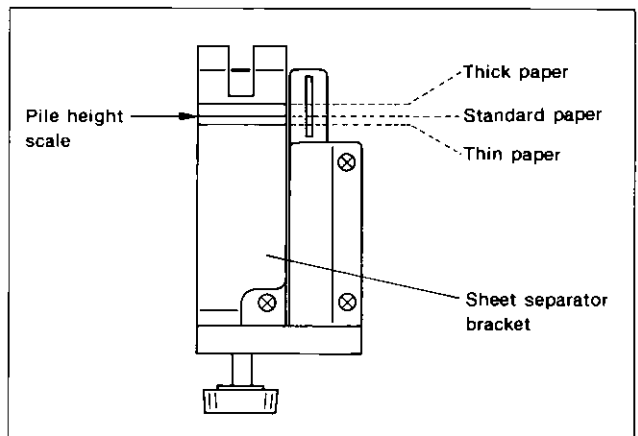

The height of the paper pile should be adjusted based on the thickness of the paper as shown in the illustration.



Note) If the height of the paper pile is too high, lower the paper feed table and adjust it again. To lower the paper feed table set the release lever (1) to the  position and turn the crank handle (2) in the  direction.

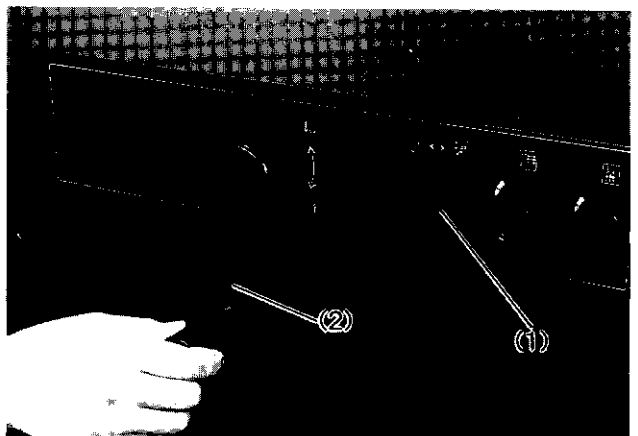

#### D. Setting the Paper Feed Side Guides

Set the micro side guide (1) so that it is in contact with the side of the paper pile and set the side guide (2) so that its plate spring is bent about 2 to 3mm. Set the back guide (3) so that the plate spring is lightly in contact with the back of the pile. At the same time set the back guide (3) so that it is located in the notched section of the paper pile board. These guides can be moved by loosening the screws (4).

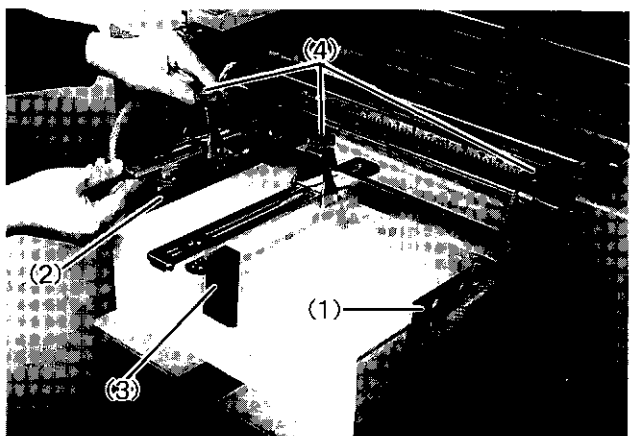

### E. Setting the Suction Feet

Stop the vacuum to the suction feet that are only partially on or completely off the paper.

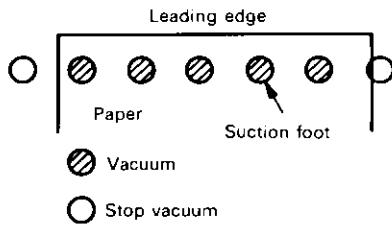

When printing on thick paper, use the rubber suckers on every suction foot.

Note) When the rubber sucker wears out, the suction foot vacuum force will decrease causing paper feed problems. If this occurs replace the rubber sucker with a new one.

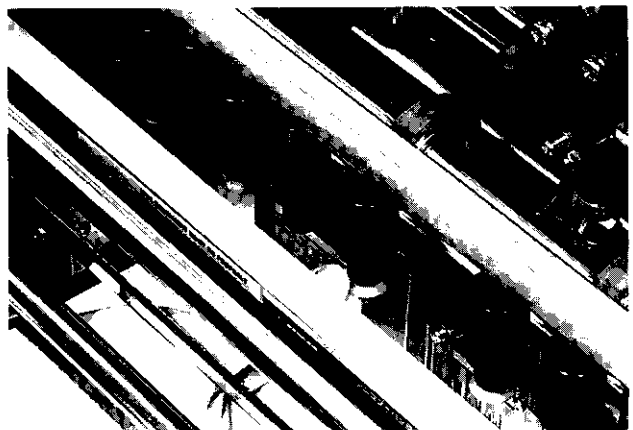
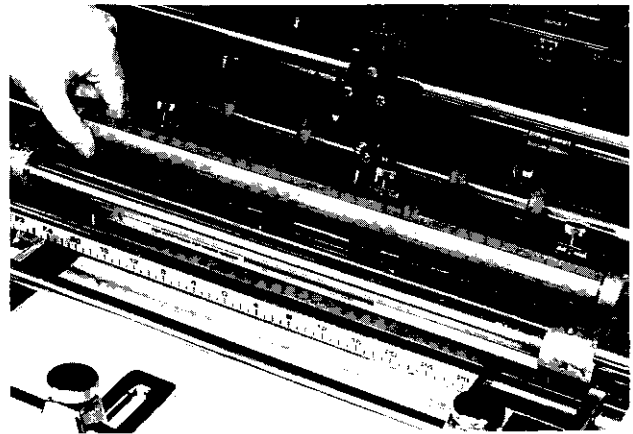
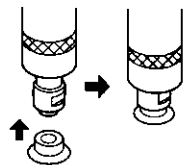

### F. Control the Vacuum and the Blower Volume

1) First control the vacuum volume. When printing on paper with a thickness of over 0.1 mm, set the vacuum control knob (1) to the maximum (fully turned clockwise) position. For paper with a thickness less than 0.1 mm, turn the knob 1/2 to 1 turn back from the maximum position.

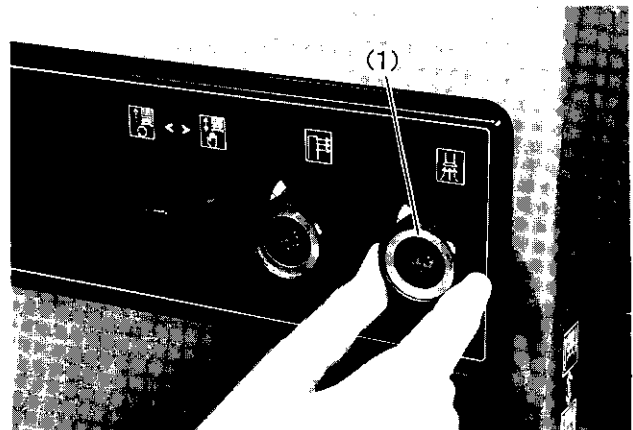

2) Control the blower volume of the center blower and the side blower. Turn the blower control knob (1) in the clockwise direction until the paper comes lightly in contact with the sheet separators.

Note) If the blower volume is too strong the paper may float over the sheet separators causing poor feed trouble. Therefore please be careful when doing this adjustment.

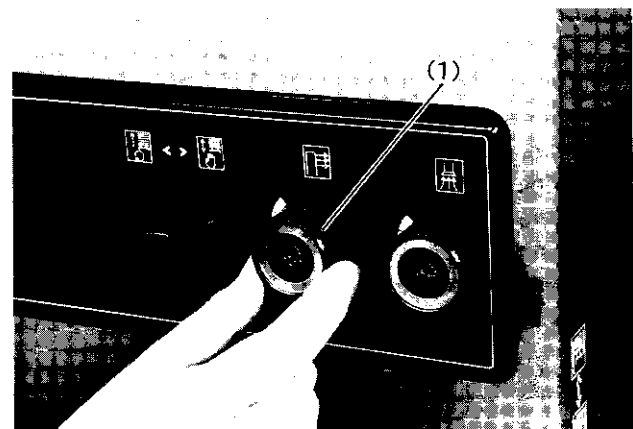

After determining the paper position, loosen the screw (1) and adjust the height of the side blowers so that the top 5 to 6 sheets of paper are separated.

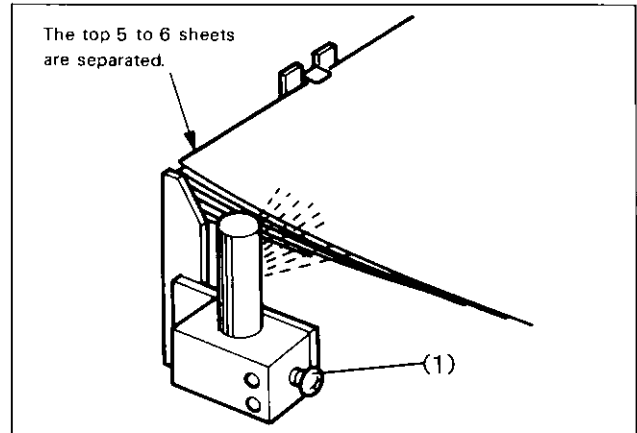
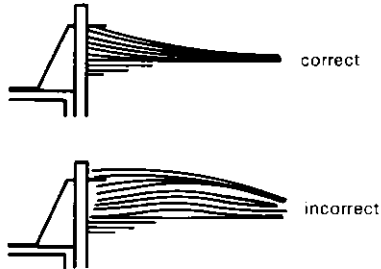

(Reference)

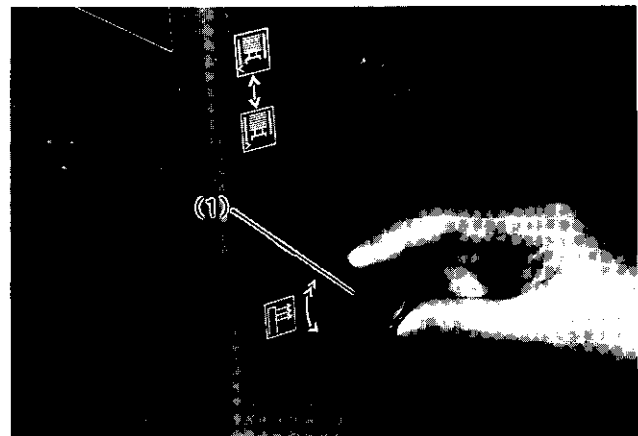

When printing with coated paper, if the paper separation is poor adjust the auxiliary side blower to completely separate the sheets of paper. When turning the adjustment knob(1) in the clockwise direction, the blower volume is increased.

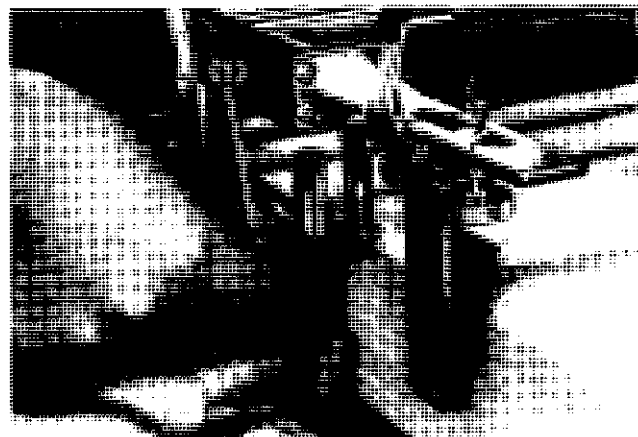
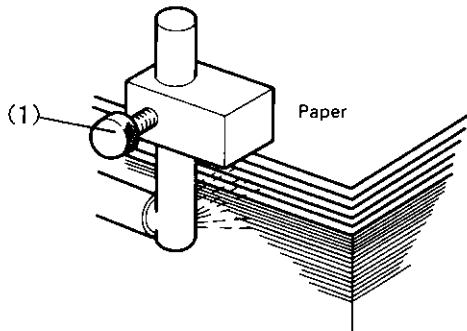

Adjust the blower volume and the height of the blower nozzle so it separates the top 15 to 20 sheets of paper. Loosen the screw (1) to adjust the height of the nozzle.)



**G. Setting the Double Sheet Detector**

- 1) Push the crawl speed button  and the drive button  to operate the machine on crawl speed.

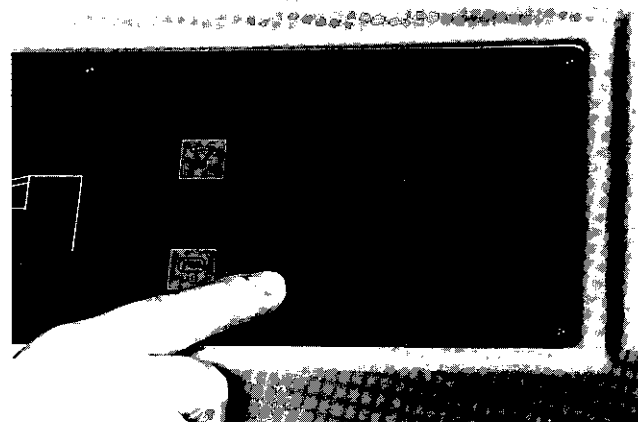



- 2) Make a strip of paper from a sheet of paper to be used for printing and fold it in half as shown in the illustration and insert it between the detector roller (1) on the double sheet detector and the feed roller (2).

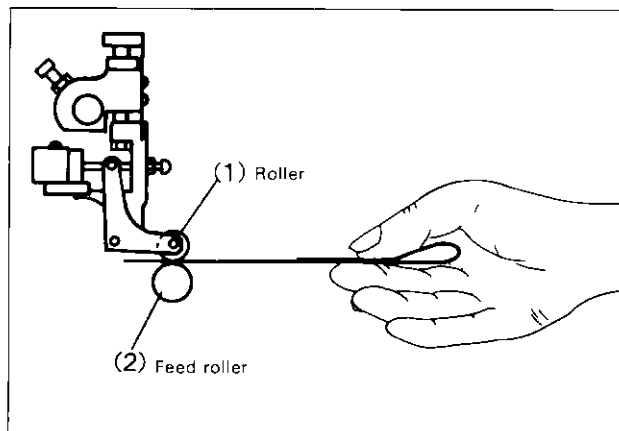

- 3) Turn the adjustment knob (2) to adjust the double sheet detector so that the shutter (1) actuates when a doubled sheet of paper is fed but does not open the shutter (1) when only one sheet of paper is fed. When turning the adjustment knob (2) in the direction of the arrow, the clearance between the detector roller and the feed roller will be reduced.

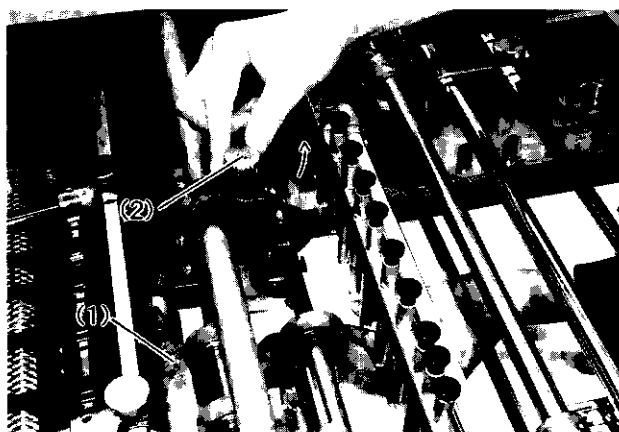

#### H. Setting the Pullout Roller

- 1) The pullout roller is set as shown in the photo except when feeding minimum size paper. (For setting postcard size paper, see P. 84.)  
Note) Set the pullout roller so it does not contact the suction foot.

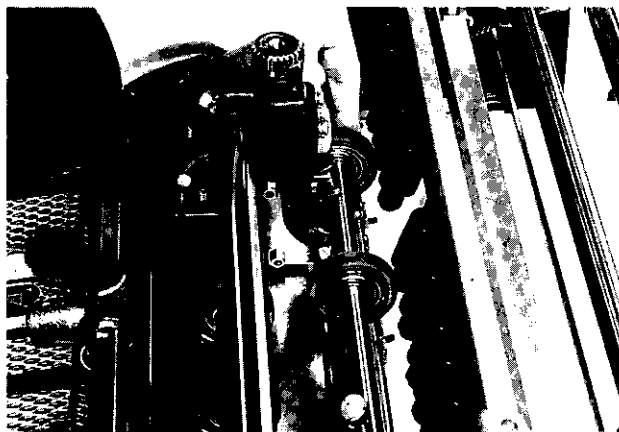

- 2) Adjust the pressure of the pullout roller. Run the machine and when pressing on the pullout roller (1) with your finger lightly, adjust the pressure so that the roller stops. (Adjust the pressure so it is the same on both the operation and the non operation sides.) When turning the adjustment knob (2) in the counterclockwise direction, the pressure is increased. Then start the paper feed and do the micro adjustment of the pressure so that the paper is not skewed on the feeder board.

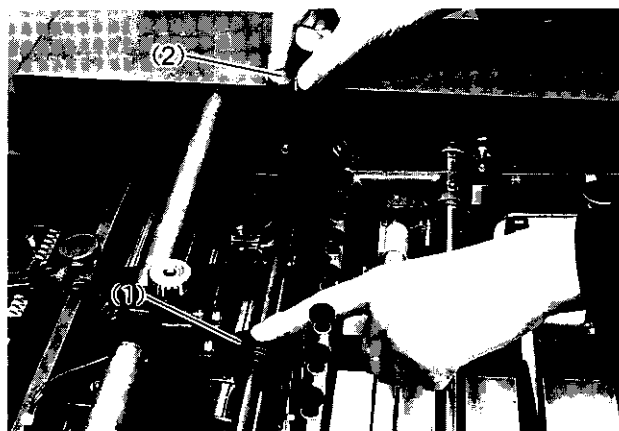

### I. Setting the Guide Roller

Normally set 4 guide rollers at the position where they do not contact the retainers. (P. 68)

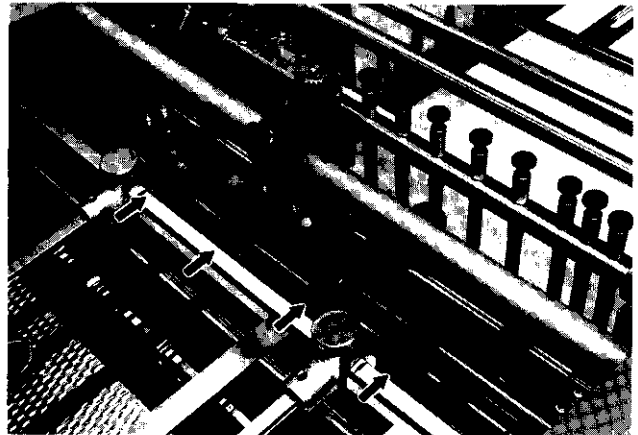

(Reference)

When the double sheet detector actuates, the double sheet should drop onto the paper tray. But if the double sheet has a large curl, sometimes it will not drop onto the paper tray. If this happens, set the guide roller (1) on the part of the sheet that is curled.

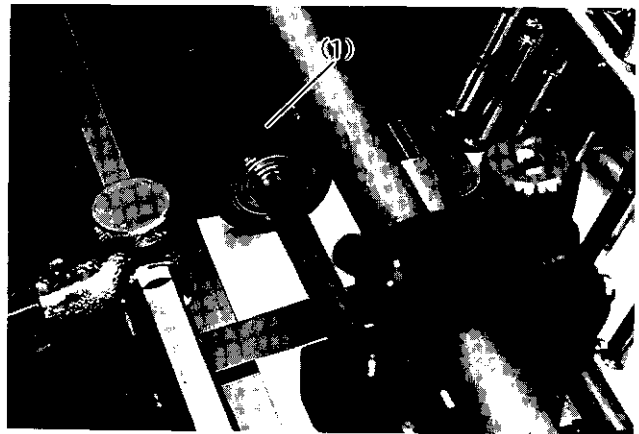
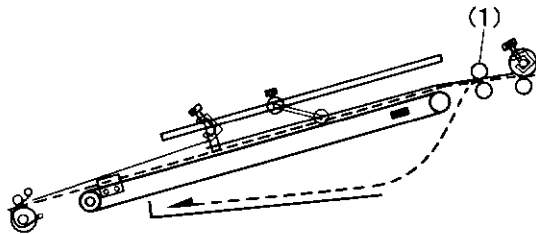



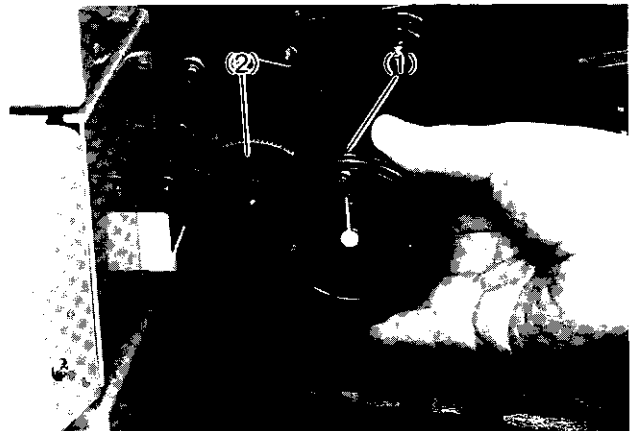

### 1-3 Setting the Feed Board

#### A. Setting the Push Side Lay

- 1) Set the indicator on the push side lay adjustment dial (1) in the center (2 on the scale).  
Set the flat spring micro adjustment knob (2) in the middle of the total moving volume.



- 2) Push the crawl speed button , the drive button , and the pump button . Shift the feed lever to the  position and feed one sheet of paper.

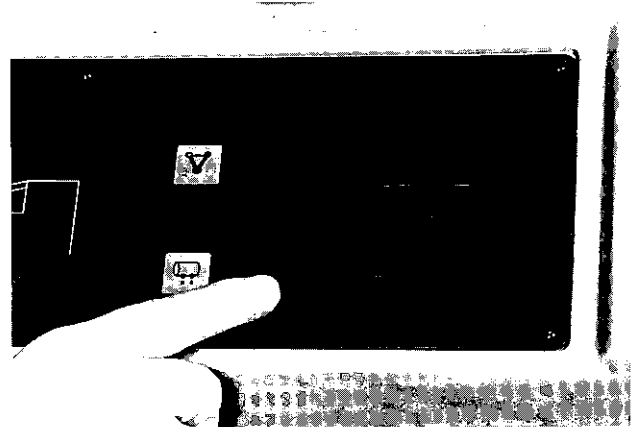

- 3) Stop the machine at the point where the paper reaches the paper stop finger.

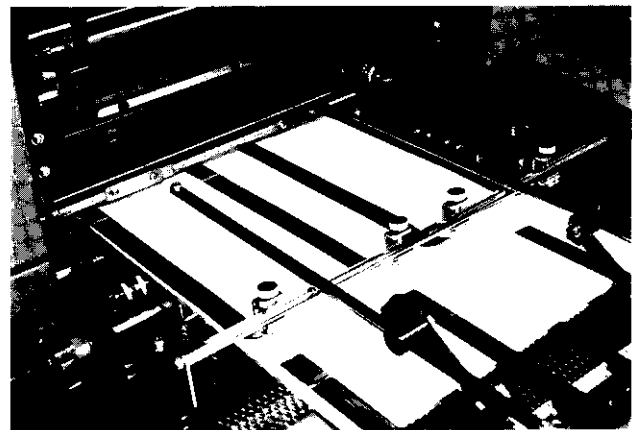
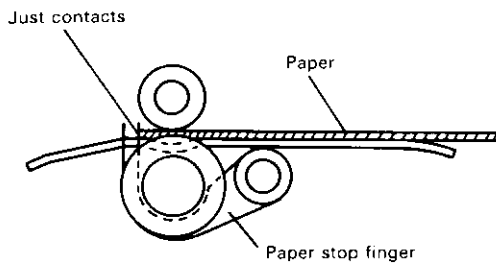

- 4) Loosen the fixing screw (2) of the flat spring (1) and position the flat spring so it is about 1 mm from the side edge of the sheet of paper and fix it.

(Reference)

On the flat spring plate (3), there is a scale with 1 mm interval markings. Use this to set the standard position of the spring.

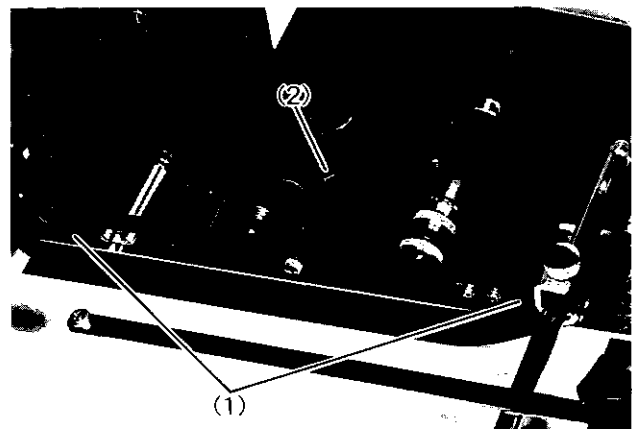
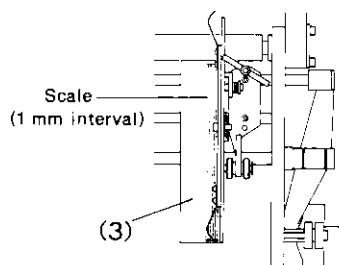

- 5) Push the forward inching button  and stop the jogger guide (1) at its fully in position.  
If the jogger guide (1) does not contact the sheet of paper, loosen the lock nut (2) and adjust by turning the screw (3) so it contacts the sheet of paper and is parallel to the sheet of paper.

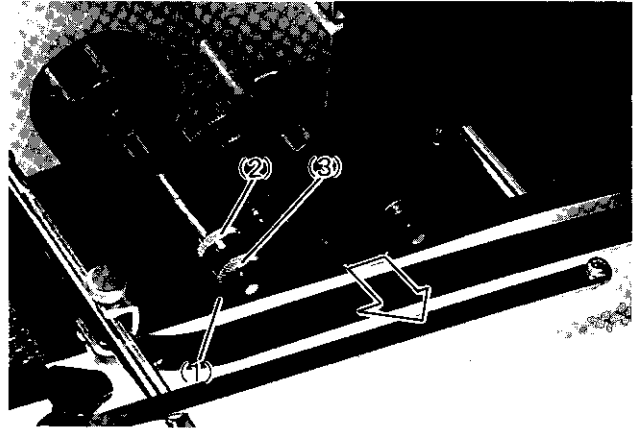

- 6) Loosen the screw (1) and adjust the jogger guide (3) position so the flat spring (2) is bent about 1 mm. Do the micro adjustment of the flat spring bending volume by using the micro adjustment knob (4).

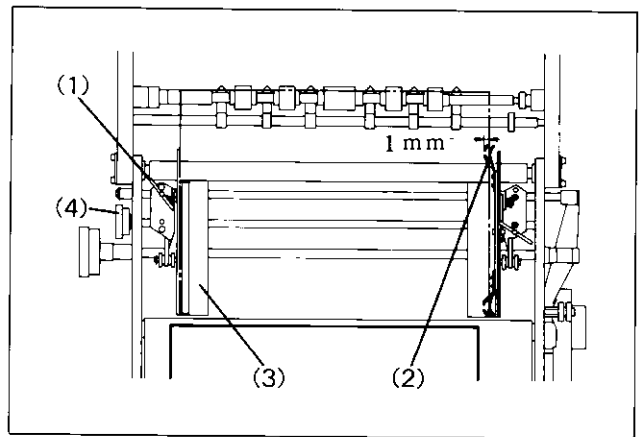

#### (Reference)

**Switch over the jogger guide from the operation side to the non operation side.**

#### [Switching over procedures]

- 1) Loosen the fixing screw (1) and mount the non operation side flat spring on the operation side.

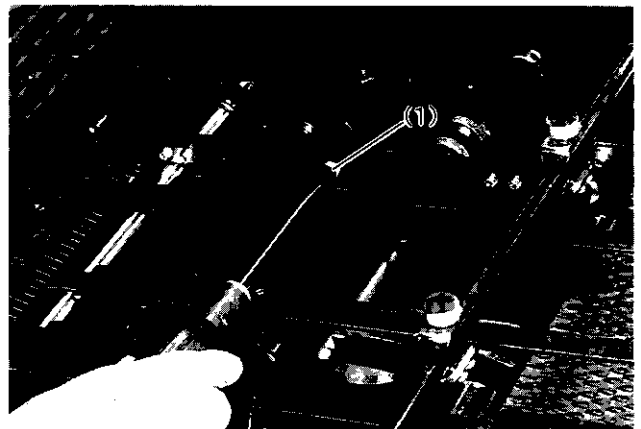

- 2) Remove the push guide device fixing screw (1) on the operation side.

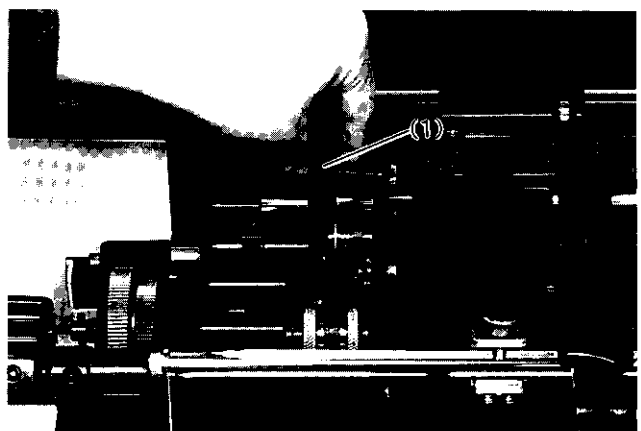

- 3) Mount the screw (1) in the push guide device on the non operation side and fix it and then loosen the screw (2).

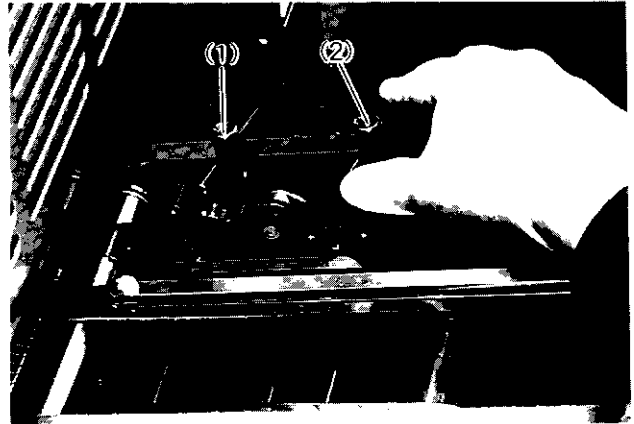

- 4) Loosen the screw (1) and move the push guide cam (2) in the condition where the non operation side pull guide device is pushed toward the frame side. At this time, contact the pin against the non operation side stopper exactly. Finally fix the screw (1).

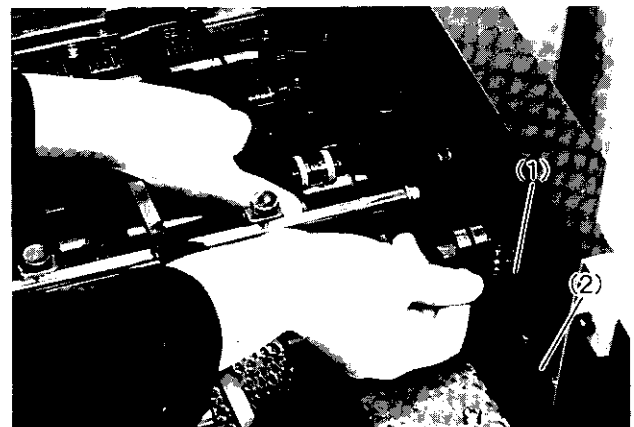
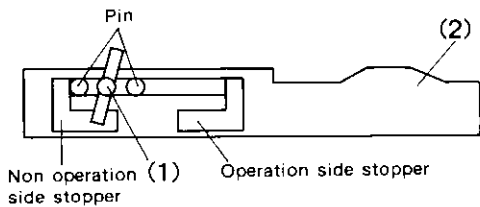

- 5) Remove the fixing screw (1).

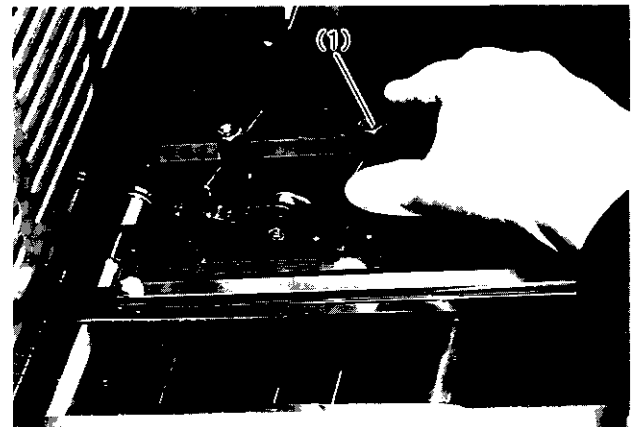

- 6) Mount the fixing screw on the operation side push guide device.

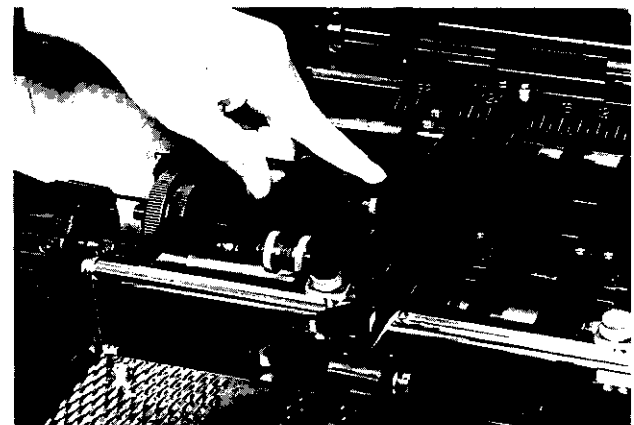

### B. Position Adjustment of the Board Tapes

Adjust the position of the board tapes. Set the 2 outer tapes (1) at the position where they are about 1 mm away from the flat spring (2) and the jogger guide (3). At this time, set the jogger guide (3) at its fully in position. Set the other inner board tapes so that they are spaced at equal intervals.

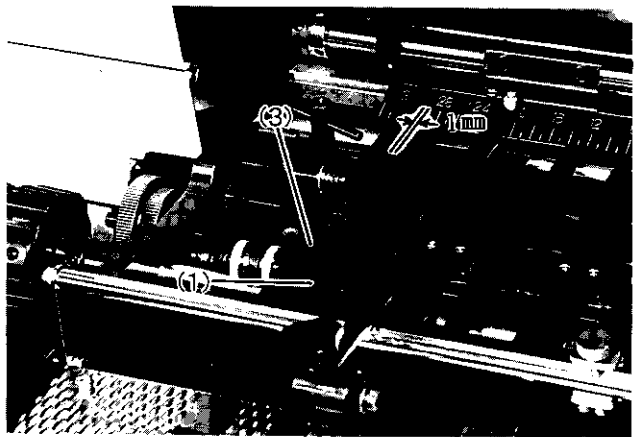
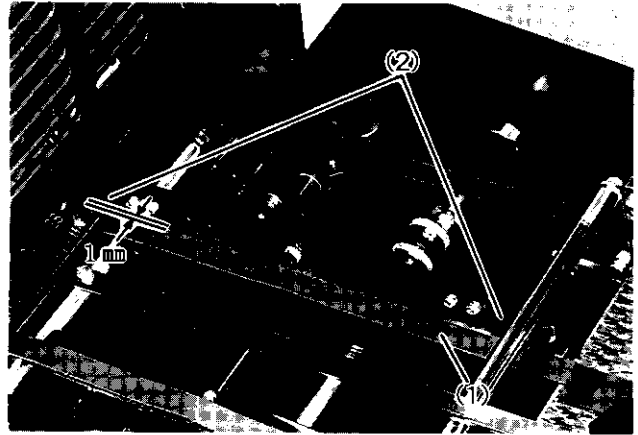

When moving the board tape (1), first loosen the board tape tensioner lock nut (2), then move it.

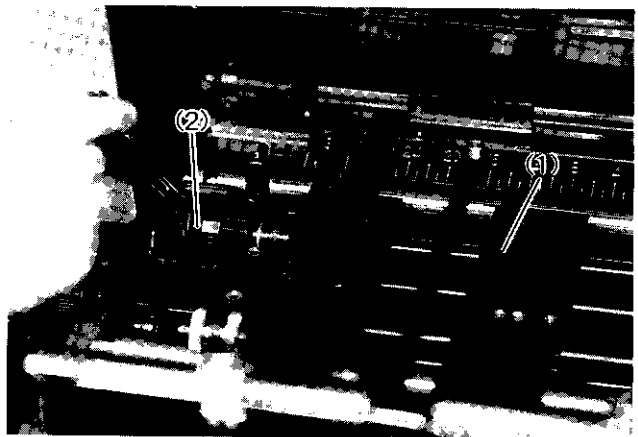

Note) When positioning the board tapes do not cover the photo sensor (2).

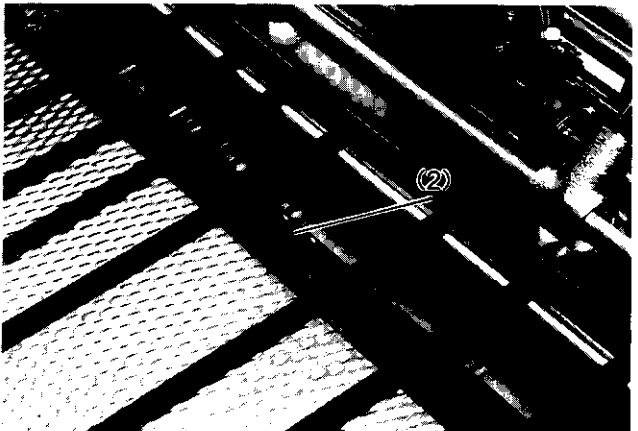

### C. Setting the Retainers

- 1) Mount the retainers on the pullout roller shaft (1) and on the feeder board shaft (2).

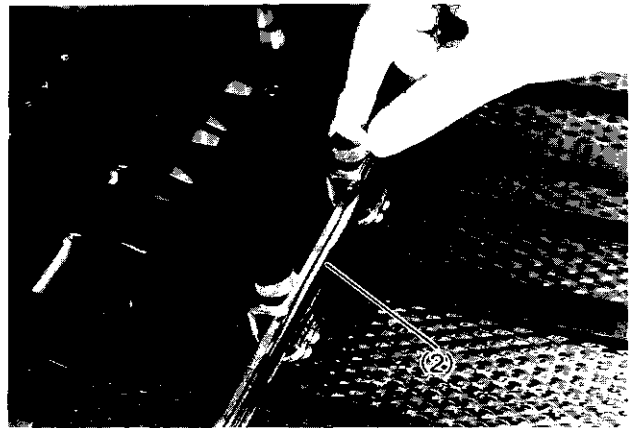
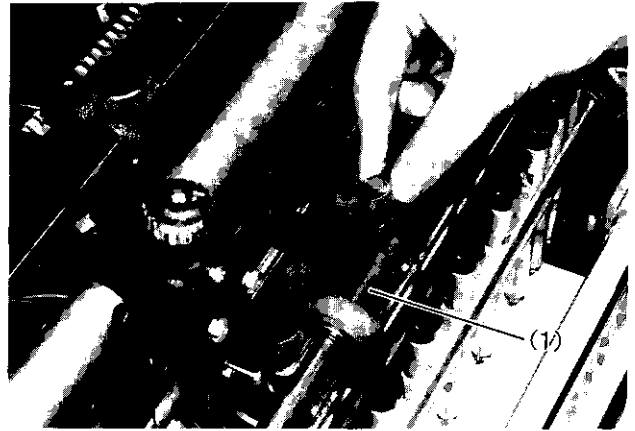

- 2) Mount the retainers on the board tapes.  
Mount the retainers on both the outer tapes every time.

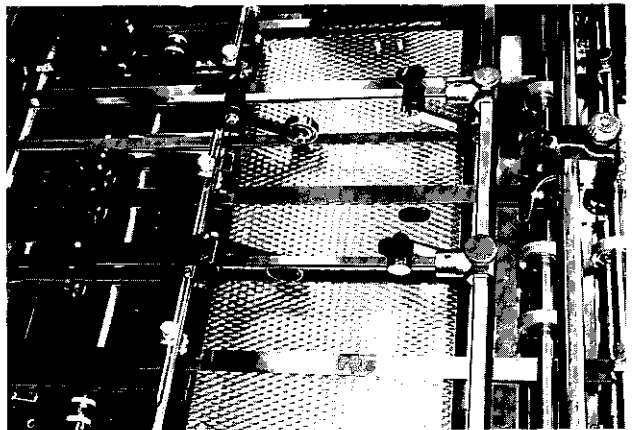

### D. Setting the Skid Rollers

- 1) Set the skid roller (1) on the two board tapes (2) that do not have retainers mounted.

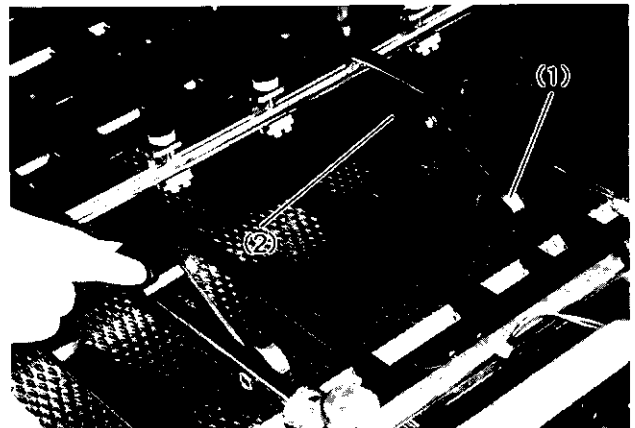

- 2) Adjusting the position of the skid rollers  
 With the paper at the paper stop finger (1),  
 loosen the screw (3) to position the center of  
 the skid roller (2) from 0.5 to 1.0mm behind the  
 tail edge of the paper.

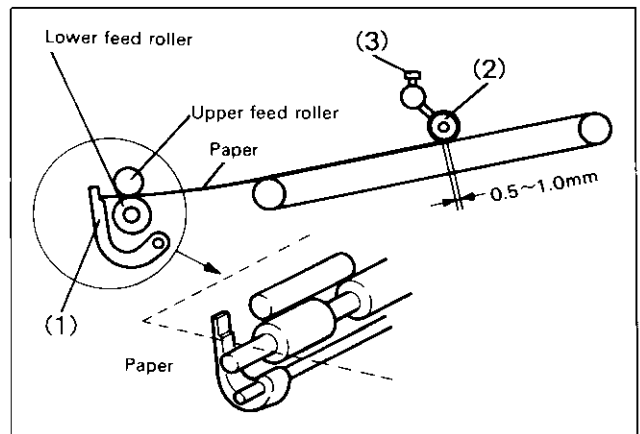
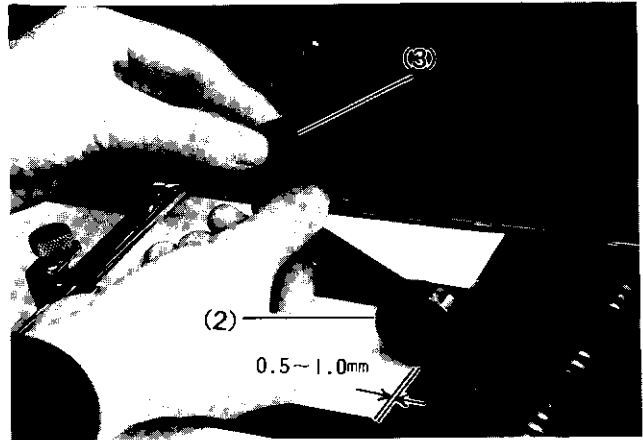





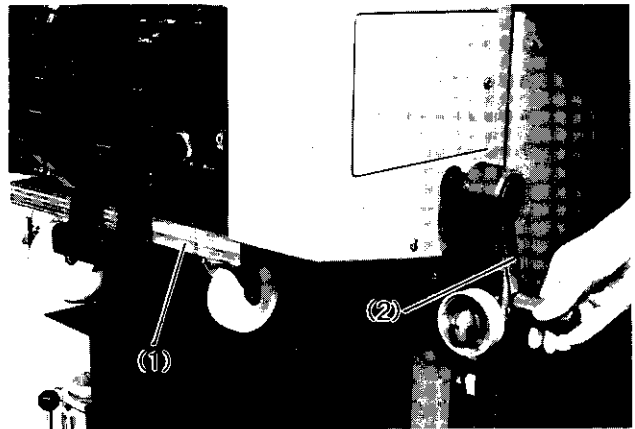

## 1-4 Setting the Delivery Section

### A. Setting the Delivery Guides

- 1) Set the delivery table dolly (1) and raise the delivery table dolly by using the delivery crank handle (2).



- 2) Push the crawl speed button  , the drive button  , and the pump button  . Shift the feed lever to the  position and feed one sheet of paper.

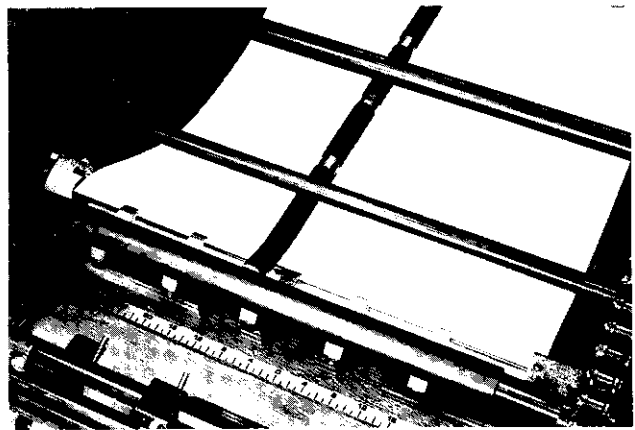

- 3) Feed the sheet of paper up to the delivery section and stop the machine. Then loosen the knob (1) and set the delivery stationary side guide (2) at the position 3mm away from the side of the sheet of paper.

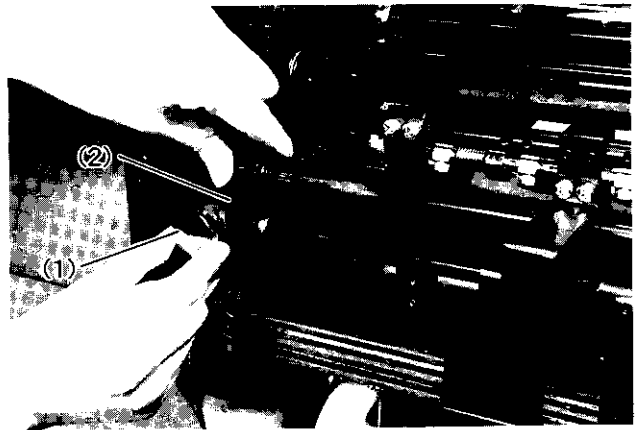

- 4) Deliver the sheet of paper onto the delivery table so the paper contacts the delivery stationary side guide (1) and the front guide (2). Then rotate the machine using the forward inching button and stop when the delivery jogger side guide (3) and the back guide (4) are moved fully in to the sheet of paper. Adjust each so that both lightly contact the sheet of paper. To set the delivery jogger side guide, loosen the knob (5) and move it and then fix the knob.

(Reference)

Adjust the paper drop (6) position depending on the size of the paper being printed.

(See P. 86)

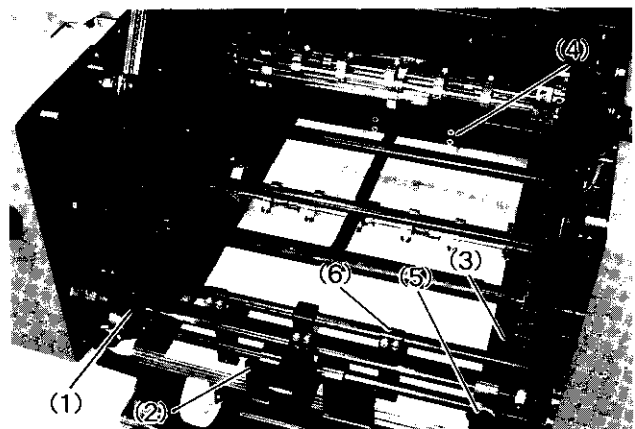

To set the back guide (4) loosen the lock knob (6) and turn the positioning knob (7) to position it and then fix the lock knob.



**B. Delivery Air Blower Control**

- 1) Control the blower volume so that the whole sheet of paper drops at the same time. When screwing in the control knob (1), the blower volume will become stronger.

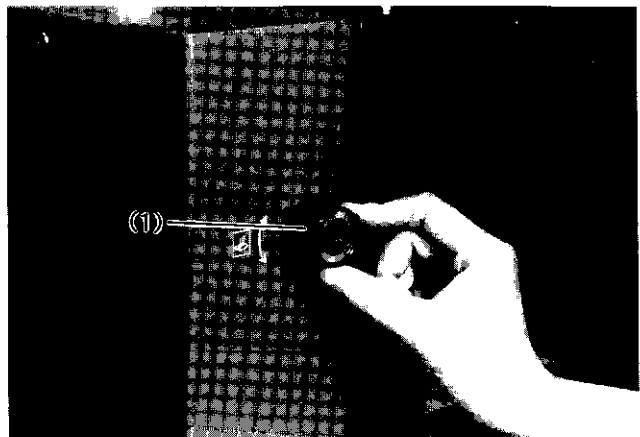

**[When the blower volume is weak]**

The leading edge of the printed sheet of paper will curl downward causing poor paper piling.

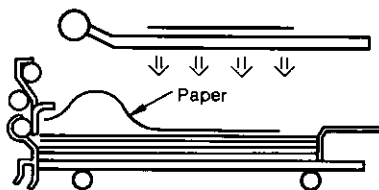

**[When the blower volume is strong]**

The leading edge of the printed sheet of paper will curl upward causing poor paper delivery.

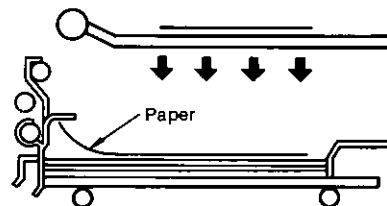

- 2) The delivery air blower nozzle can be opened or closed by using the sleeve (1).

When printing on minimum size paper, close the delivery air blower nozzle. Adjust the opening and closing of the delivery air blower nozzle depending on the condition of the printed paper.



## 1-5 Setting the Ink Section

### A. Setting the Ink

- 1) Set the ink form roller release lever (1) on the  position.

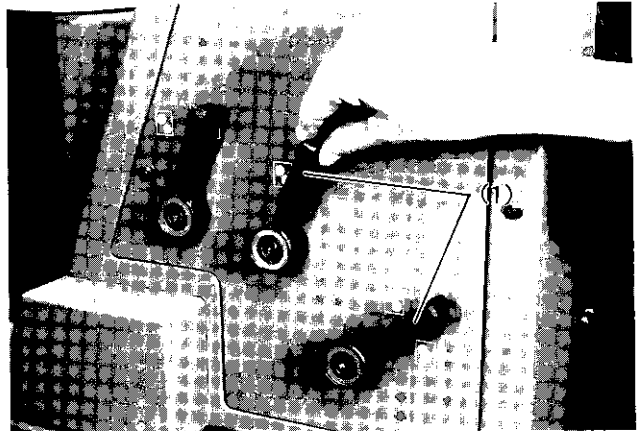

- 2) Wipe out the ink fountain and push the ink fountain (1) against the fountain roller (2) and put the fixing knobs (3) in the blackets (4). Then screw in the knobs (3) to fix the fountain (1).

Note) If the fountain roller (2) is rotated with no ink in the ink fountain (1) the fountain roller may be damaged.

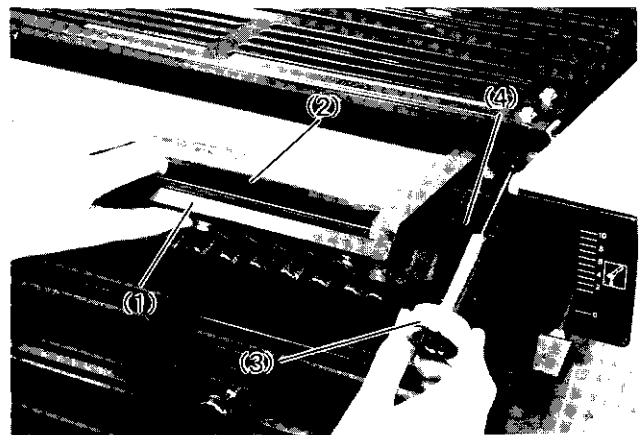



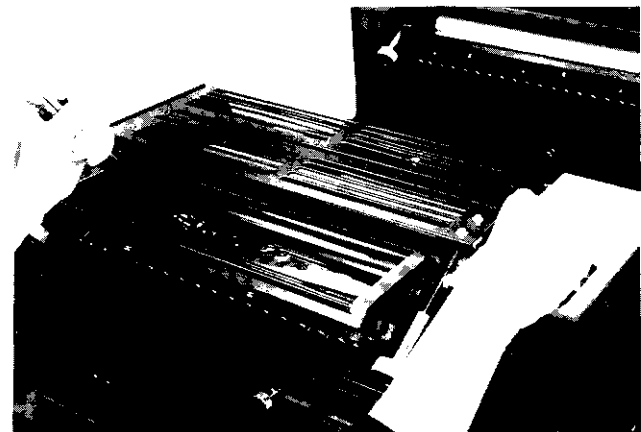

- 3) Put ink in the ink fountain.

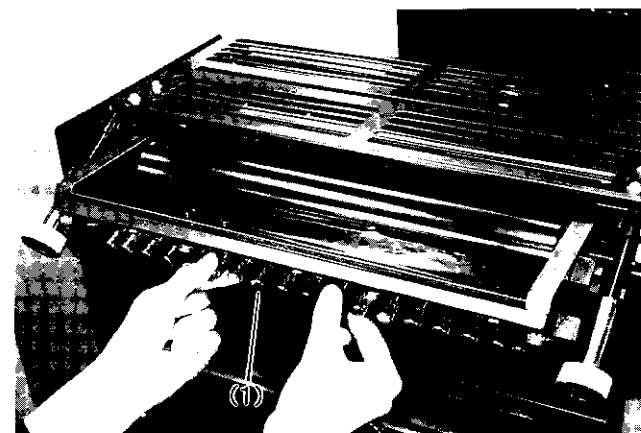

### B. Control the Ink Feed

- 1) Control the ink feed volume by using the screws (1) to match the image. When turning the screw (1) in the clockwise direction, the ink feed will be reduced.



- 2) Set the ink ductor roller switch  at the  position and push the drive button  and push the 7,000 speed setting button  to feed the ink onto the rollers.

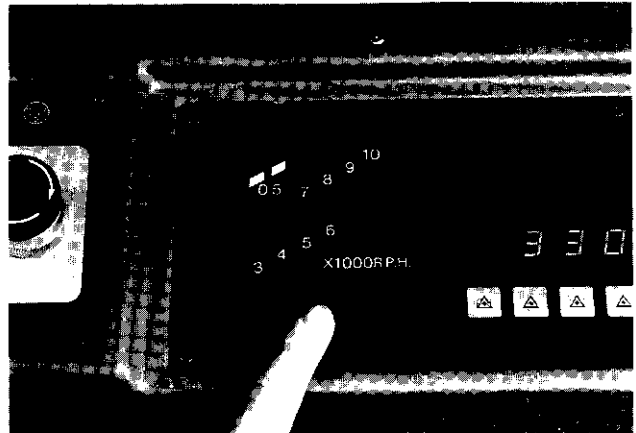

Control the total ink feed volume by using the control lever or the control dial.

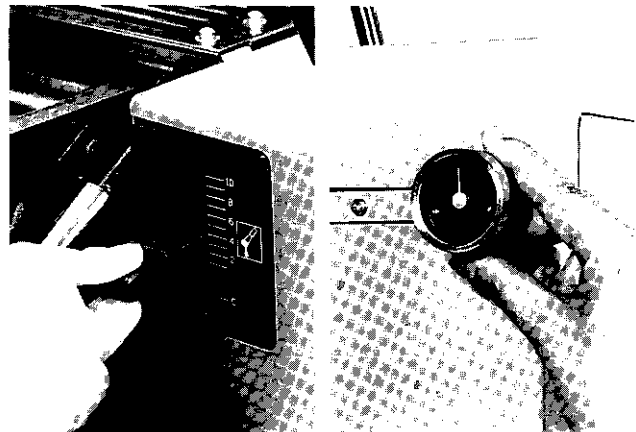

## 1-6 Setting the Blanket Cleaning Section (Optional Accessory)

### A. Setting the Blanket Cleaning Device

- 1) Put the blanket cleaning solution in the cleaning tray. Put the blanket cleaning solution in the bottle (1) and mount it on the bracket (2).

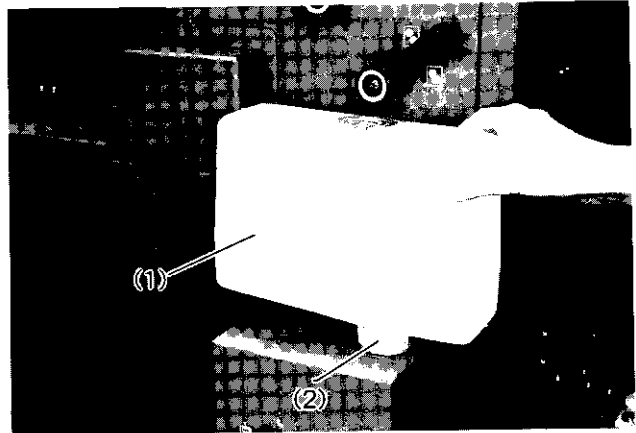

- 2) When shifting the ON/OFF lever (1) to the  position, the blanket cleaning solution will be fed into the tray. Keeping the lever in this position the blanket cleaning solution will be kept at a fixed level in the tray until the blanket cleaning solution bottle is empty.

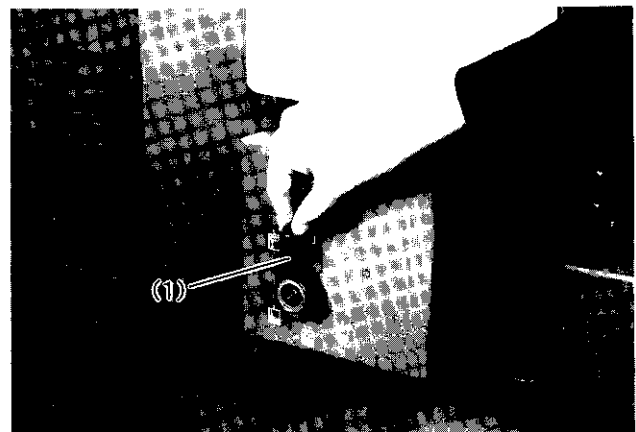

- 3) Set the waste solution bottle (Large Can). When shifting the ON/OFF lever (1) to the  position, the solution in the tray will be drained into the bottle.

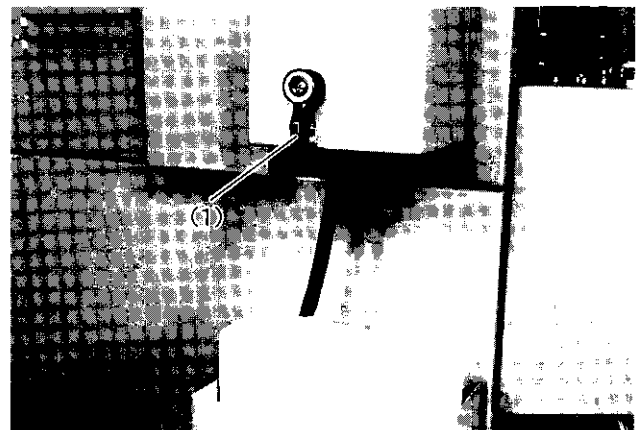

- 4) Set the blanket cleaning counter.

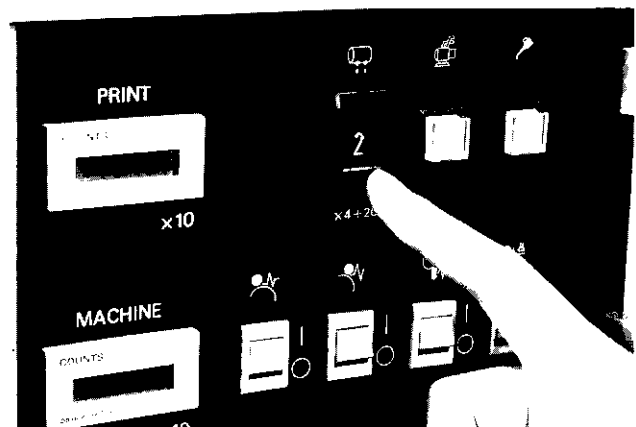

# Chapter 2

## Printing

### 2-1 Test Printing

#### A. Impression Pressure Adjustment

- 1) Measure the thickness of the paper by using a micrometer.

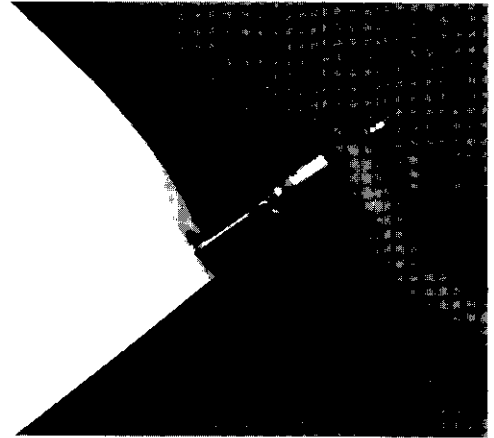



- 2) Set the impression pressure dial to match the paper thickness. Align the dial scale to the paper thickness.







#### B. Test Printing

- 1) Clean off the gum solution on the plate surface using water.

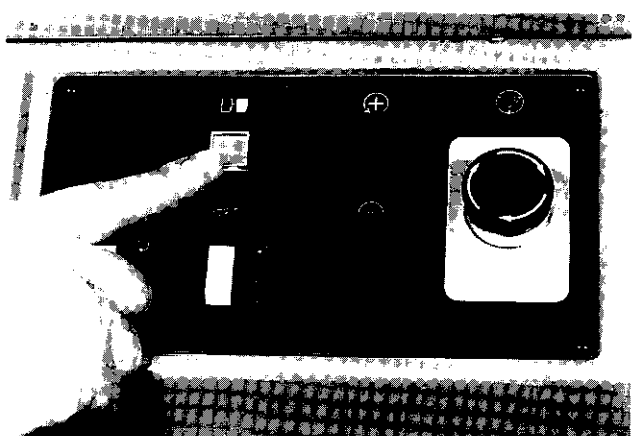

- 2) Push the printing button  on the unit that will be used for printing and the drive button  to operate the machine.



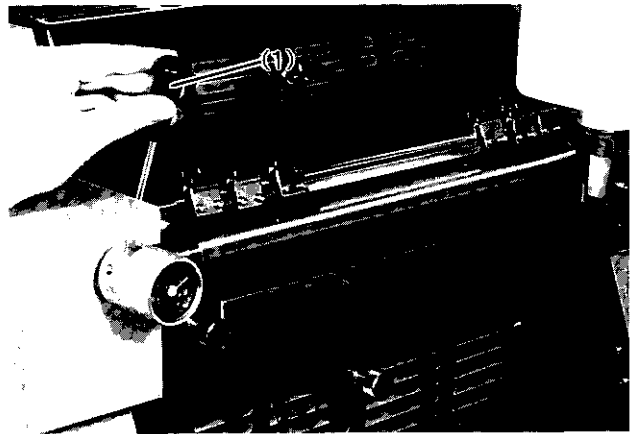

- 3) Set the water ductor roller switch  at the  position and manually turn the water fountain roller lever (1) and after feeding the dampening solution to the water rollers properly, set the water ductor roller switch  to the  position.



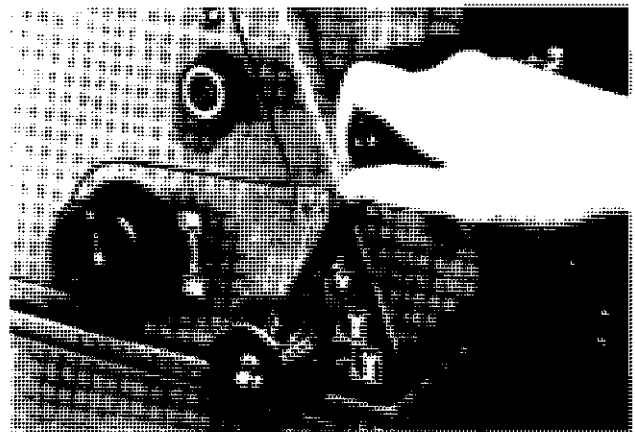

- 4) Shift the operating lever to the position  and feed the dampening solution and the ink onto the plate.

Note) At this time if the plate surface starts to scum, supply the dampening solution to the part of the water rollers that are stained using the squeeze bottle.

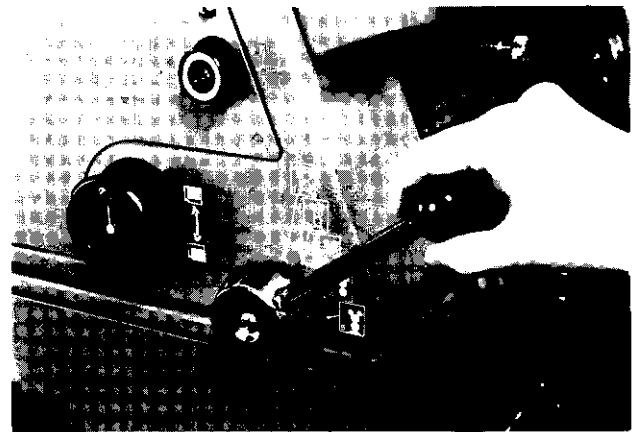

- 5) Set the operating lever at the  position, and transfer the image onto the blanket and then set the operating lever at the  position.



- 6) When setting the operating lever at the  position, the paper feed will start. When doing test printing, return the operating lever to the  position to stop the machine and then check the image position.

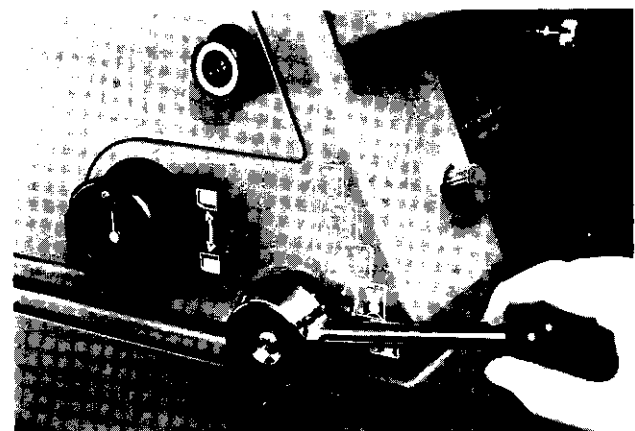

### C. Adjustment of the Image Position

First do the image position adjustment on the first unit, then do the image position adjustment on the second unit to match the position on the first unit.

#### [Vertical Adjustment]

- 1) Engage the vertical image adjustment dial (2) by pushing the clutch lever (1) down. With the clutch lever lowered, when releasing your hand from the clutch lever (1), the adjustment dial (2) is locked and the vertical adjustment of the image can be done.

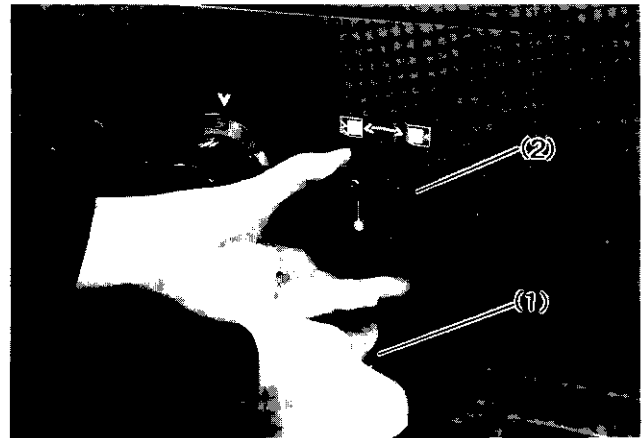

- 2) Turn the vertical image adjustment dial (1) and do the vertical position adjustment of the image.

When turning the adjustment dial (1) in the + direction, the image will move toward the leading edge side.

(Reference)

Moving the adjustment dial (1) by one scale moves the image 0.5mm.

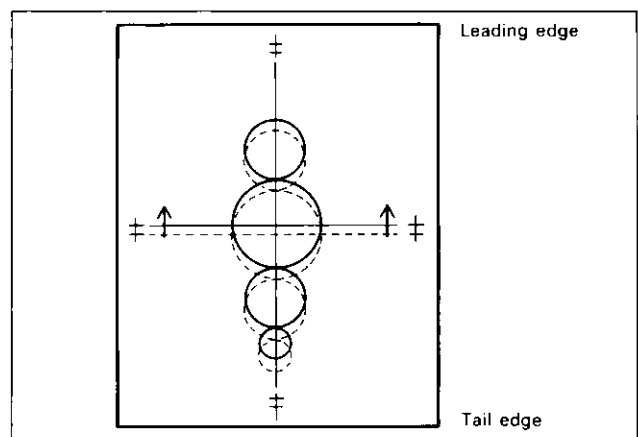
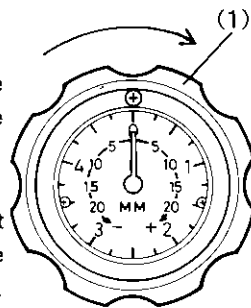

- 3) Push the clutch lever (1) down again to release the adjustment dial (2) lock.

Note) When the vertical image adjustment dial is locked, a safety device actuates so that the machine cannot be operated.

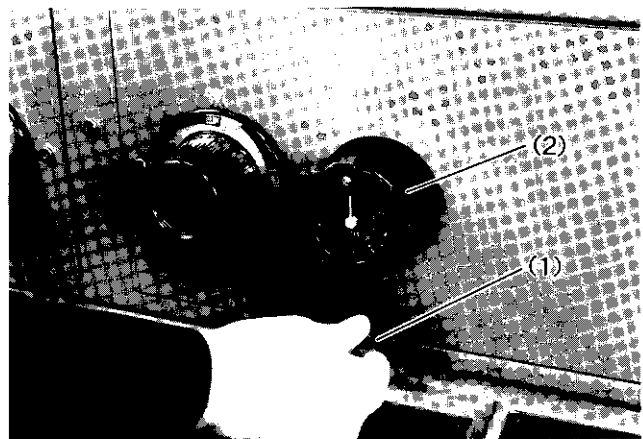

#### [Lateral Adjustment]

- 1) Turn the lateral image adjustment dial and adjust the lateral position of the image on the first and the second units.

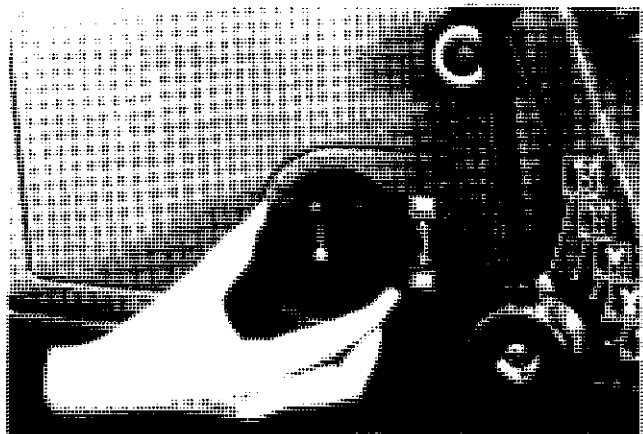





When turning the adjustment dial (1) in the clockwise direction, the image will move toward the operation side.

(Reference)

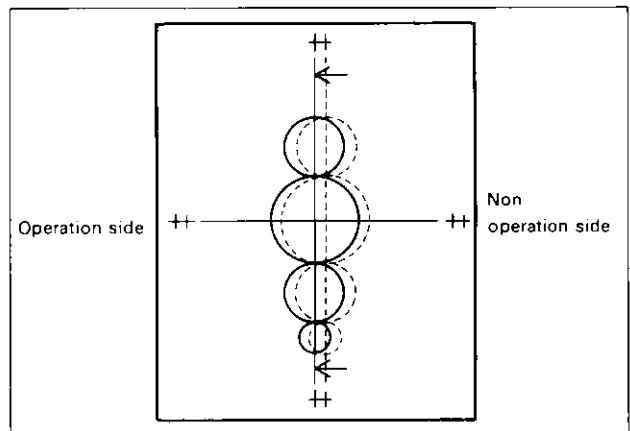
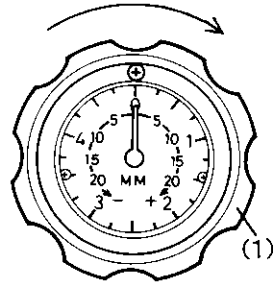
Moving the adjustment dial (1) by one scale moves the image 0.2mm.



Note)

1. During printing or with the operating lever on the  position, do not turn the adjustment dial.

2. The adjustment range of the lateral image adjustment dial is  $\pm 2$ mm. If the image cannot be adjusted between this range adjust the push side lay position (P. 64) and the paper feed position (P. 57) again.



**[Diagonal Adjustment]**

The diagonal adjustment of the image is done by moving the plate clamp.

Example) When diagonally moving the image at the operation side toward the leading edge.

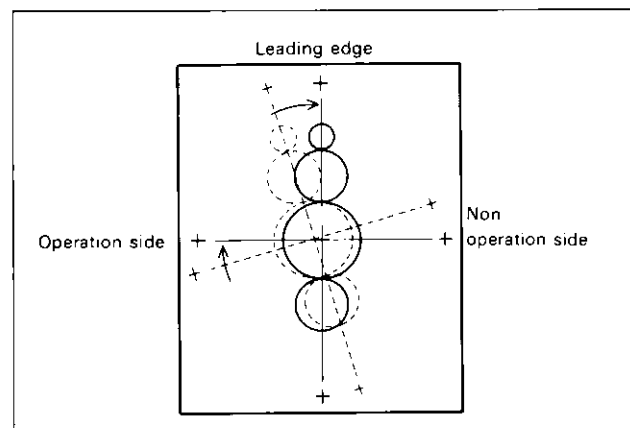

- 1) Loosen the tail edge plate tension bolts (1).
- 2) Loosen the plate by turning the quick tension bolt (2).

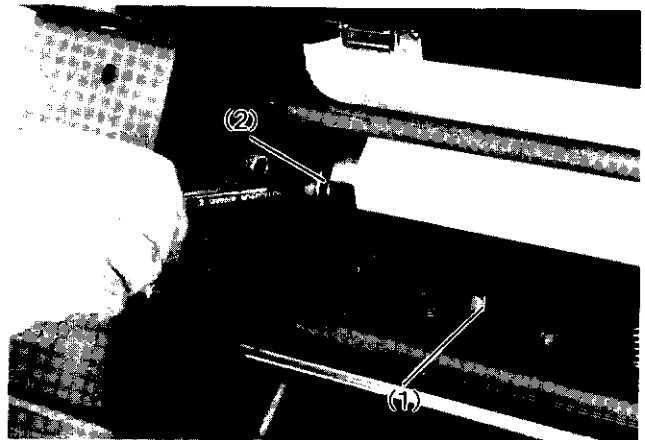

- 3) Screw in the bolt (3) and move the operation side leading edge clamp while reading out the correcting volume using the clamp positioning scale on the operation side.

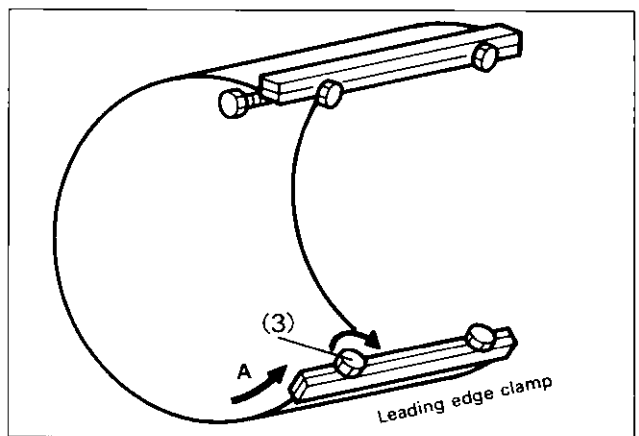
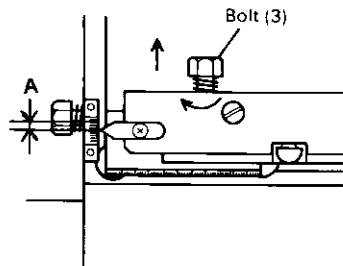

- 4) Turn the clamp lateral positioning adjustment bolt (4) and move the tail edge clamp toward the operation side.

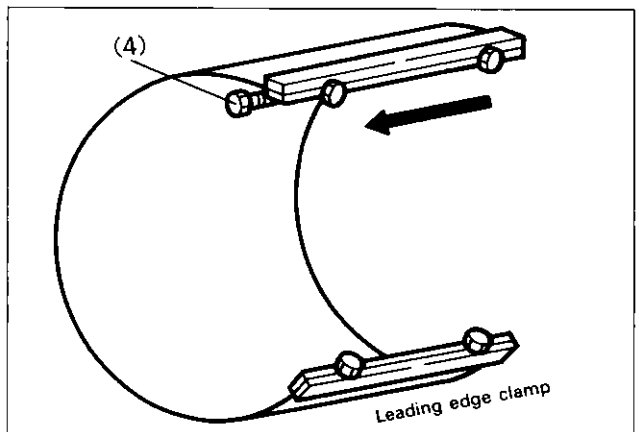

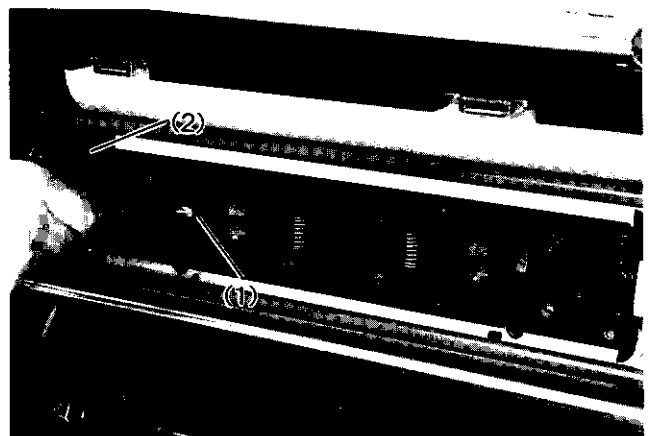

- 5) Tension the plate by using the quick tension bolt (2).
- 6) Fully tighten the tail edge plate tension bolts (1).



## 2-2 Printing

After finishing the position adjustment of the image, clean the blanket and start to do continuous printing.

### A. Setting the Counter

- 1) Push the clear button  (1) to set the counter to "0" and push the counter ON/OFF button . (At this time the counter ON/OFF button  lamp lights up.)

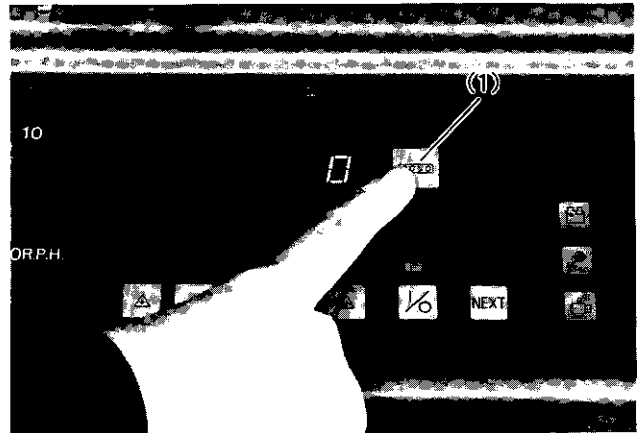



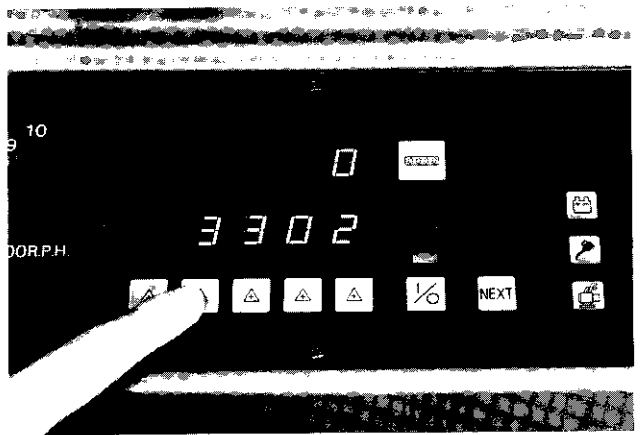



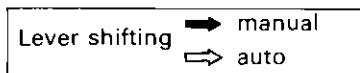

- 2) Set the number of printed sheets required.



### B. Printing

[Printing Process]





1. Push the drive button  .  
..... Machine starts .
2. Shift the operating lever to  .  
..... The dampening solution is supplied onto the plate surface.
3. Shift the operating lever to  .  
(Check that no scum appear on the plate surface.)  
..... The pump starts and the ink is supplied onto the plate surface.
4. Shift the operating lever to  .  
..... The image is transferred onto the blanket
5. Shift the operating lever to  .  
..... The paper feed and printing start
6. The set number of sheets of paper are printed.  
..... The paper feed stops.
7. The operating lever automatically returns to  .  
..... The blanket is cleaned.
8. The operating lever automatically returns to  .  
..... The machine stops.

### C. Powder Spray Device

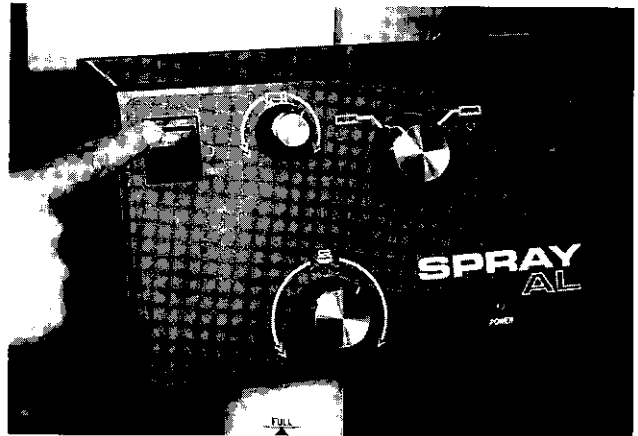
When setoff may be a problem, use the spray device. When setting the spray device ON/OFF switch at the  position, powder will be sprayed when a sheet passes under the spray nozzle.



- 1) Switch the spray nozzle to match the printing paper size.

When the paper size width is less than 220 mm, set the spray nozzle selection knob at the  position and when the width is larger than 220 mm, set it at the  position.



- 2) Adjust the powder spraying time during one machine rotation by using the spray time adjustment knob.

When turning it in the counterclockwise direction, the spraying time will be increased and the spraying area will be wider.

When adjusting the spraying time, do it while checking the lamp on the spray unit.



- 3) Adjust the powder spraying volume by using the spray volume adjustment knob.

When turning it in the counterclockwise direction, the spray volume will be increased.

To prevent possible trouble, please adjust the spray volume to keep it at the minimum necessary.



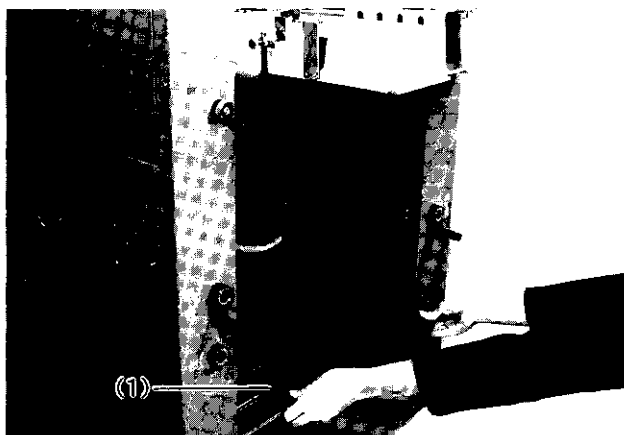

### D. Pre-pile System

- 1) When the number of sheets of paper on the feed table is reduced set the other feed table (1).

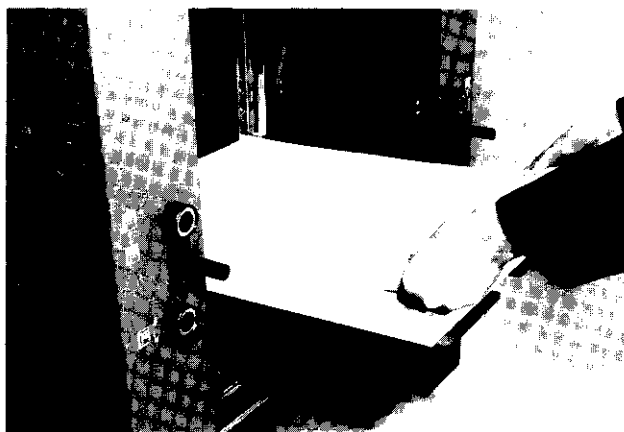

- 2) Set the paper pile board and pile the paper.



- 3) After the first paper pile is all printed, set the feed lever (2) and the  position.

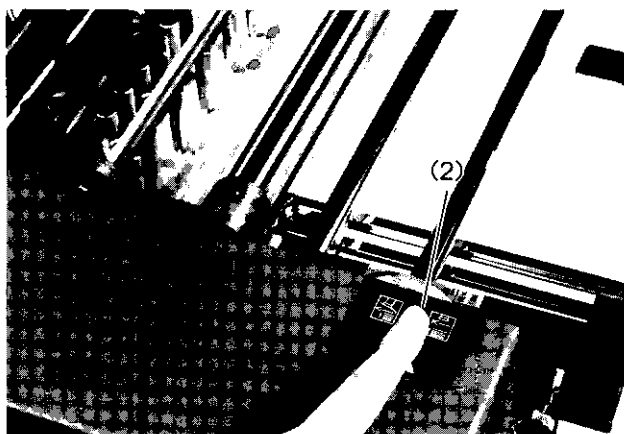

- 4) Set the release lever (3) at the  position.

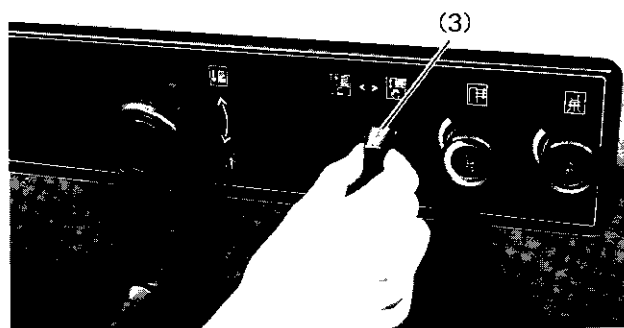

- 5) Flip up the guide bar (4) and remove the paper pile board.

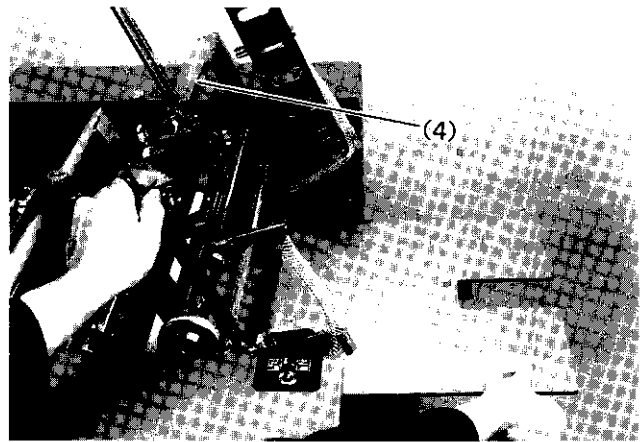

- 6) Lift the lever (5) and remove the paper feed table (6).

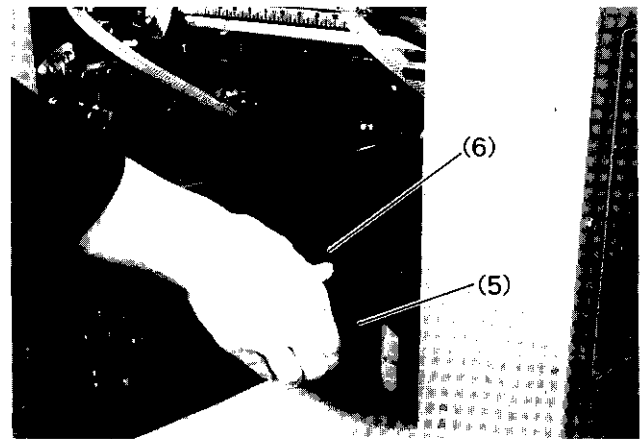

- 7) Raise the second pile by using the paper feed crank handle (7).



- 8) When the height of the paper pile properly positioned set the feed lever (2) at the  position and start the printing again.

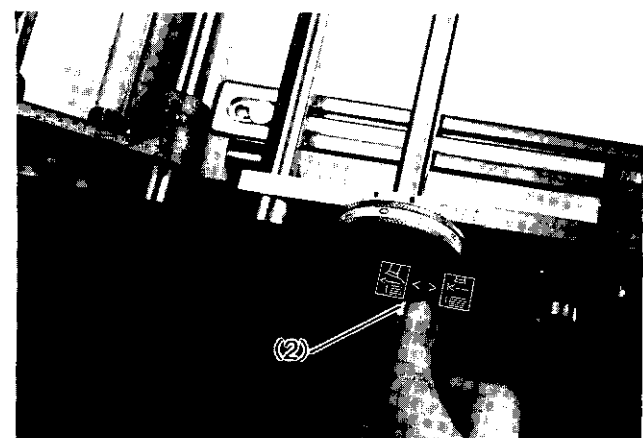

# Chapter 3

## Printing Practice

### 3-1 Minimum Size Paper (90×130mm)

#### Printing

#### (Point)

#### A. Setting the Paper Feed Section

- 1) Pile the paper on the paper feed table with the center of the sheets (postcards, etc.) positioned 5mm from the center on the operation side (line A).

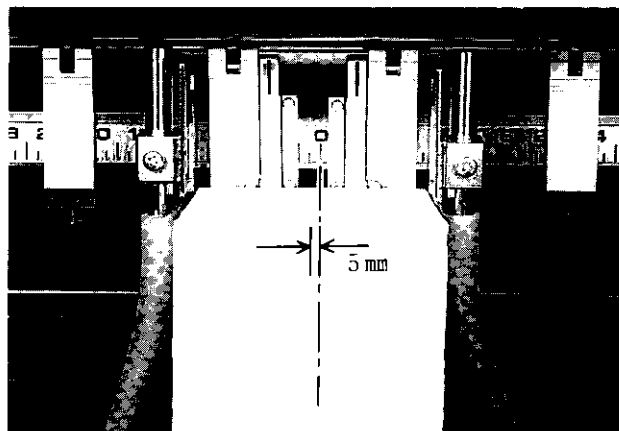

- 2) Use the two center sheet separators (1).

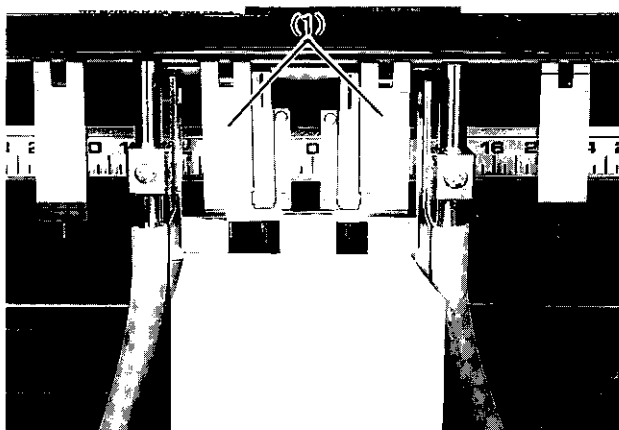

- 3) Set the side guides and the back guide.

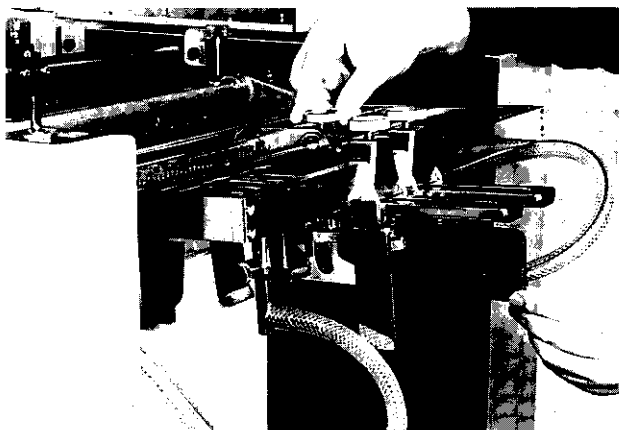

- 4) Set the pullout rollers (1) on both sides of the double sheet detector (2) (between the suction feet) and stop the vacuum of the suction feet not going to be used. Use the two central suction feet.

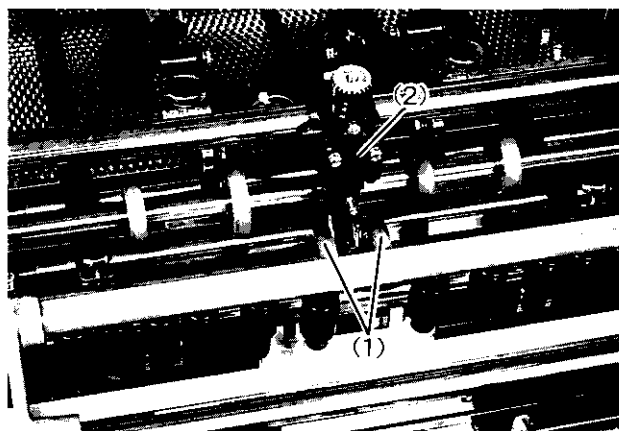

**B. Setting the Push Guide Device**

- 1) Loosen the board tape tension lock and lift the tape up and then pass the push guide device under it.

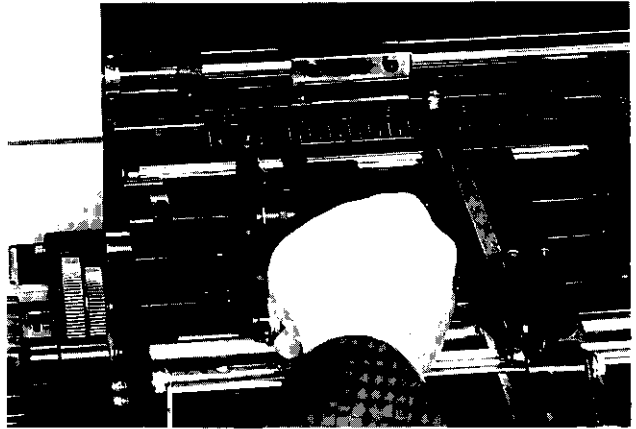

- 2) Use the four board tapes (1) on the non operation side and shift the remaining one tape (2) to the operation side.

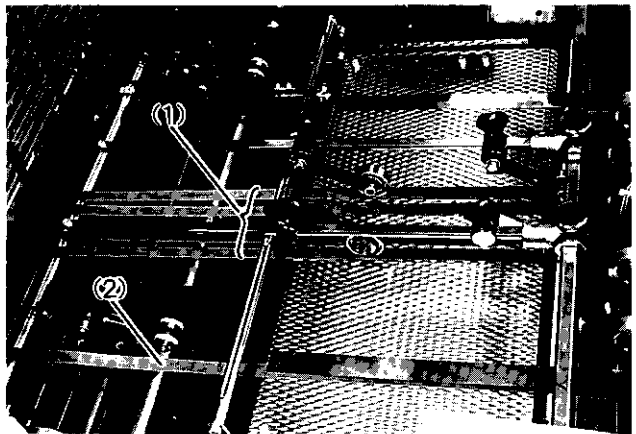

- 3) Set the push side lay and the flat spring. Change the mounting position of the flat spring.

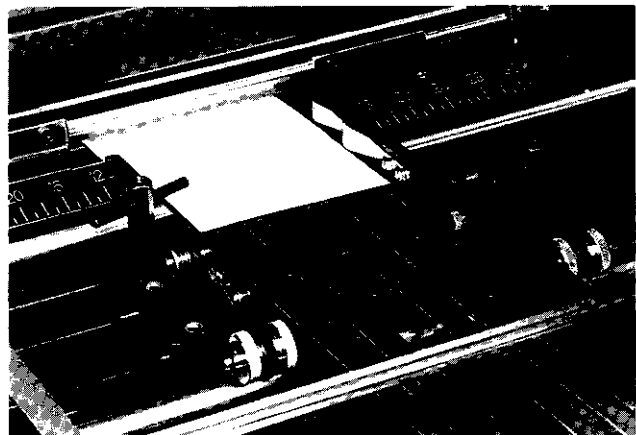
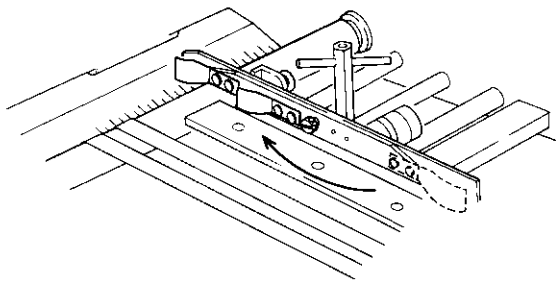

- 4) Set the skid rollers (1) at the tail edge of the paper.

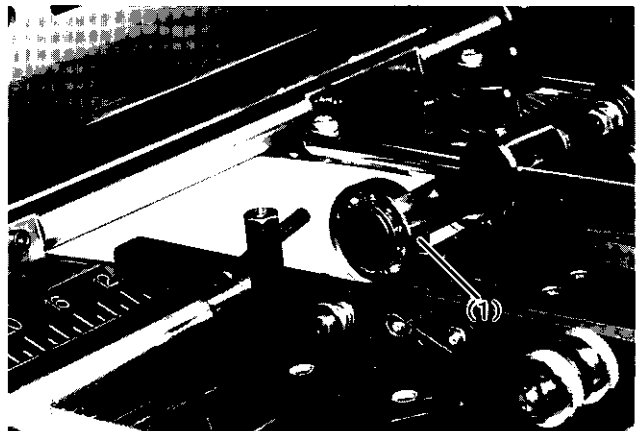



### C. Setting the Delivery Section

- 1) Set the minimum size paper delivery guide (1) on the delivery back guide and insert the hitch pin clip (2) on the guide so the guide will not come off during the machine operation.

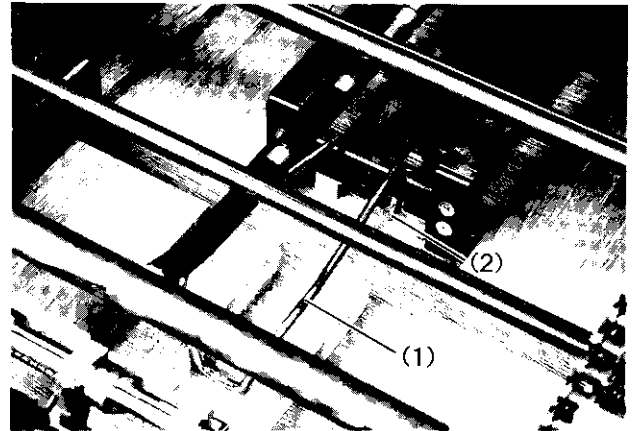

- 2) Paper drop  
Move the paper drop inward depending on the size of the sheet being printed.

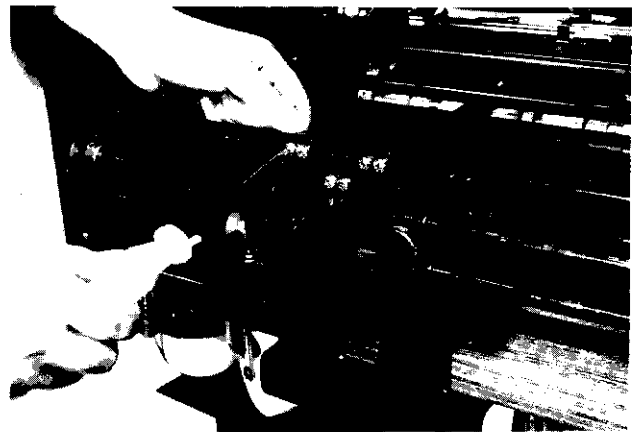

### D. Image Position

The image should be reproduced at the position shown in the illustration.

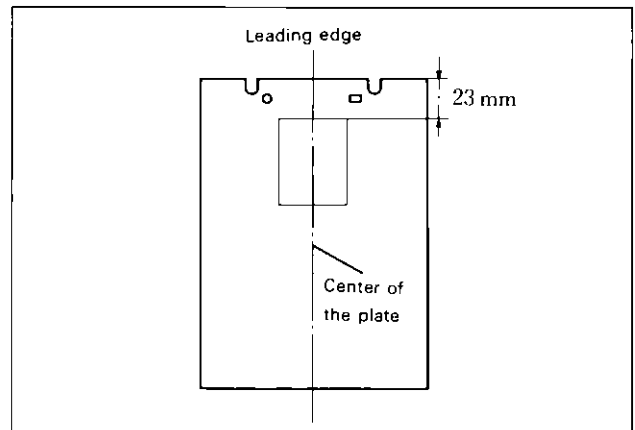

### 3-2 Thin Paper Feeding (Paper with a thickness less than 0.08mm)

(Point)

#### A. Paper Feed Pile Height

Adjust the paper feed pile height for the thin paper  
(See P. 59)

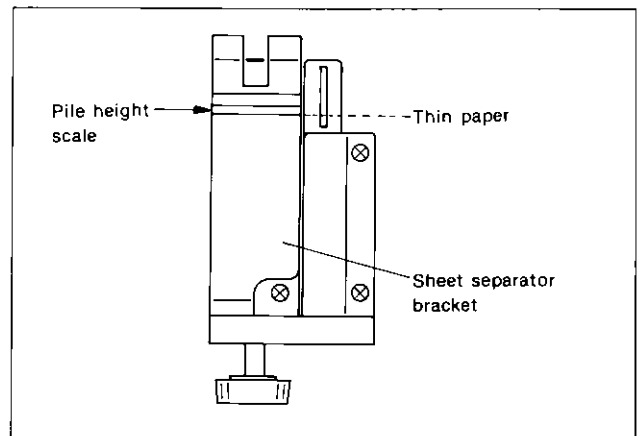

#### B. Setting the Suction Feet

Please do not use the rubber suckers.

#### C. Vacuum Control

Control the vacuum to be as weak as possible.  
If the rubber suckers or strong vacuum is used, the paper will be squeezed by the suction feet and will not be fed straight up to the pullout rollers.

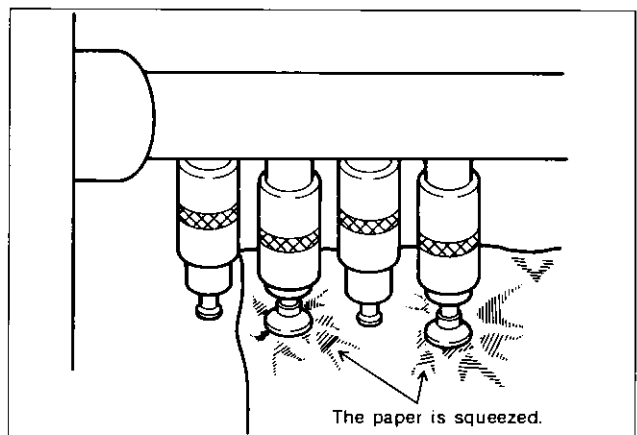

#### D. Blower Control

Control the blower volume so that the top 5 to 6 sheets of paper are separated and so that the top sheet lightly contacts the sheet separator.

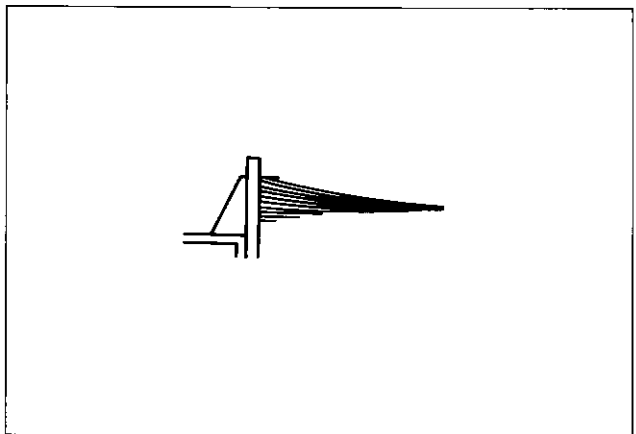

#### E. Auxiliary Side Blower Control

Control the back blower volume to separate the top 5 to 6 sheets of paper.

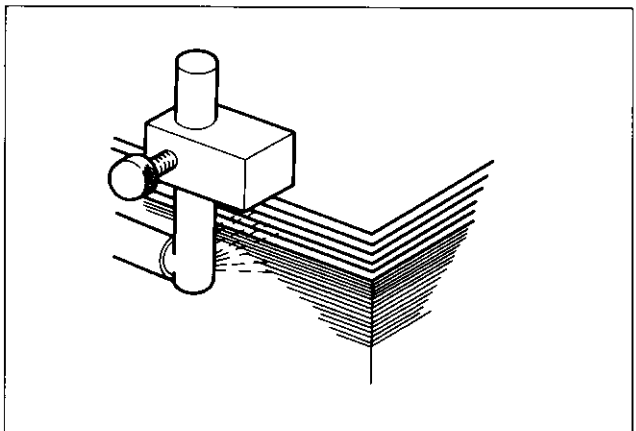

**F. Setting the Retainers**

Use the retainer for thin paper.

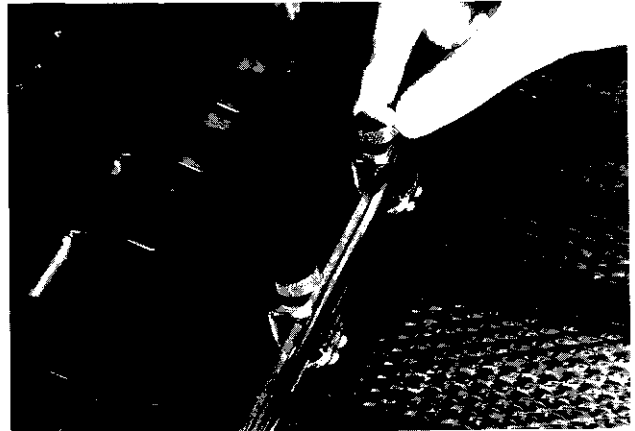

**G. Setting the Skid Rollers**

If the skid rollers are positioned too forward the sheet of paper will bulge as shown in the illustration.

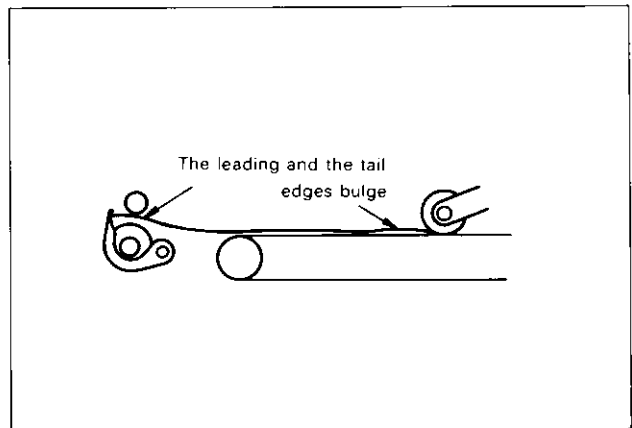

**H. Flat Spring**

Change the flat spring (1) on the feeder side with the one for thin paper.

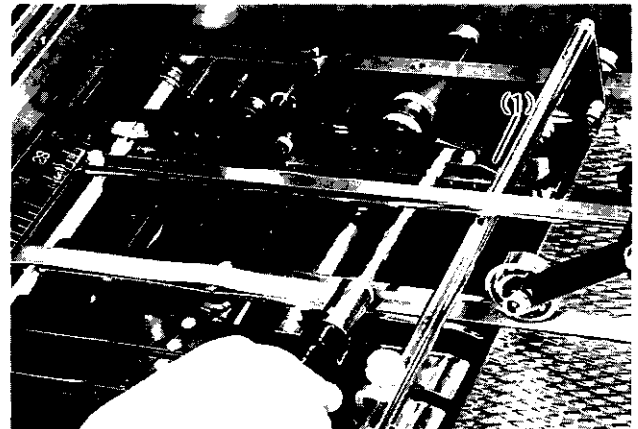

**I. Pushing Volume Adjustment**

When the paper is pushed by the push side lay, the flat spring (1) should bend about 0.5 mm.

Note) If the pushing volume is too great, the paper will bulge as shown in the illustration below and stable lateral registration accuracy will not be possible.

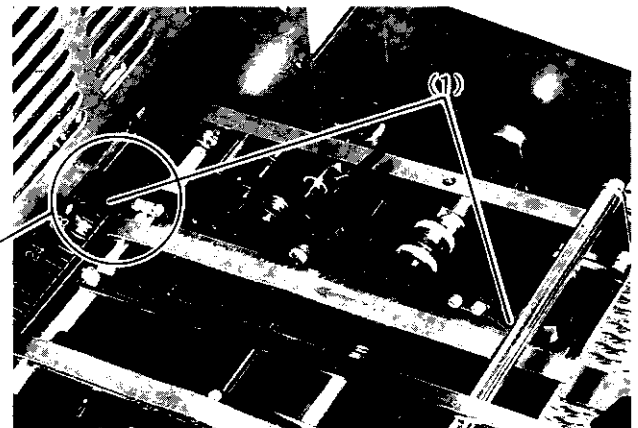
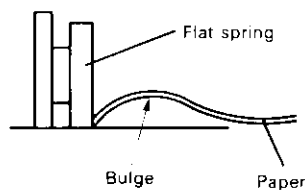

### 3-3 Paper Feed and Delivery of Curled Paper

(Point)

#### A. Paper Feed Section

- 1) Correct the curl of the paper and pile the paper.



- 2) Use wedges to make the top of the paper pile flat.

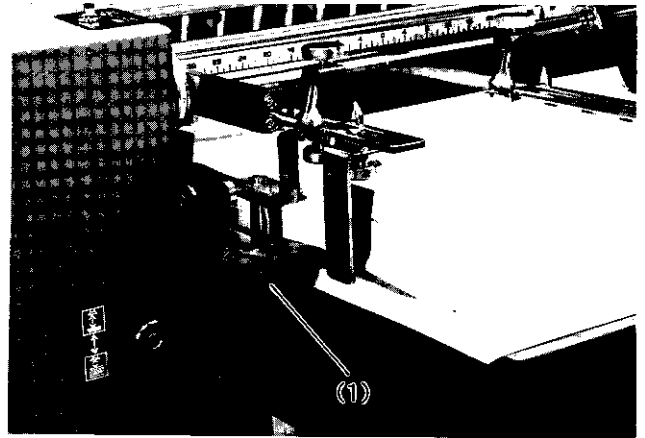

#### B. Delivery Section

- 1) Use wedges (1) and set the delivery air blower so that the whole sheet drops at the same time.

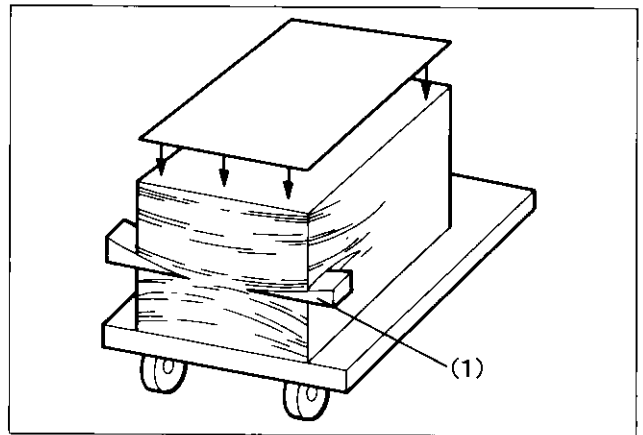

### 3-4 Single Color Printing

(Point)

#### A. Printing Button

Push the printing button on the unit that will not be used and keep the lamp light off. In this condition the cylinder will not go ON even when the paper is fed. (Printing cannot be done on this unit.)

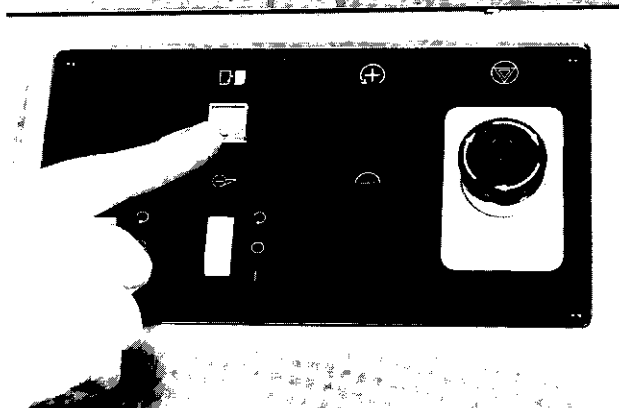

#### B. Removing the Rollers

When printing using only one unit for a long period, friction damage may occur to the rollers on the unit that will not be used. To prevent this follow the items 1) and 2) below.

- 1) Remove the rollers on the unit that is not being used. (The rollers that should be removed are shown in the illustration on the right marked with diagonal lines.)
- 2) Set the ink and the water form roller release lever at the  position to release the form rollers and the oscillating roller.

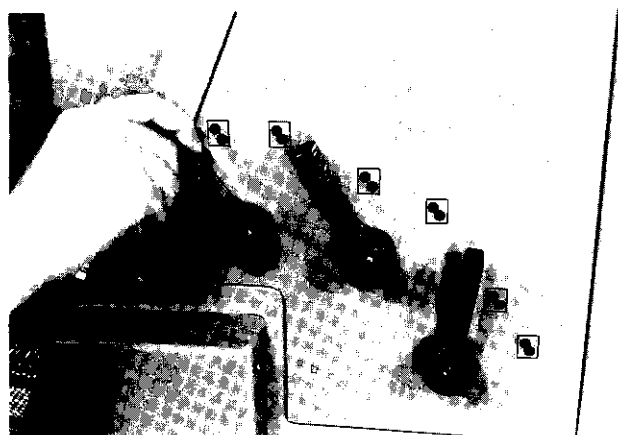
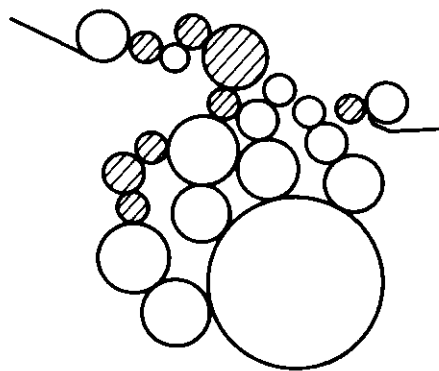

### 3-5 Troubleshooting during Printing

#### A. When the machine cannot be operated...

Check that all of the safety devices are not actuated and all of the safety covers are closed by checking the OK monitor lamps.

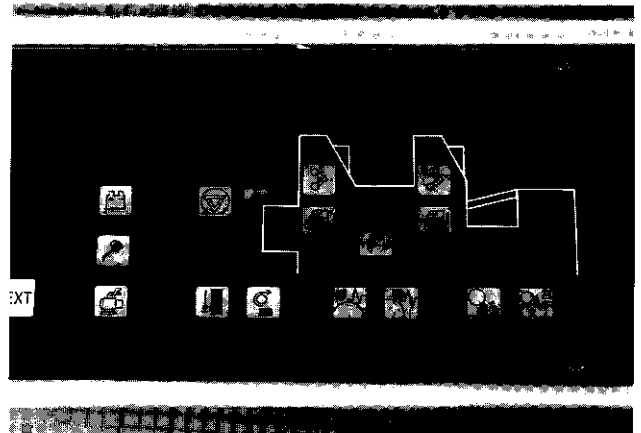

#### B. When the dampening solution feed volume is short...

Supply the dampening solution to the part of the water rollers where the plate surface is scummed using the squeeze bottle and at the same time increase the dampening solution feed volume by turning the water volume control dial toward a larger number.

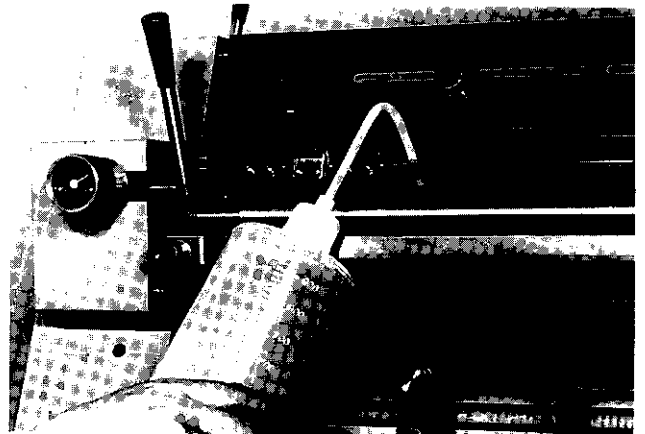

#### C. When the ink feed volume is short...

Manually turn the fountain roller to feed the ink onto the plate surface and at the same time increase the ink feed volume by moving the control lever or the control dial toward a larger number.

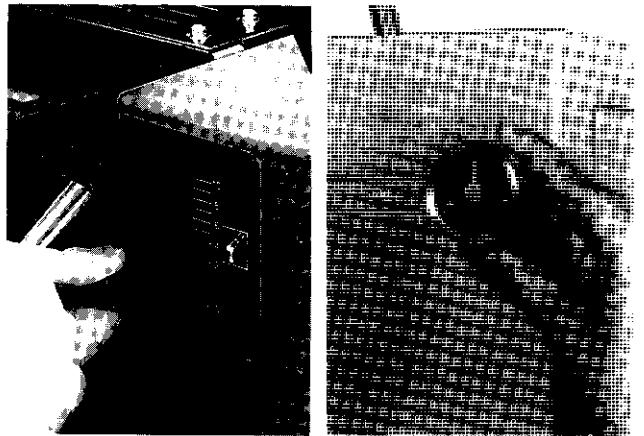

#### D. When the dampening solution feed volume (ink feed volume) is too much...

- 1) Set the ductor roller switch to the  position and stop the dampening solution feed (ink feed).
- 2) Reduce the dampening solution feed volume by turning the control dial toward a smaller number.  
Reduce the ink feed volume by moving the control lever or the control dial toward a smaller number.

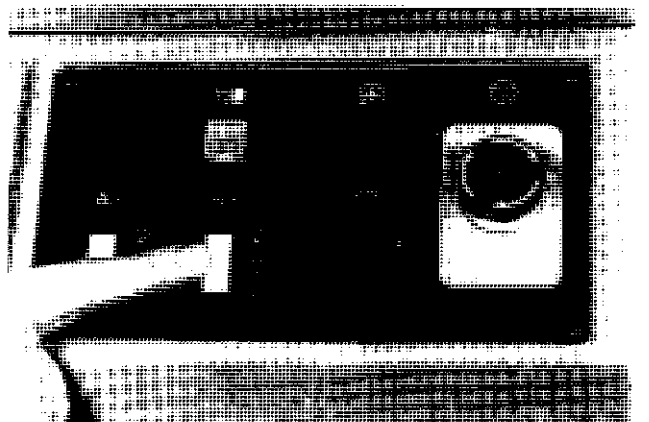

**E. When the paper feed delayed timing detector actuates...**

Return the operating lever to the  position and remove the delayed sheet of paper and then start the printing again.

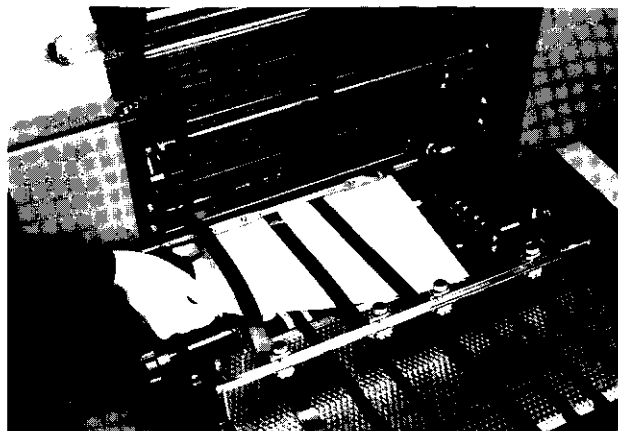

**F. When the feed jam detector actuates....**

Return the operating lever to the  position and remove the jammed sheet of paper and then start the printing again.



**G. When the blanket jam detector actuates...**

Return the operating lever to the  position and remove the jammed sheet of paper on the blanket and at the same time check that no sheet of paper is jammed on the ink rollers.

**H. When the delivery jam detector actuates....**

Push the emergency stop button and after checking that everything is safe remove the jammed sheet of paper then release the emergency stop button and start the printing again.



**I. When a power failure occurs during the printing...**

- 1) Return the operating lever to the  position.
- 2) Mount the handwheel and deliver the sheets of paper stopped in the middle of being printed. (When turning the cylinder one time, the blanket cylinder will separate from the plate cylinder and the impression cylinder.)
- 3) Clean the blanket and apply gum solution on the plate.

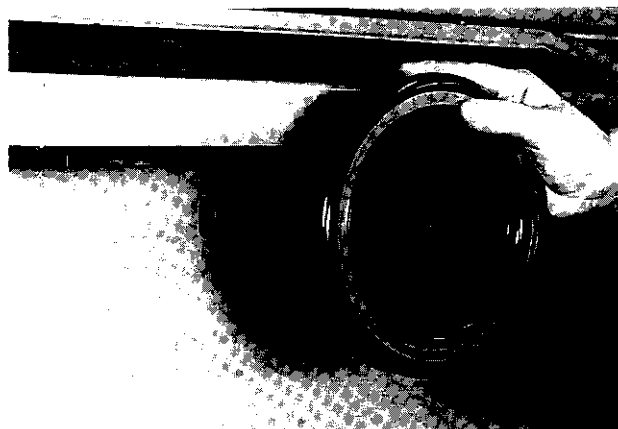

# Maintenance and Inspection

## 4-1 Care after Printing

Clean the machine everyday after finishing the printing to keep the machine in top running condition.

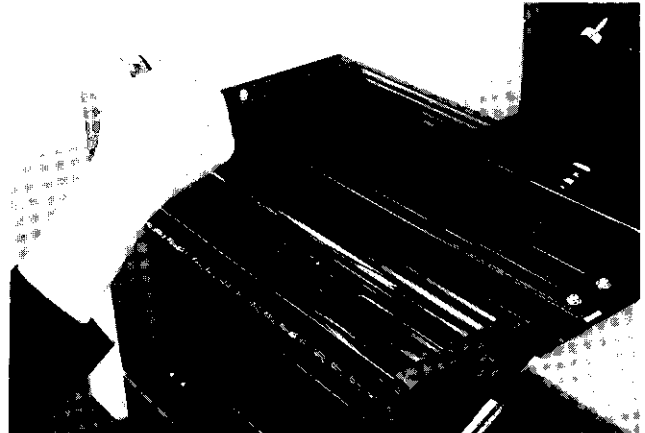

### A. Cleaning the Ink Rollers

1) Remove the ink in the ink fountain.



2) Clean off the ink on the ink fountain roller surface and the sides, the ink fountain, and the edge of the blade.



3) Set the ink ductor roller switch  to the  position and start the machine. Apply the roller cleaning solution on the rollers and shift the ink roller cleanup attachment lever in the direction of the arrow.

Note) When mounting the ink roller cleanup attachment, insert the pin of the ink roller cleanup attachment into the bracket pin hole exactly.

If it is not done when rotating the machine, the ink roller cleanup attachment will drop and this will cause an accident.

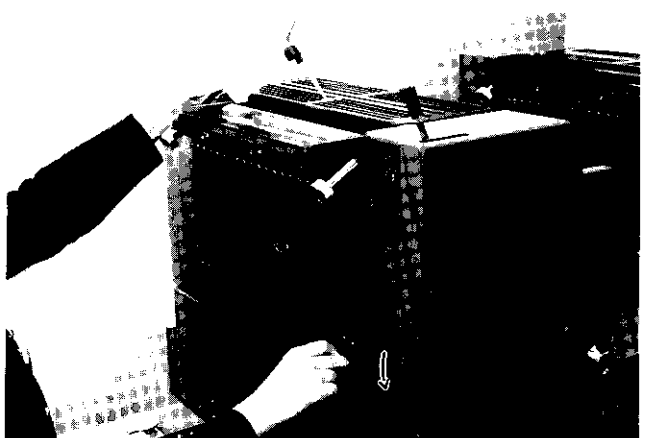



- 4) Push the 7,000 speed setting button **7** and clean the rollers.



- 5) After cleaning the rollers, shift the roller cleanup attachment lever in the direction of the arrow and then stop the machine.

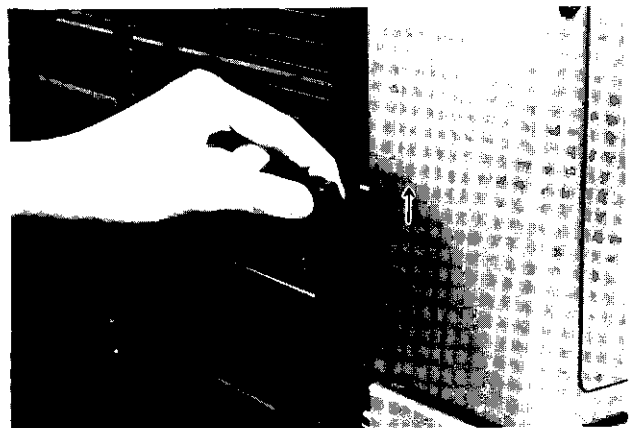

- 6) Wipe off any foreign particles and dust on the rollers.

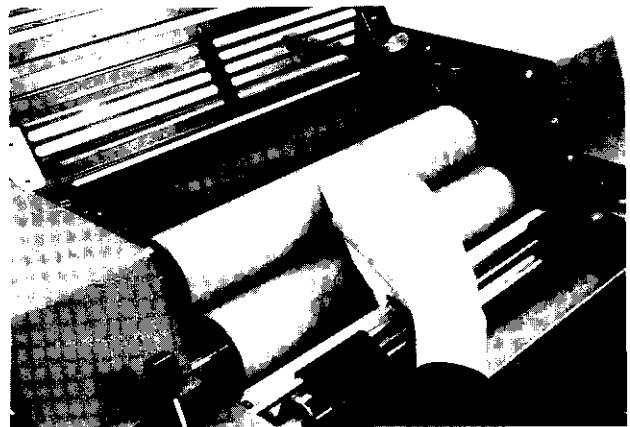

Note) After finishing the ink roller cleaning, be sure to remove the ink roller cleanup attachment. If the ink roller cleanup attachment blade edge contacts the dry ink oscillating roller while the machine is rotating, it will damage the ink oscillating roller and ink roller cleanup attachment blade and cause the machine trouble. Be sure to clean the edge of the blade well.

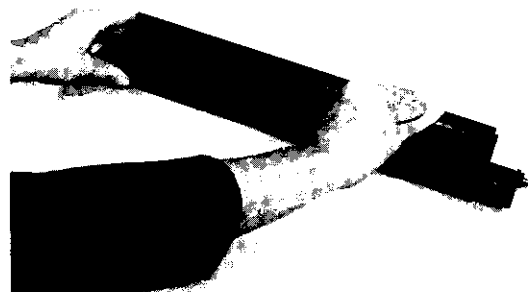

### B. Cleaning the Water Fountain

- 1) Drain the dampening solution in the water fountain.



- 2) Loosen the fixing screws (1) (On both the operation side and the non operation side) and remove the water fountain and clean it with water.

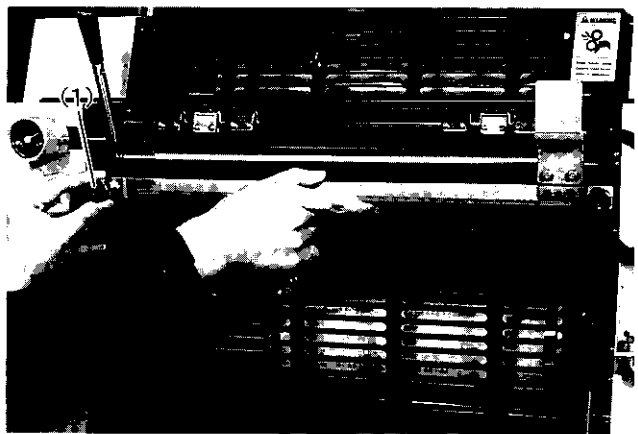

### C. Cleaning the Water Rollers

- 1) Set the water form roller release lever to the  position and remove the water form roller and the water ductor roller.

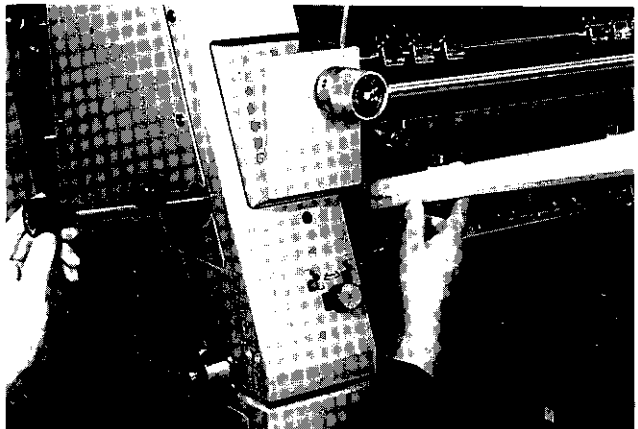

- 2) Use cleaning solution to remove any ink adhering on the molleton and then rinse it with water. After cleaning remove the water completely and rub the molleton by hand so that the grain will lie flat.



- 3) After cleaning the rollers, lubricate the bearing section (1) (ball bearings) on the water form roller and the ductor roller with a little oil and the molleton roller store it horizontally so it dries evenly.

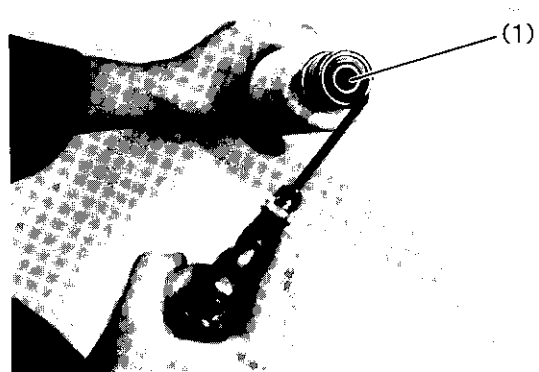

- 4) Clean the water fountain roller (1) and the water oscillating roller. If ink and foreign particles adhere on the surface of roller and in the water fountain, the dampening solution supply will be unstable. It stains on the roller cannot be removed, polish the surface with polishing powder and after that clean it with water. After cleaning, apply gum solution on the rollers.

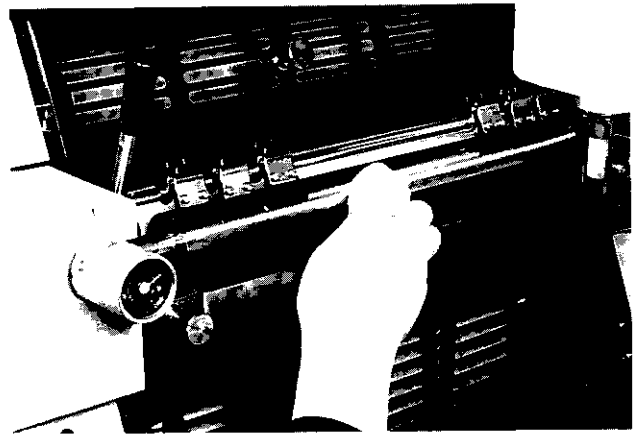

#### D. Cleaning the Cylinders

- 1) Remove the plate and clean the plate cylinder. As gum solution and ink are adhered on the cylinder wipe it off with the water and the cleaning solution after wiping off the ink.

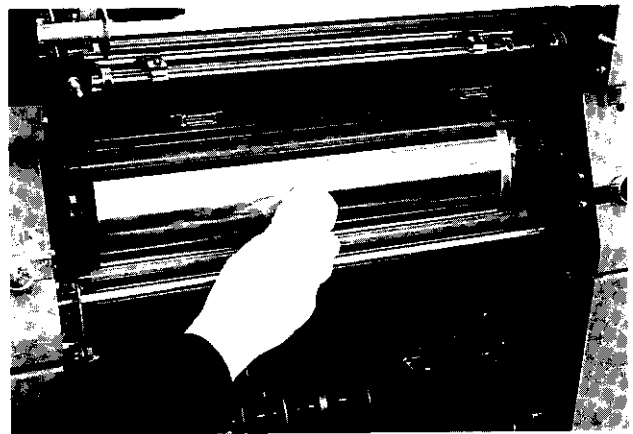

- 2) Clean the blanket, as ink, gum solution, and etching solution may be adhered on the blanket surface. After wiping off the ink, use a damp (With water) rag and wipe off the blanket.

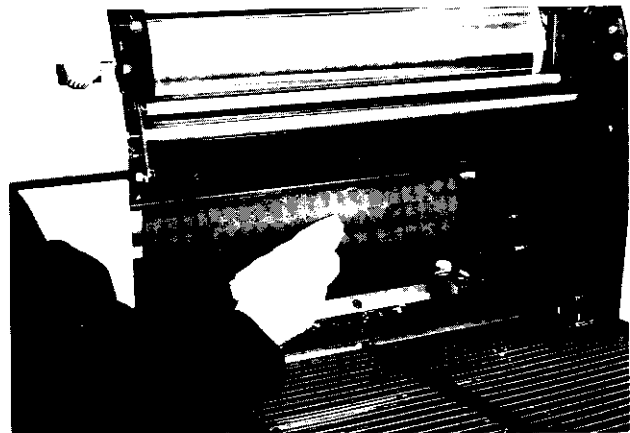

3) Cleaning the impression cylinder. Use a rag dampened with water and cleaning solution.

Note) For safety when cleaning the plate cylinder, the blanket cylinder, and the impression cylinder use the inching button to rotate the machine. First push the inching button and then after the rotation stops clean the cylinder.

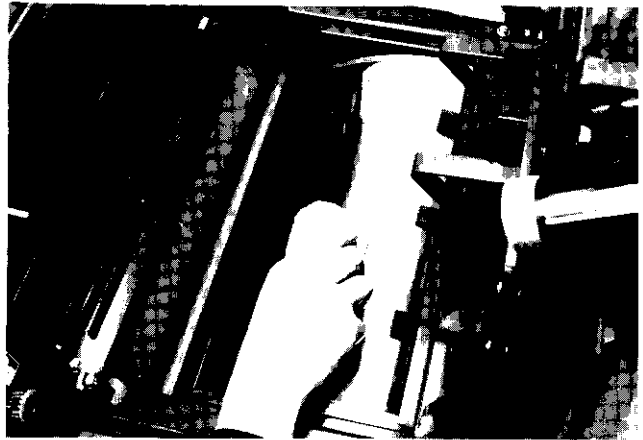

### E. Cleaning the Sensors

Foreign particles and spray powder that may adhere on the surface of the sensors, will cause the misoperation of the sensor. So, wipe off the sensor surface using a soft rag.

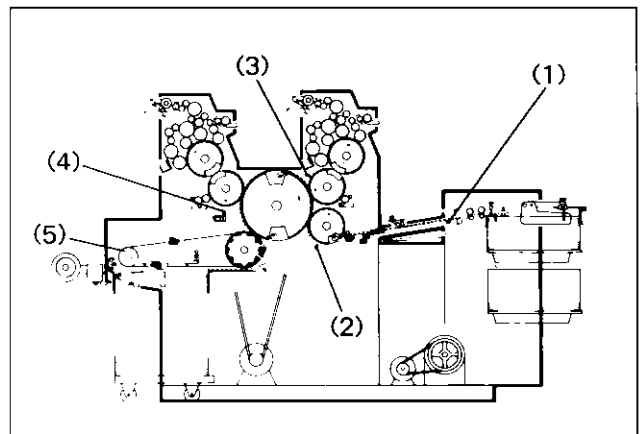

- 1) Photo sensor.....(1)  
(Counter and Paper Feed Delayed Timing Detector)
- Photo sensor .....(2)  
(Cylinder ON and Feed Jam Detector)

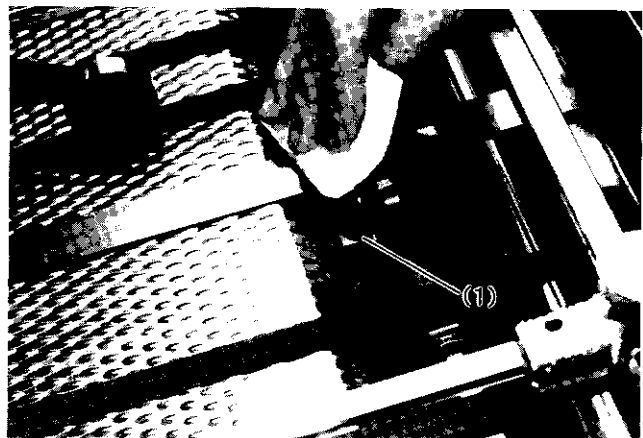

- 2) Photo sensor .....(3), (4)  
(Blanket Jam Detector)
- When cleaning the sensors (3) and (4), position the blanket cylinder notch at the position shown in the photo and clean the sensors.

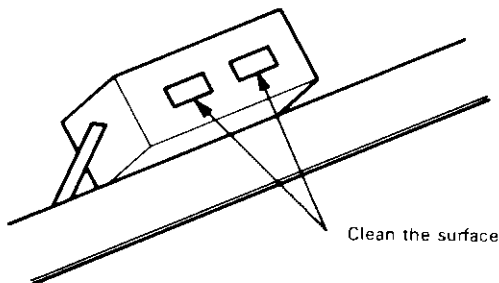

- 3) Delivery pile lowering sensor ..... (5)

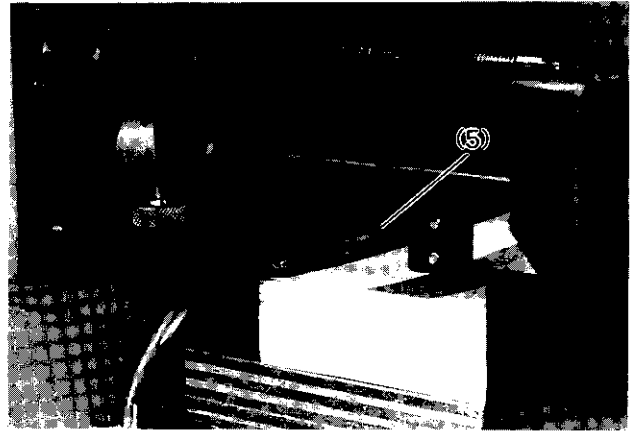

### F. Plate Preservation

To use a metal plate over again, correct plate preservation is necessary.

- 1) Using a sponge soaked with water, supply water onto the plate surface. Then using cleaning solution, wash off the ink on the plate surface and then wash the plate surface again with water.
- 2) Apply the metal plate protection ink on the plate after dampening the plate surface.
- 3) First rinse it with water, then dry it, then apply gum solution and finally dry it.

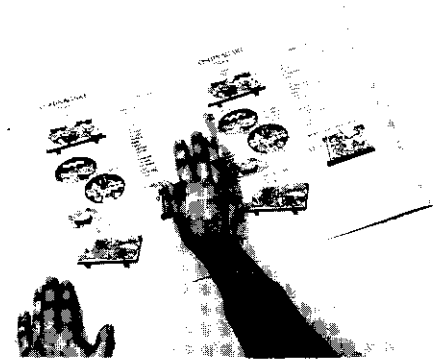

## 4-2 Roller Pressure

### A. Checking the Ink Form Roller Pressure

The form roller pressure has a great influence on the printing result. Check the pressure regularly.

Ink form roller nip width

Symbol	Standard nip width (mm)
A	3.0
B	3.0
C	3.0
D	3.5
E	3.5
F	3.5

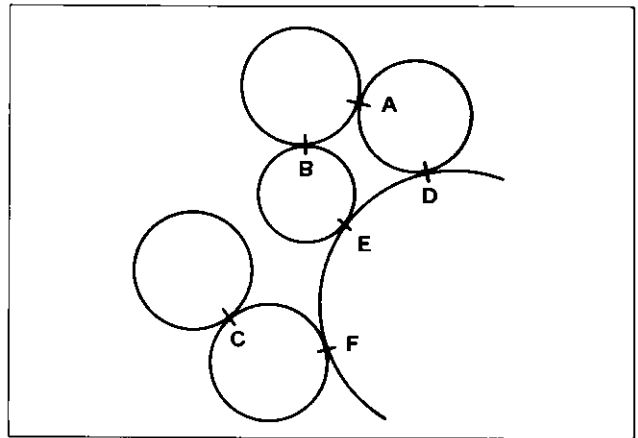

- 1) The pressure between the form roller and the oscillating roller.

<Checking Procedure>

Check with the operating lever at the  position.

1. Apply ink evenly on the roller.
2. After rotating the cylinders a few times and then stop the machine.
3. After stopping the machine wait 30 seconds and then turn the handwheel and check the nip width (A) formed on the rollers.

Note) When checking the pressure, set the water form roller release lever, at the  position.



<Adjustment Method>

Turn the adjustment screw to adjust it. There are three screws (1), (2), (3) located on both the operation side and the non operation side. When turning them in the counterclockwise direction, the pressure will be increased.

\* First Form Roller – Oscillating roller . . . (1)

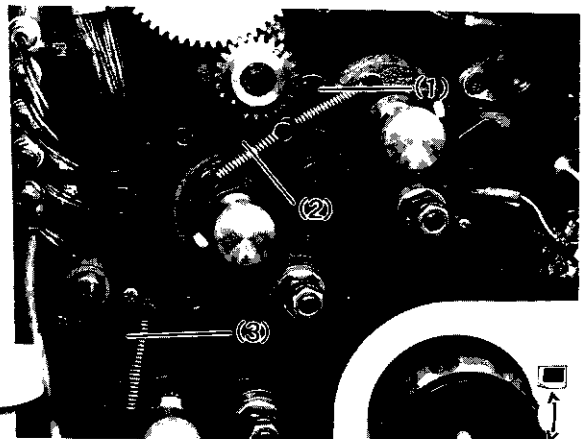

\* Second Form Roller– Oscillating roller. . . (2)

\* Third Form Roller – Oscillating roller. . . (3)



- 2) The pressure between the form roller and the plate

<Checking Procedure>

1. Apply ink evenly on the roller and rotate the machine a few times.
2. Set the operating lever at the  position and stop the machine.
3. After waiting 30 seconds, return the operating lever to the  position and check the nip width (A, B) on the plate surface.

Note) When checking the pressure, set the water form roller release lever at the  position.

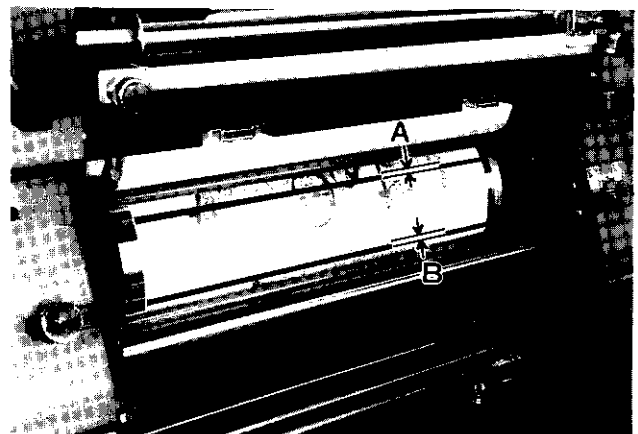

<Adjustment Method>

Loosen the lock nut (1), (2), (3) and turn the pressure adjustment nut to adjust it. There are three pressure adjustment nuts located on both the operation side and the non operation side. When turning them in the direction of the arrow that is marked on the nut the pressure will be increased.

- \* First Form Roller – Plate ..... (1)
- \* Second Form Roller – Plate ..... (2)
- \* Third Form Roller – Plate ..... (3)

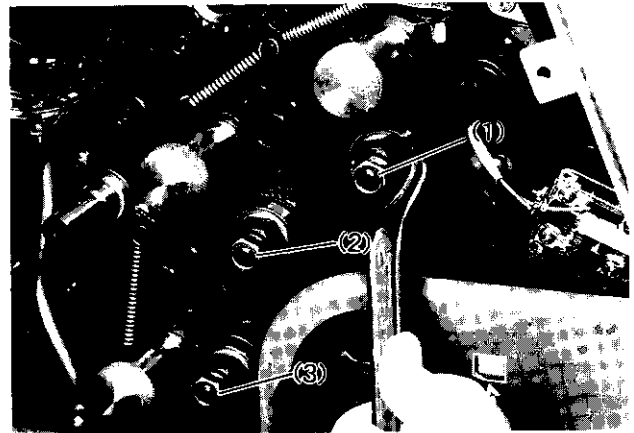

**B. Water Form Roller**

When checking the water roller pressure, do it after feeding the dampening solution until the molleton rollers are as damp as they would be during normal printing.

- 1) The water roller pressure is checked by the force required to pull out a strip of paper which is inserted between the rollers. The strip of paper used has to have a thickness of about 0.1 mm.

Symbol	A : B : C : D
Pressure	10 : 8 : 6 : 6

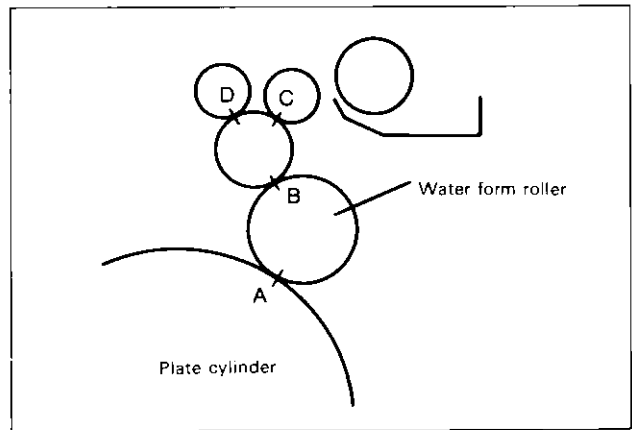

- 2) The water roller A pressure of 10 means a pressure where the strip of paper can just be pulled out without tearing the strip of paper. The B and C pressure should be set at 8 and 6 in comparison with the A pressure 10.

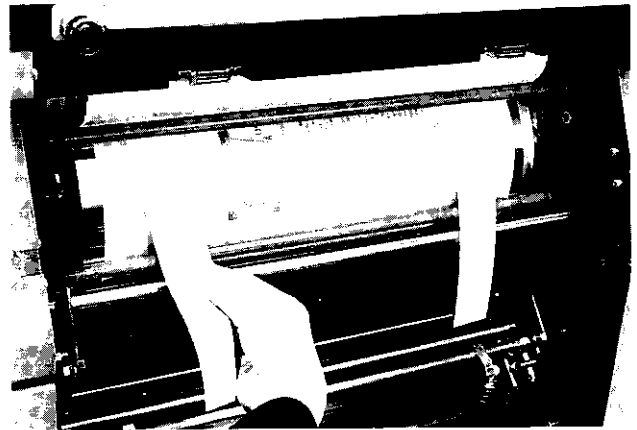

- 3) The pressure between the water form roller and the oscillating roller  
 Set the operating lever at the  position and check the pressure of water form roller and oscillating roller. When screwing in the adjustment screws (1) (On both the operation side and the non operation side) the pressure will be increased.

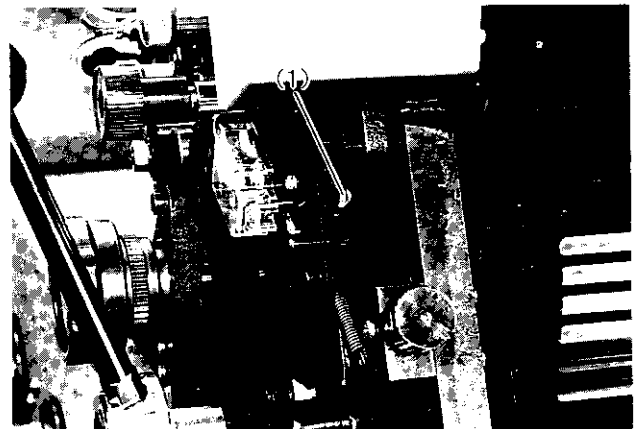

4) The pressure between the water form roller and the plate surface

Set the operating lever at the  position to contact the water form roller on the plate surface and then check the pressure. When turning the adjustment knobs (1) (On both the operation side and the non operation side) in the counterclockwise direction, the pressure will be increased. When using a paper master, cut off a strip (30mm wide) and use it to check the pressure.

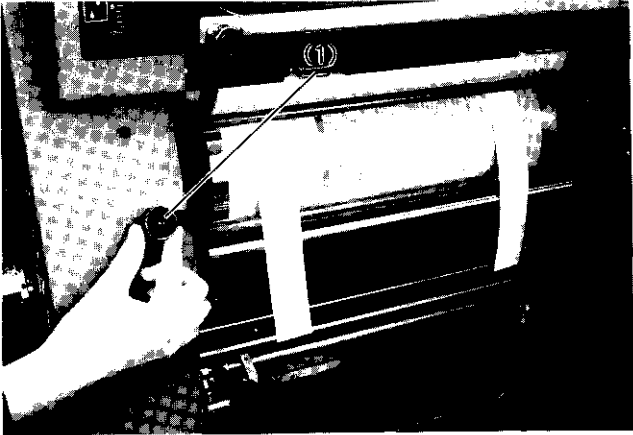

5) The pressure between the water ductor roller and the oscillating roller

Loosen the screw (1) and move the water ductor drive arm (2) to adjust the total pressure and the parallel pressure on both the operation side and the non operation side.

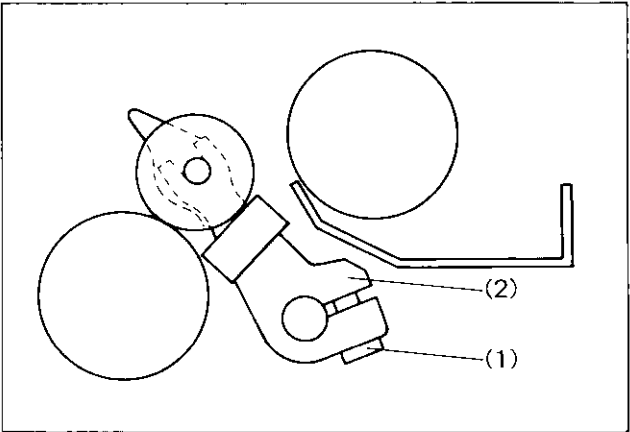

(Reference) Mounting and Removing the Roller  
When mounting each roller on the machine, follow the order of the numbers shown in the illustration.

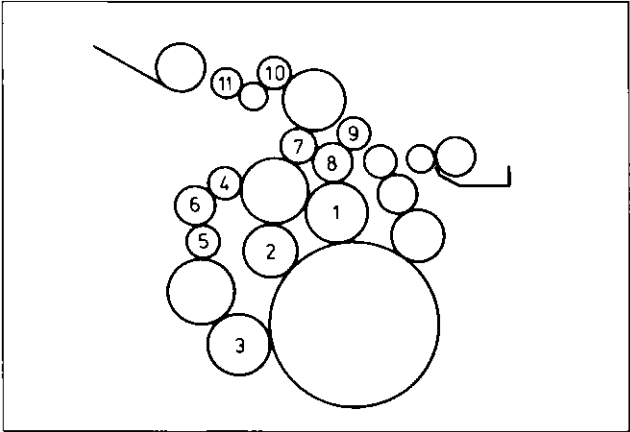

**C. Mounting the Roller**

When mounting each roller on the machine, please be aware of the points given below.

1) The first unit (A) rollers have tape wrapped around the bearing and the second unit (B) does not.

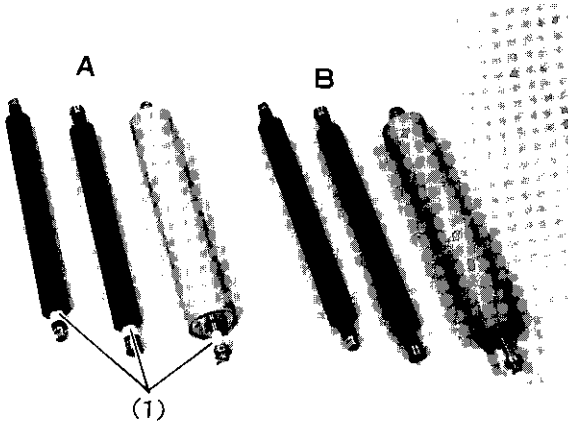



- 2) The first unit water rollers are marked with gray tape and the second unit rollers are marked with blue tape. Mount the rollers so that the side with the tape is mounted on the non operation side.

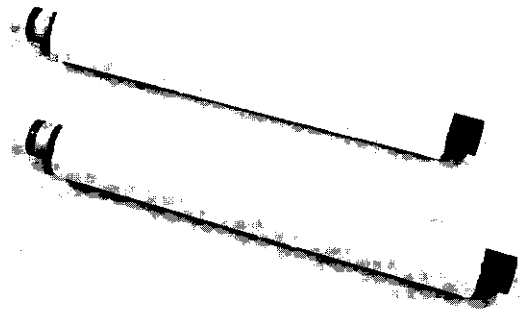

- 3) The Water ductor roller and the ink ductor roller should be mounted so that the side with the pin is on the operation side.  
Set the pin (1) in the hole on the bracket (2).

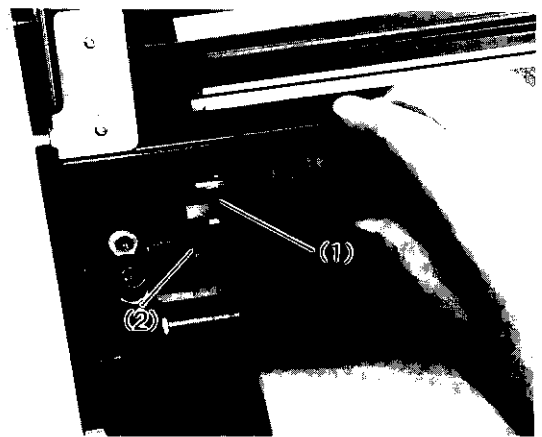
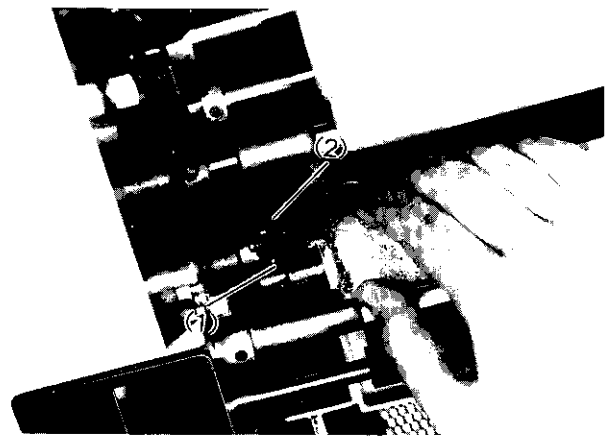

### 4-3 Regular Maintenance

#### A. Maintenance of the Pump

1) Lubrication of the pump

The air pump can be seen on the bed section at the paper feed side. Check the oil level once a month and be sure that the oil level in the oil cup (1) is never less than half full.

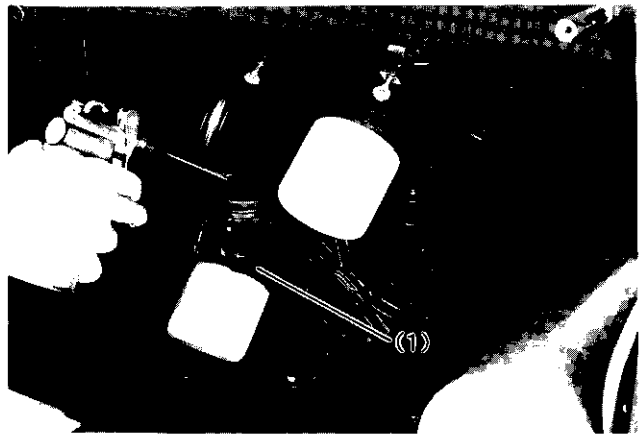
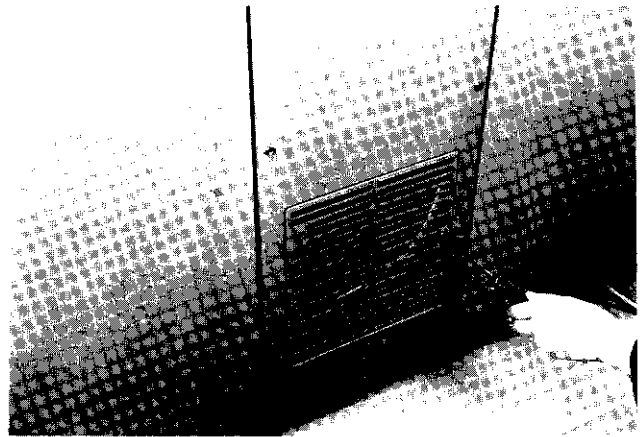

2) Cleaning the filter

If the pump filter (1) is dirty, the vacuum force of the pump will be lowered. If the warning lamp lights, remove the filter and remove any dirt and foreign particles on the filter using a brush and dip it in cleaning solution.



### B. Cleaning the Electrode

When the static eliminator is used for a long time, carbon will build up and adhere on the electrode. This causes the eliminating force to become weak. Clean the electrode with the brush periodically.

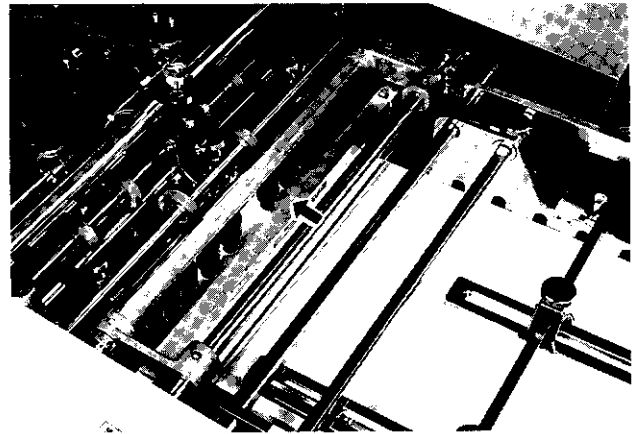

Feeder side

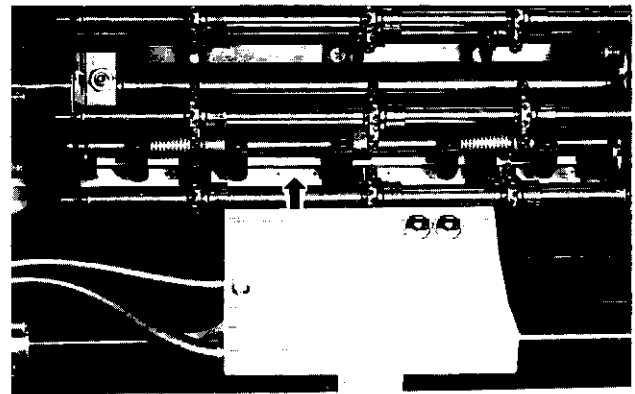

Delivery side

### C. Cleaning the Skid Roller

If the skid rollers are not smooth to rotate, dust or foreign particles may be adhered on the bearing. Clean the bearing using cleaning solution. After cleaning it, lubricate it with a little oil.

Note) If too much oil is used and is on the surface of the bearing wipe it off completely.

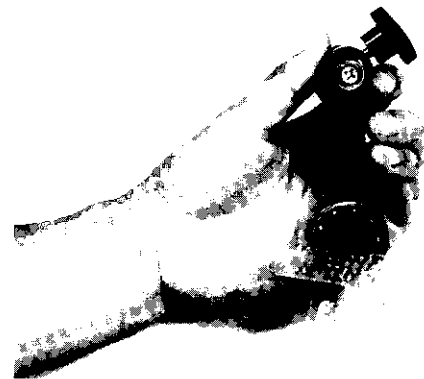

### D. Cleaning the Pullout Rollers and Guide Rollers

If ink adheres on the pullout rollers and the guide rollers, the roller surface will become hard. Once a week, clean it after checking the surface of the roller.



**E. Maintenance of the Powder Spray Device**

After using the spray unit, and then not using it for a long time, the spray powder will harden in the spray hose if it is not cleaned out. After using the powder spray unit, remove the spray powder bottle (1) and feed waste paper to use up any spray powder remaining in the hose.

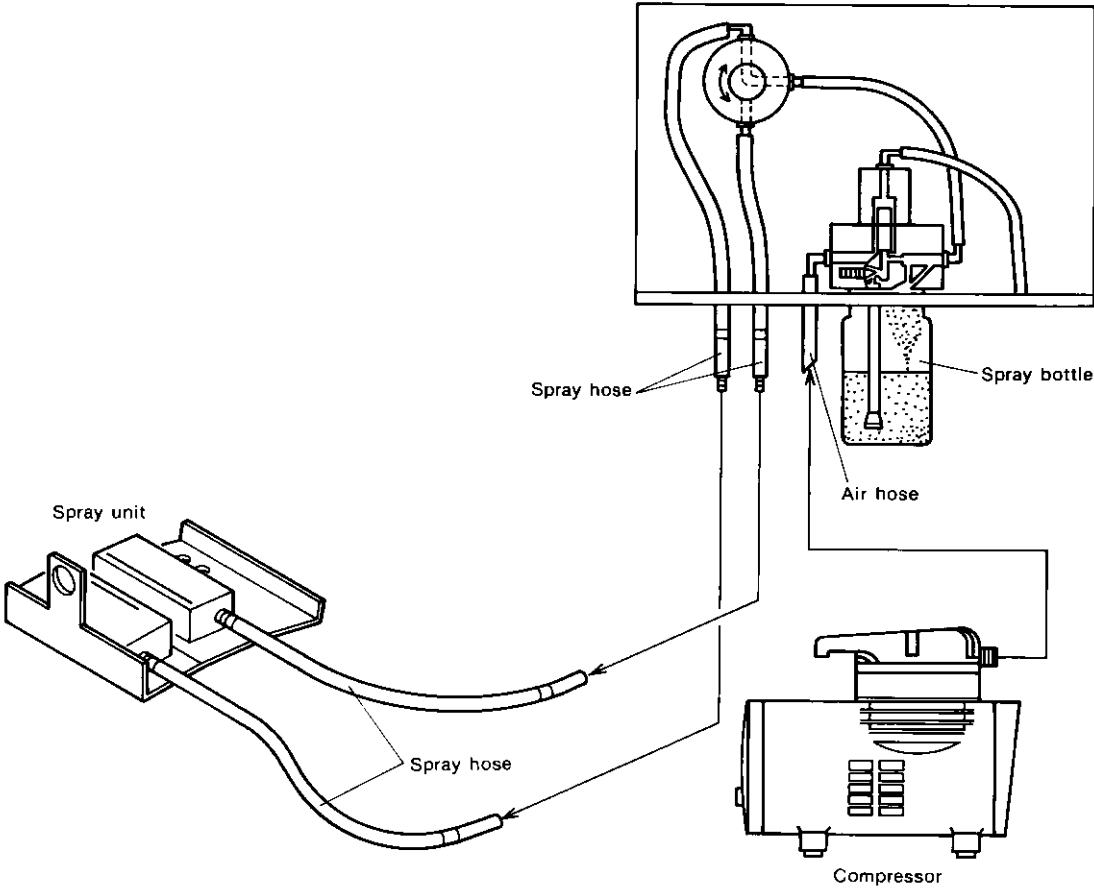

### 4-4 Lubrication

A. As an offset press is characterized by high precision and the high speed operation, special care must be taken to prevent the wearing of the parts and the prevention of seizing. The wearing of only one component may cause the lowering of the precision of the whole machine. Therefore, please be sure to supply oil and grease periodically to the specified places following the lubrication chart included with this machine.

1) Before starting the machine lubricate the machine using the centralized oiling system.

(Reference)

Pull the lever and release it after 2 to 3 seconds to supply the oil. Repeat this 2 to 3 times.

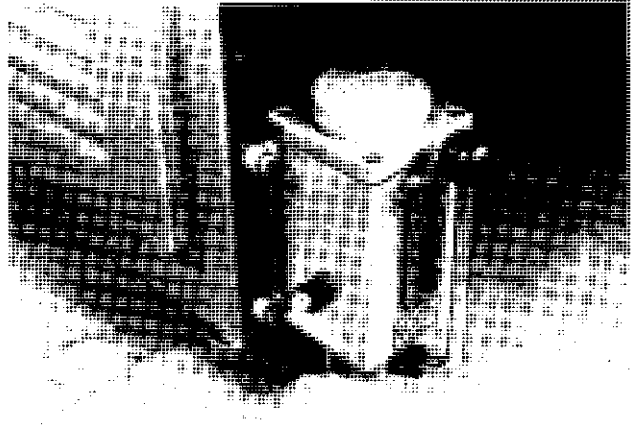

2) Before the oil level reaches the lower limit line supply more oil through the filter.

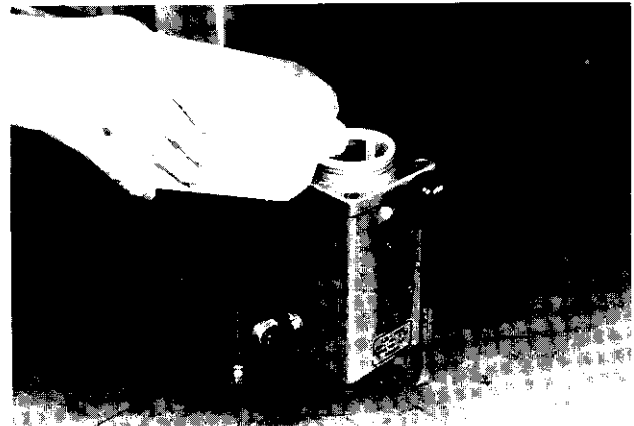

3) When it is time for the periodic lubrication of the machine, the lubrication warning lamp will light. When the lamp (1) lights, lubricate the required parts of the machine.

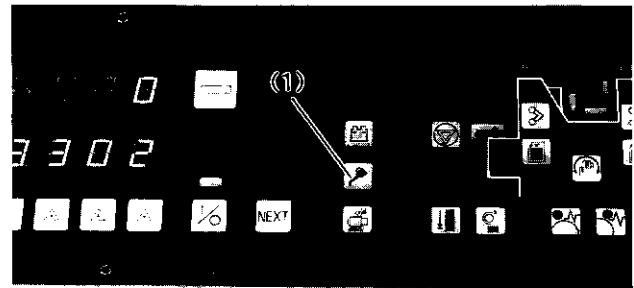

- 4) All of the required lubrication points, are marked with red paint. Use oil or grease depending on the function of the part.  
Lubricate the machine following the lubrication chart that is included with the machine.

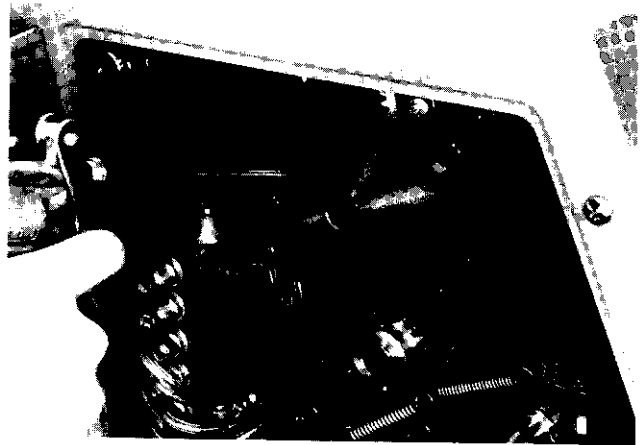

[Recommended Lubrication List]

Use \ Maker	Shell	Mobil	Esso
Oil for centralized lubrication	TELLUS OIL 32 or 46	Mobil DTE 24 or 25	FEBIS K32 or 46 EXXON D-3 10W or 15W
Vacuum pump oil	TELLUS OIL 32 or 46	Mobil DTE 24 or 25	FEBIS K32 or 46 EXXON D-3 10W or 15W
Gear oil Bushing oil	GC OIL SE 100	Mobil DTE Oil Heavy	SPARTAN EP 100
Grease	SHELL ALVANIA GREASE 1 SHELL ALVANIA EP GREASE 1 SHELL ALVANIA GREASE R1	Mobilux EPI	ESTAN 1 NEBULA EP1 BEACON EP1 LADEX 1

- ※ The recommended oil for Centralized lubrication and Vacuum pump is equivalent to the Anti wear type ISO (International Organization for Standardization) VG 32 or 46.
- ※ The recommended oil for Gear and Bushing is equivalent to the Anti wear type ISOVG 100.
- ※ The recommended grease is equivalent to the multipurpose grease (Li) NLGI No.1.
- ※ Supply oil and grease every week for 3 months after installation. After that, lubricate the machine following the lubrication chart.

## 4-5 Supplies

### A. Replacing the Blanket

After the blanket is used for a long time, the rubber will age causing the adhesiveness to be increased and the surface of the blanket to become slick and shiny. As a result, paper may adhere on the blanket surface, causing such picking trouble as peeling and roughness on the paper to occur. If this problem becomes worse, paper may be jammed on the blanket cylinder or ink may not be transferred smoothly onto the blanket resulting in poor printing. When this happens, replace the blanket with a new one.

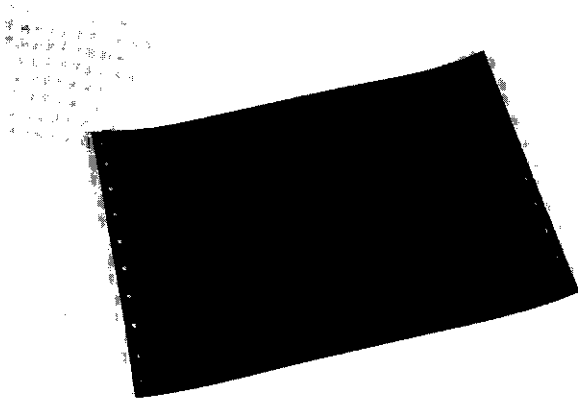

#### Slotted blanket

There are two types of slotted blankets. One is the single type blanket and the other is the double packing type blanket.

#### [Removing the blanket]

##### a. If a slotted blanket is used :

- 1) Loosen the tension knob.
- 2) Remove the blanket from the blanket cylinder by loosening the four bolts with the punch mark on the tail edge clamp.

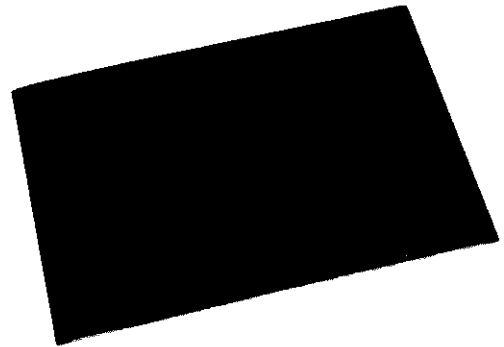

#### Quick set blanket



- 3) Remove the blanket by pushing the forward inching button.

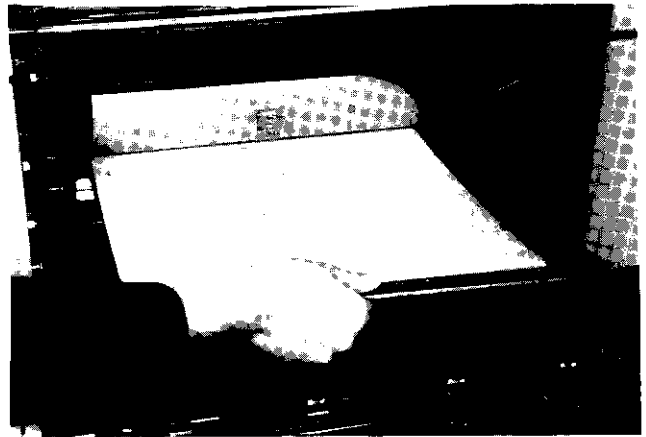

- 4) Remove the blanket from the blanket holders by loosening the four bolts with the punch mark on the leading edge clamp.



**b. If a quick set blanket is used :**

- 1) Loosen the tension knob.



- 2) Remove the blanket from the blanket cylinder.





- 3) Remove the blanket by pushing the reverse inching button.

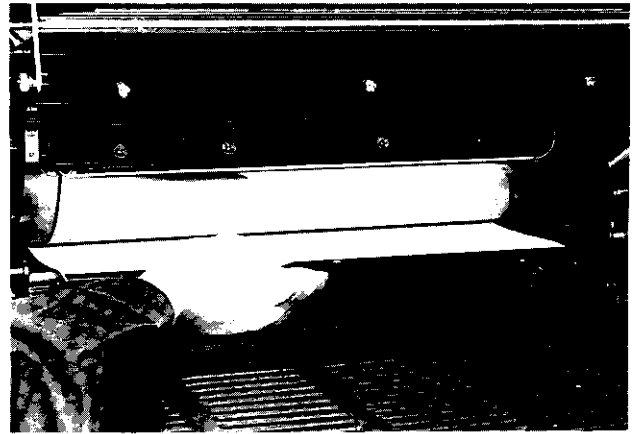

**[Mounting on the cylinder]**

**a. If a slotted blanket is used :**

- 1) Mount the blanket on the cylinder.  
Note) When mounting the double packing blanket, mount the leading edge holder on the cylinder first.



- 2) After mounting the blanket, turn the tension knob to tension the blanket. Then feed about ten sheets of paper to fit the blanket to the cylinder and then tension the blanket again. Repeat this procedure 2 to 3 times.



- 3) Finally turn the tensioning bolt (on both the leading and tail edges) about 1/2 to one turn for the final tensioning before printing.



**b. If a quick set blanket is used :**

1) Mount the blanket on the cylinder.

Note) When mounting the double packing blanket, mount the leading edge holder on the cylinder first.

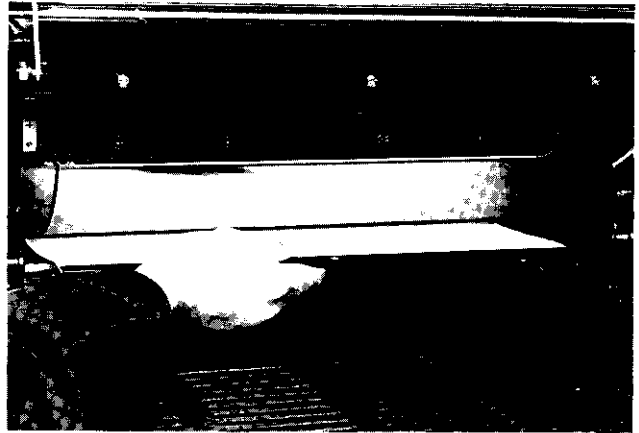

2) After mounting the blanket, turn the tension knob to tension the blanket. Then feed about ten sheets of paper to fit the blanket to the cylinder and then tension the blanket again. Repeat this procedure 2 to 3 times.



3) Finally turn the tensioning bolts (on both the leading and tail edges) about 1/2 to one turn for the final tensioning before printing.



**B. Replacing the Sheet Separators**

When the edge of the sheet separator is bent, replace it with a new one.

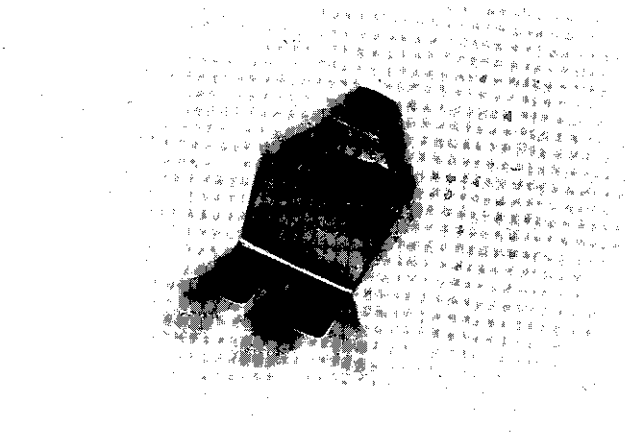

- 1) Loosen the screw (1) and remove the sheet separator.

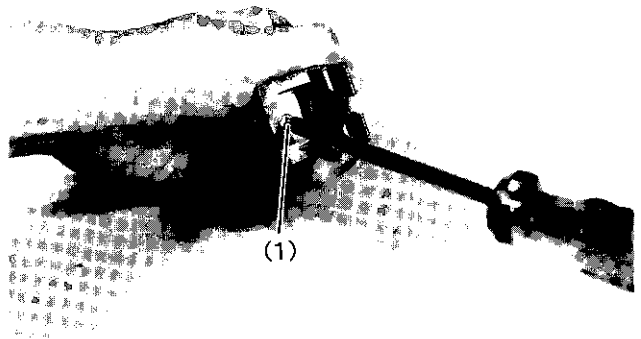

- 2) Mount the new separator and set the sheet separator so that it is positioned 5 mm out from the front surface of the sheet separator bracket and is 6 mm above the notch in the sheet separator bracket.

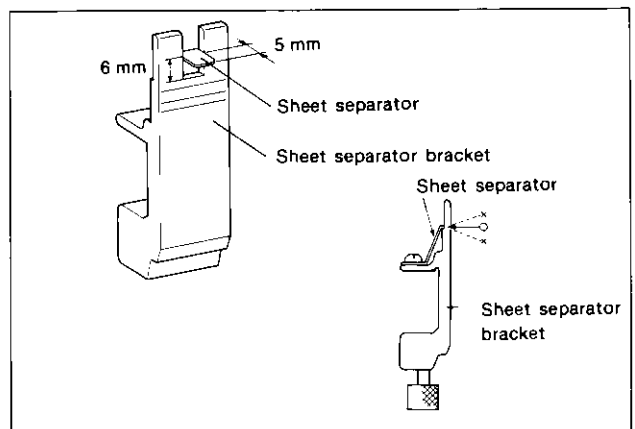

### C. Replacing the Molleton Cover

When replacing the molleton cover the important thing is not to mistake the molleton grain direction.

Rubbing the molleton by hand, in the "normal" direction and the grain will lie flat and in the "opposite" direction the grain will stand up. When mounting the molleton cover the correct direction is so that the grain lies flat.

If it is mounted backwards the molleton cover become loose and cannot be used.

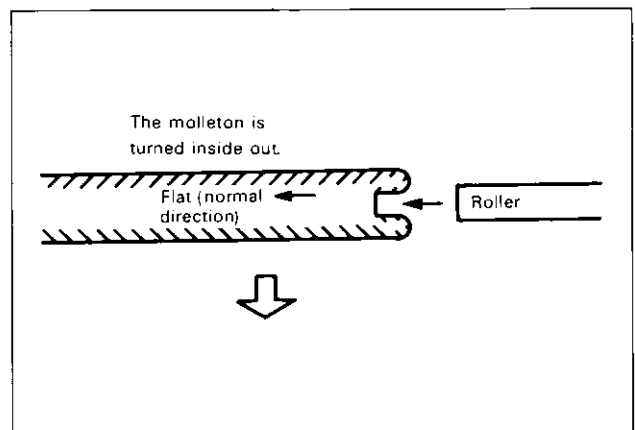

#### <Molleton Cover Mounting Procedures>

1. Turn the molleton inside out.
2. Stand the roller up and mount it in the "normal" direction and pull it down slowly.
3. After sewing up one side, rub it in the opposite direction fully so that the cover fits snugly on the roller and then cut off the excess molleton and sew that side up.



# Troubles and Countermeasures

During the printing if trouble like these listed below occurs first follow the instructions given below and if the trouble is not corrected then contact your service technician for after sales service.

## 5-1 Troubles and Countermeasures

### A. Insufficient Plate and Impression Pressure

Cause

The plate pressure and the impression pressure are unstable.



Countermeasure

1. Check the plate pressure and the impression pressure.
2. Replace the blanket (If the blanket is partially damaged.)
3. Check the plate and the blanket packing thickness.

(Reference) The plate pressure and the impression pressure checking method

#### 1) Checking the plate pressure

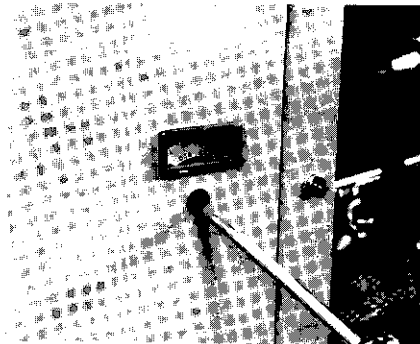

1. Set the plate pressure adjustment screw to the thickness of the plate.

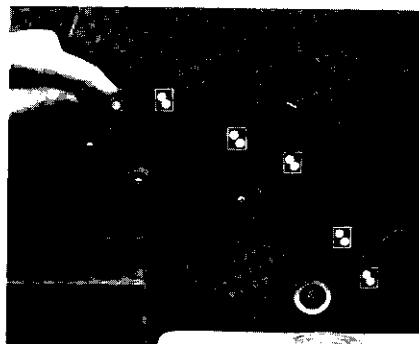

2. Set the water form roller release lever at the position.

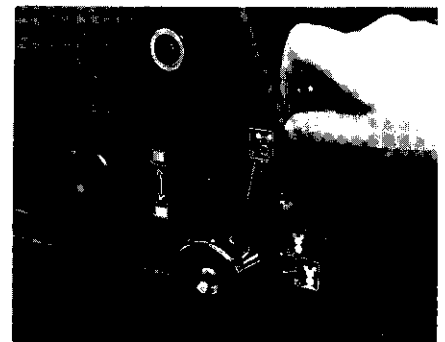

3. Set the operating lever at the position and after feeding ink onto the plate surface, return the lever to the position .

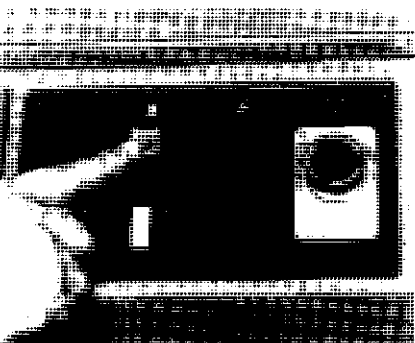

4. Set the printing button ON, on the unit used.

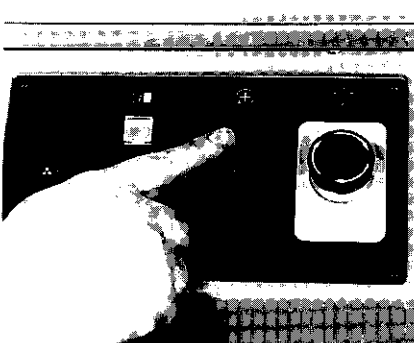

5. Feed a sheet of paper by inching operation.

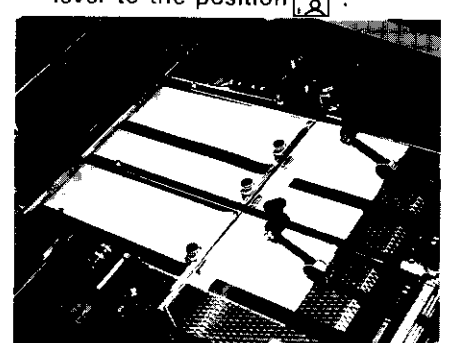

6. Feed the sheet up to the stop finger and stop the machine.



7. Transfer the nip width that appears on the plate surface onto a piece of paper and measure the nip width.

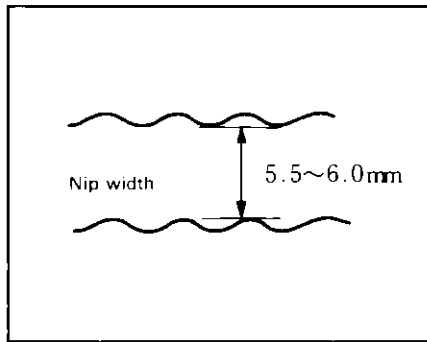

8. If the nip width is from 5.5 to 6.0mm, the plate pressure is correct.

Note) When measuring the nip width on the plate surface, measure the nip width that appears about 100mm from the leading edge of the plate.

2) Checking the impression pressure



1. Set the impression pressure adjustment dial to the thickness of the paper.

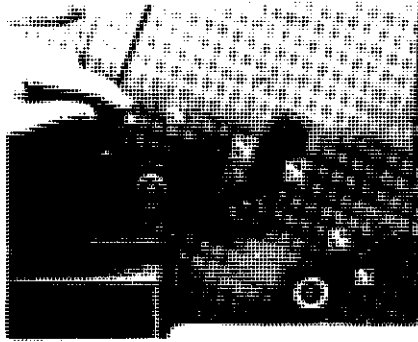

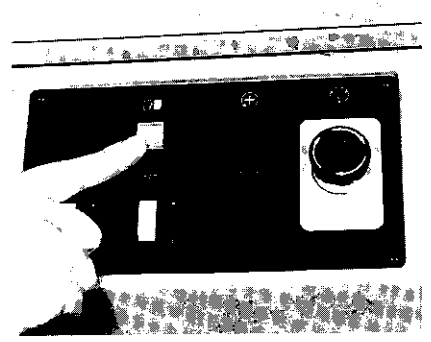

2. Set the water form roller release lever to the  position.

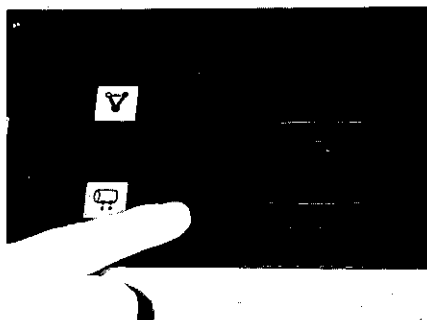

3. Set the printing button ON, on the unit used.



4. Pushing the crawl speed button  and then the drive button , start the machine on low speed.

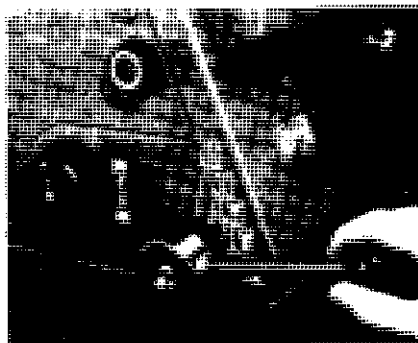

5. Set the operating lever to the  position and start the printing.

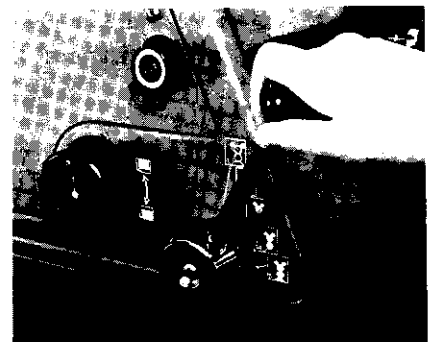

6. Shift the operating lever to the  position to stop the printing. After one sheet of paper reaches the impression cylinder.

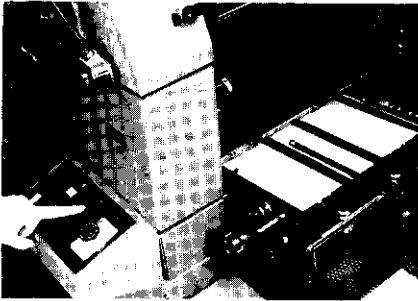

7. Feed the sheet of paper by inching operation.

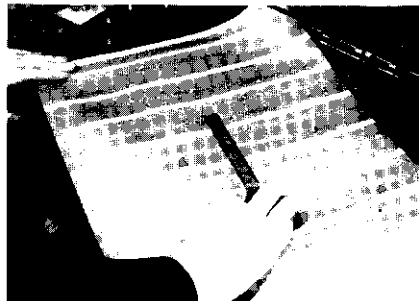

8. Measure the nip width that appears on the sheet.

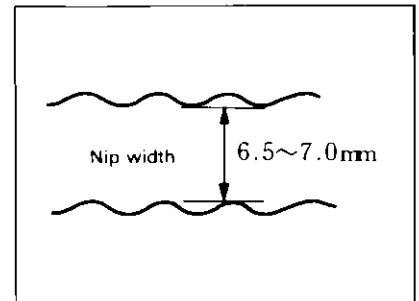

9. If the nip width is from 6.5 to 7.0mm, the impression pressure is correct.

### B. Doubling of the Image on the Printed Sheet

Cause	Countermeasure
Not enough blanket tension.	Correctly tension the blanket.
The blanket is smashed. (One part is concave.)	Replace it with a new one.
The impression pressure and the plate pressure are too strong.	1. Check the plate pressure adjustment dial setting and the impression pressure adjustment dial setting. 2. Check the plate and the blanket packing thickness.
The paper has waves.	Season the paper.
The paper is not transferred from the blanket smoothly because the ink tack is too high and the tail edge of the sheet moves too much.	Add extender into the ink to lower the tack.

### C. The second color is printed poorly (Poor trapping).

Cause	Countermeasure
The second color ink tack is too high.	Add extender in the ink to lower the tack.

**D. The paper is not fed smoothly .**

Cause	Countermeasure
A lack of pump or blower volume.	Clean the pump filter. (p. 103)
Poor rotation of the skid roller.	Clean the skid roller. (p. 104)
Poor rotation of the double sheet detector roller.	Clean the detector roller.
Static is generated on the paper.	1. Clean the electrode. (p. 104) 2. Adjust the humidity in the working area. (The proper humidity is around 60%.)

**E. Poor Registration**

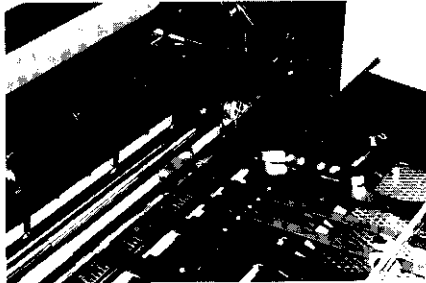
Cause	Countermeasure
< Front Registration >	
Poor positioning of the skid rollers.	Reposition the skid roller. (p. 69, 88)
The paper feed volume is improper.	Adjust the upper feed roller rotation volume (1-1/4 to 1-1/2 rotations). 
< Lateral Registration >	
The push side lay and the flat spring push too much.	Reset the push side lay and the flat spring.
The paper feed position is incorrect so the edge of the paper is hooked on the stop finger.	Change the paper feed position.

**F. The spray power is not sprayed.**

Cause

The spray fuse has blown.



Countermeasure

Replace the fuse of the spray device.



The spray powder hose and the air hose is plugged.



Clean the inside of the spray powder hose and the air hose.

**G. Ink is not supplied on the rollers (Roller stripping).**

Cause

Oil or foreign particles are adhered on the surface of the rollers.



Countermeasure

Clean each roller using cleaning solution. If the foreign particles are still not removed, polish each roller with polishing powder.

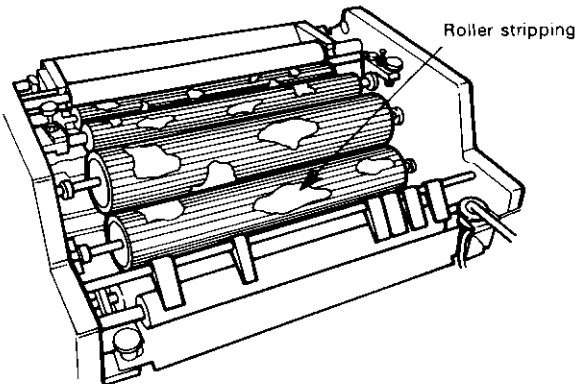

**H. The paper is bent.**

Cause

The sheet separators are not properly set.



Countermeasure

Reset the sheet separator. (p. 58, 109)

The paper is not fed smoothly to the retainer from the pullout rollers.



Reset the retainers. (p. 68, 88)

**I. The paper is wrinkled.**

Cause

The paper has waves.



Countermeasure

Season the paper.

The impression pressure is too strong.



1. Check the impression pressure dial setting.
2. Check the blanket packing thickness.



## J. Error Message

When electrical problem occur, an error message will be indicated. If the error message (E-1, E-2, E-3, E-4, E-5) appear on the set counter, please call your service technician and explain the error message that appeared.

When the message "E-5" appears, the machine can not be run.

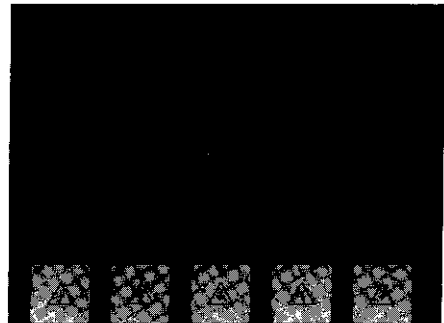

## **RYOBI LIMITED**

**TOKYO HEAD OFFICE;**  
3-15-1 SOTOKANDA, CHIYODA-KU  
TOKYO, 101, JAPAN  
TEL. (03) 3257-1502  
FAX. (03) 3257-0223  
TELEX J33672 RYOBI