

Stapler / Folder Model 61

Operator Manual

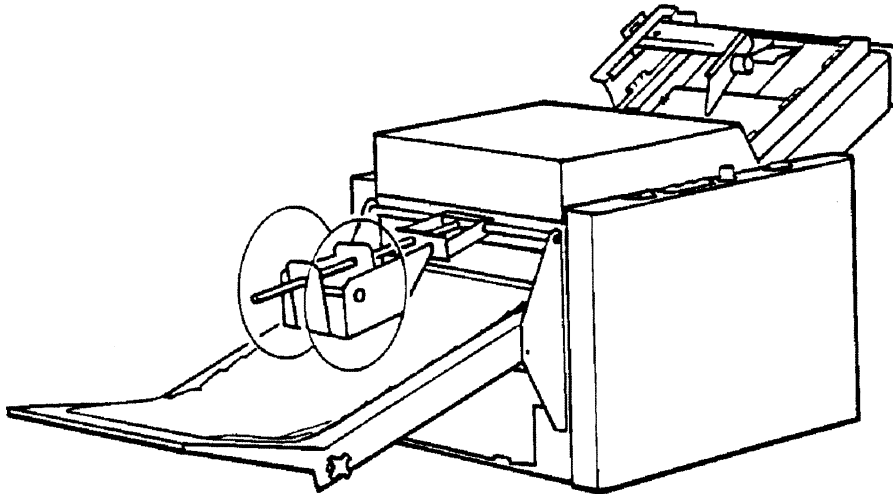

March 1994

Part No. 61086

The Belt Stacker shown
is optional

Table of contents

1. Introduction

1-1	Introduction	1-1
-----	--------------	-----

2. Installation

2-1	Installation	2-1
-----	--------------	-----

3. Getting to know the Stapler / Folder

3.1	Main components	3-1
3.2	Infeed section, upper	3-2
3.3	Infeed section, collator side	3-3
3.4	Control panel	3-4

4 Operator instructions

4.1	Set up of stapler / folder (stapling-folding)	4-1
4.2	Set up of stapler / folder (folding only)	4-1
4.3	Set up of stapler / folder (stapling-folding / off-line)	4-2
4.4	Set up of stapler / folder (folding / off-line)	4-2
4.5	Set up of stapler / folder (block stapling / off-line option 1)*	4-3
4.6	Set up of stapler / folder (block stapling / off-line option 2)*	4-4
4.7	Operating the stapler / folder on-line	4-5
4.8	Operating the stapler / folder off-line	4-5
4.9	Set up for odd paper size	4-6
4.10	Reset to standard paper size	4-6

* Only OFF-line

5. Maintenance

5.1	Cleaning fold rollers	5-1
5.2	Cleaning of rear jogger rollers	5-2

6. Problem solving

6.1	Trouble shooting table	6-2
-----	------------------------	-----

7. Specifications

7.1	Specification table	7-1
-----	---------------------	-----

1.1 Operational safety

Attention to the following notes ensures the continued safe operation of your equipment.

Always connect the equipment to a properly grounded power source receptacle. In doubt, have the receptacle checked by a qualified electrician.

WARNING: Improper connection of the equipment grounding conductor can result in electrical shock.

Always follow all warnings marked on, or supplied with, the equipment.

Always locate the equipment on a solid support surface with adequate strength for the weight of the machine.

Always exercise care in moving or relocating the equipment.

Always keep magnets and all devices with strong magnetic field away from the machine.

Never use a ground adapter plug to connect the equipment to a power source receptacle that lacks a ground connection terminal.

Never attempt any maintenance function that is not specifically described in this documentation.

Never remove the covers or guards that are fastened with screws.

Never install the unit near a radiator or any other heat source.

Never override or "cheat" electrical or mechanical interlock devices.

Never operate the equipment if you notice unusual noises or odours. Disconnect the power cord from the power source receptacle and call your customer service engineer to correct the problem.

2. Installation

2.1 Installation

1. Attach the power cord to the Stapler / Folder.
2. Attach the connection cable between the Stapler / Folder and the Collator.
3. Roll the Stapler / Folder up against the Collator make sure that the Collator studs enter the attachment bracket on the Stapler / Folder for the correct paper size.

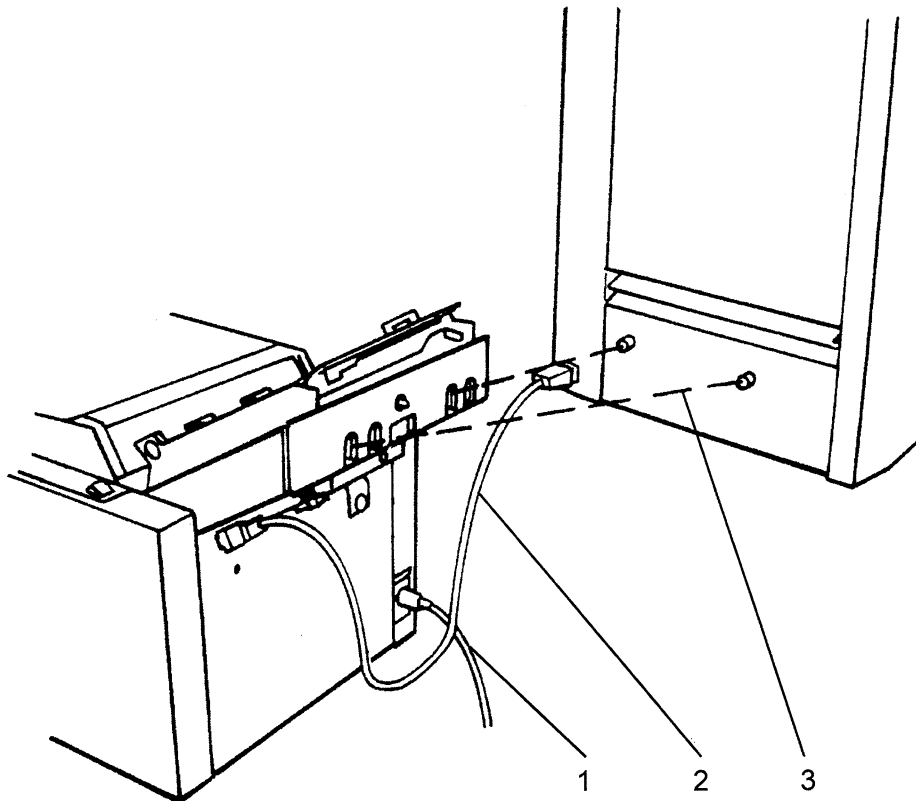

3. Getting to know the Corner Stapler

Take a few minutes to become familiar with the main components of the Stapler / Folder.

3.1 Main components

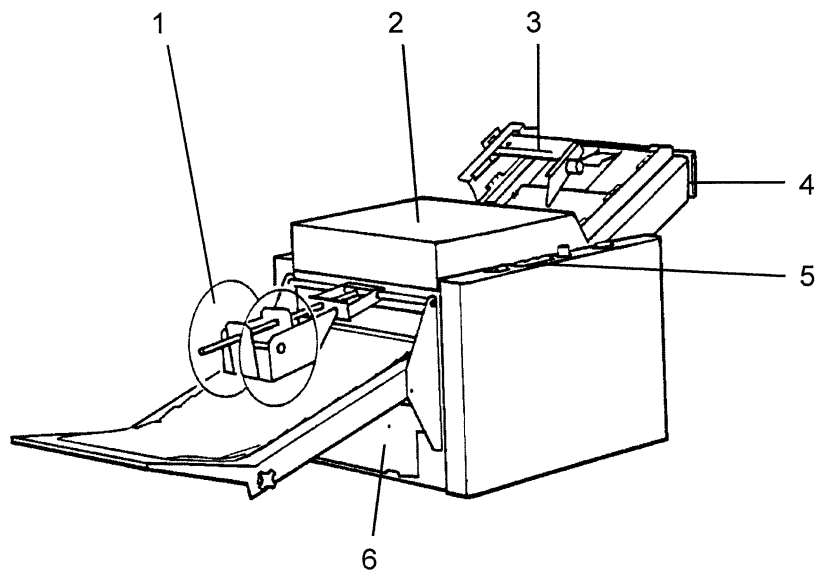

1. Stacker wheels
2. Top cover
3. Upper pressure roller assembly (Only used for ON-line operation to Collator)
4. Press area, machine release (Press here and the Stapler / Folder will be released from the Collator and can be rolled away)
5. Control panel
6. Fold stop assembly
7. Belt stacker (Optional accessory)

3.2 Infeed section, upper

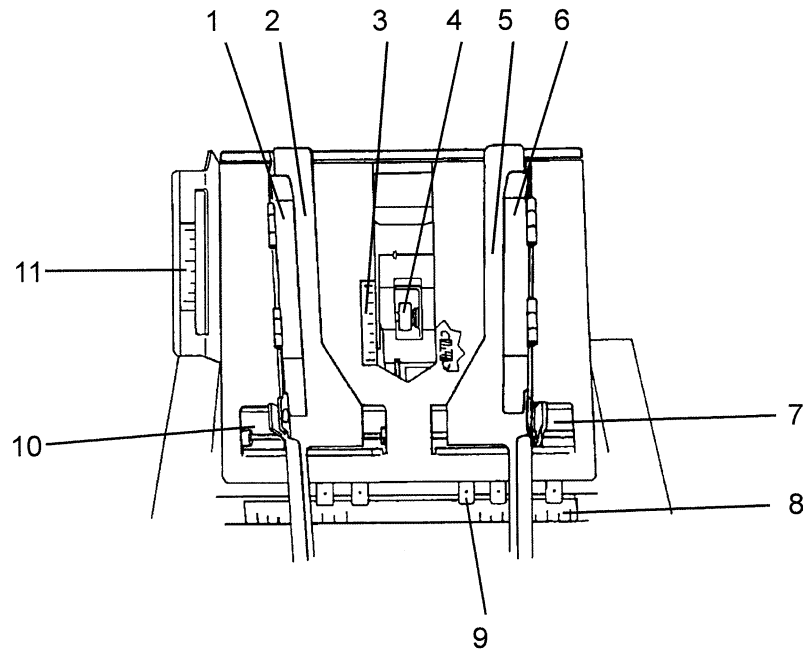

1. Upper guide, side jogger
2. Side jogger, rear
3. Scale, paper length
4. Rear jogger roller
5. Side jogger, front
6. Upper guide, side jogger
7. Release handle, side jogger
8. Scale, paper width
9. Anvil
10. Release handle, side jogger
11. Scale upper pressure roller assembly

3.3 Infeed section, Collator side

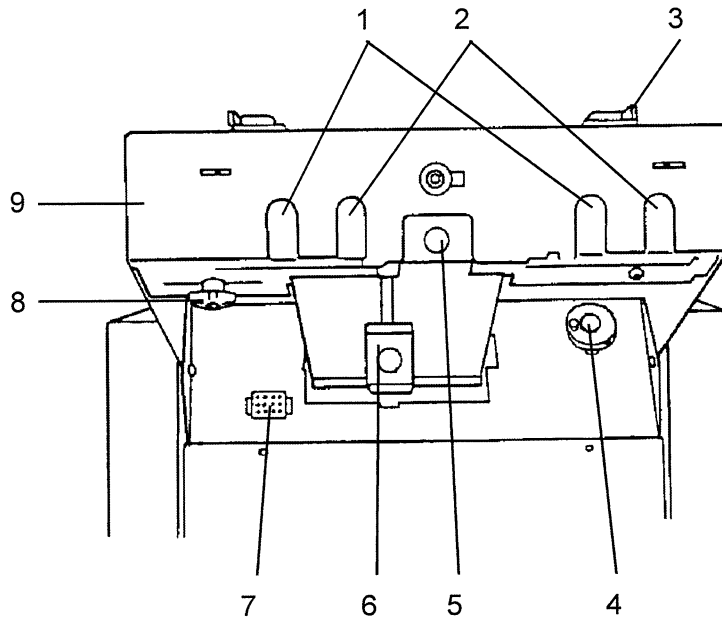

1. Positioning holes, small paper width (used for A4/8¹/₂" paper widths or sizes nearby)
2. Positioning holes, large paper width (used for A3/11" paper widths or sizes nearby)
3. Positioning mark (green) (Shall correspond to the green mark on the Collator)
4. Paper stop crank (used for adjustment to correct paper length)
5. Rear jogger latch (used to lower the rear jogger and enable Off-line operation)
6. Rear jogger adjustment latch (used to position the rear jogger to the paper length)
7. Receptacle, connection cable (The connection cable from the Collator connects here)
8. Knob, adjustment for odd paper size (by loosening the knob the attachment bracket can be individually positioned for odd paper sizes)
9. Attachment bracket

3.4 The control panel

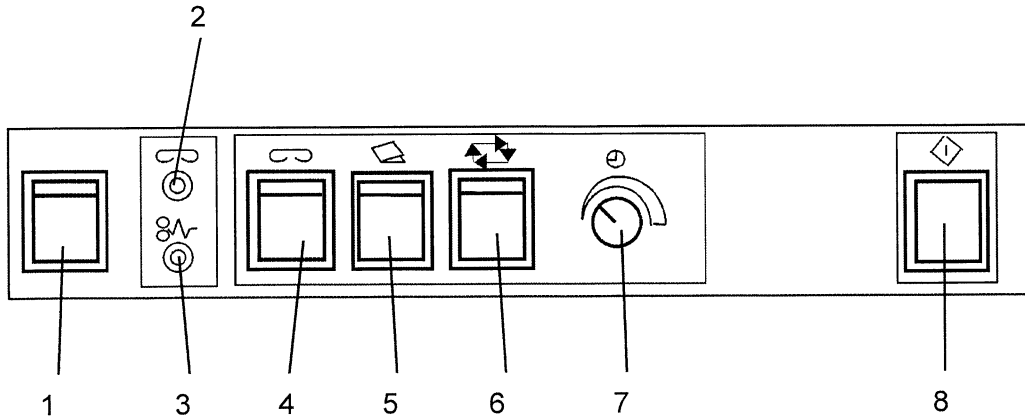

1. Power switch
2. Low staples indicator
3. Jam indicator *
4. Stapling ON / OFF
5. Folding ON / OFF
6. Automatic start ON / OFF (can only be used OFF-line)
7. Time delay (can only be used OFF-line)
8. Manual start button (can only be used OFF-line)

*** Not included in the conversion kit.**

4. Operator instruction

4.1 Set up of Stapler–Folder (stapling–folding)

1. Open the top cover.
2. Set the two side joggers to the correct paper size according to the scale.
3. Insert a set to the stapling area.
4. Move the rear side jogger up against the paper to verify that the side jogger aligns the sheets.
5. Turn the paper stop crank until the trail edge of the set is in line with the scale for paper length.
6. Move the rear jogger up against the trail edge of the set.
7. Remove the set.
8. Position the upper pressure roller to the scale.
9. Position the stapler heads over the anvils to be used.
10. Attach the stapler folder to the Collator and make sure that the green mark on the attachment bracket aligns with the green mark on the Collator.
11. Set the stapling switch to **ON** position.
12. Set the folding switch to **ON** position.
13. Close the top cover.
14. Set the power switch to **ON** position.

4.2 Set up of Stapler–Folder (folding only)

1. Same procedure as above with the exception that on item # 11 the switch is set to **OFF** position and item #9 is not performed.

4.3 Set up of Stapler–Folder (stapling–folding/OFF-line)

1. Remove the upper pressure roller assembly.
2. Flip over the side jogger upper guides (both side joggers)
3. Lower the rear jogger unit by pressing the rear jogger unit forward (green marked).
4. Open the top cover.
5. Set the side jogger to the correct paper size according to the scale.
6. Insert a set into the stapling area.
7. Move the rear jogger up against the paper to verify that the side jogger aligns the sheets.
8. Turn the paper stop crank until the trail edge of the set is in line with the scale for paper length.
9. Remove the set.
10. Position the stapler heads over the correct anvils.
11. Set the stapling switch to **ON** position.
12. Set the folding switch to **ON** position.
13. Close the top cover.
14. Set the power switch to **ON** position.

4.4 Set up of Stapler–Folder (folding/OFF-line)

1. Same procedure as above with the exception that on item # 11 the switch is set to **OFF** position and item #10 is not performed.

4.5 Set up of Stapler–Folder (Block stapling/OFF-line option 1)

1. Lower the rear jogger by pressing the rear jogger unit forward (green marked).
2. Remove the upper pressure roller assembly.
3. Flip over the side jogger upper guides (both side joggers)
4. Open the top cover.
5. Set the side jogger to the correct paper size according to the scale.
6. Insert a set into the stapling area.
7. Move the rear jogger up against the paper to verify that the side jogger aligns the sheets.
8. Turn the paper stop crank to position the set to the stapler.
9. Remove the set.
10. Position the stapler heads over the correct anvils.
11. Close the top cover.
12. Set the stapling switch to **ON** position.
13. Set the folding switch to **OFF** position.
14. Select manual or automatic start.
15. Flip down the fold stop to enable the sets to pass through the machine.
16. Set the power switch to **ON** position.

Note: *By using the adapter (optional) either the belt stacker or the delivery tray can be used for stacking of stapled sets*

4.6 Set up of Stapler–Folder (Block stapling/OFF-line option 2)

1. Lower the rear jogger by pressing the rear jogger unit forward (green marked).
2. Remove the upper pressure roller.
3. Flip over the side jogger upper guides (both side jogggers)
4. Open the top cover.
5. Set the side jogger to the correct paper size according to the scale.
6. Insert the two red pins in the holes in the side jogggers. (The pins are stored inside the machine over the fold rolls). These will stop the set in the correct position (in this mode the set will not be transported through the machine).
7. Insert set into the stapling area.
8. Move the rear side jogger up against the paper to verify that the side jogger aligns the sheets.
9. Remove the set.
10. Position the stapler heads over the correct anvils.
11. Set the stapling switch to **ON** position.
12. Set the folding switch to **OFF** position.
13. Select manual start.
14. Close the top cover.
15. Set the power switch to **ON** position.

4.7 Operating the Stapler–Folder (ON-line)

1. Verify that the set up of the Stapler–Folder is completed.
2. Select “third party output” on the Collator.
3. Press “callibration” on the Collator.
The set will enter the Stapler–Folder and remain in the stapling section unstapled.
4. Verify that the set is completed/correct press the Collator start button.

4.8 Operating the Stapler–Folder (OFF-line)

1. Select manual or automatic start.
 - 1.1 manual start:
Make sure that the time delay is set to minimum.
Press the start button for each operation.
 - 1.2 automatic start:
The set will automatically be stapled as it is inserted in the Stapler–Folder.
2. When operating, insert one set at a time. Align the set with your finger tip. When automatic mode is selected, set time delay to allow careful alignment.

NOTE: *The manual start button will light up when the next set may be inserted*

4.9 Set up for odd paper sizes

This procedure is to enable ON-line operation with paper sizes that deviate from the standard A4 / A3 for 50 HZ machines and 8¹/₂ / 11" width for 60 HZ machines.

1. Perform the setup of the Stapler-Folder for the paper size.
2. Attach the Stapler-Folder to the Collator, using the positioning holes on the Stapler-Folder that best matches the paper size. (Green mark on rear side jogger as close as possible to the attachment bracket.
3. Loosen the knob for adjustment to odd paper sizes on the attachment bracket.
Move the Stapler-Folder sidewise until the green mark on the rear side jogger corresponds the green mark on the Collator.
4. Tighten the knob.

4.10 Reset to standard paper sizes

1. Disconnect the Stapler-Folder from the Collator by pressing the attachment bracket (green marked side).
2. Loosen the knob for adjustment to odd paper sizes.
3. Slide the attachment bracket back to align it with the chassis in the Stapler-Folder, it will lock into place.

5. Maintenance

5.1 Cleaning of fold rollers

1. Clean these regularly with an alcoholic based cleaning liquid.

5.2 Cleaning of jogger rollers

1. Clean these regularly with an alcoholic based cleaning liquid.

6. Problem solving

6.1 Problem solving

PROBLEM	POSSIBLE CAUSES	ACTION
Paper jam in fold roller section	Folding not selected Side joggers set too tight	Select folding on control panel Adjust side joggers correctly
Stapler jam	Stapler not aligned to anvils	Align staplers to anvil
Bad sheet alignment-side	Side joggers incorrectly adjusted	Adjust side jogger to the paper size
Bad sheet alignment-front to back	Rear jogger incorrectly adjusted Upper pressure roller missing Upper pressure roller incorrectly positioned	Adjust rear jogger Mount upper pressure roller Position the upper pressure roller to correct paper size
Not possible to select third party eject on Collator	Connection cable not attached Top cover open Power switch set to OFF position Stapler-Folder in jam condition	Attach connection cable Close top cover Set power switch to ON Clear jam in Stapler-Folder
Paper jam into side guides	Stapler-Folder incorrectly positioned to Collator Paper size setting incorrect	Reposition the Stapler-Folder for the correct paper size Adjust side joggers to the correct paper size
Paper jam in infeed area	Upper guides on side jogger unfolded Upper pressure roller incorrectly positioned Rear jogger unit lowered in on-line mode	Fold down upper guides Reposition the pressure roller Raise the rear jogger
Sheet remaining in stapling section	Lower stapler Misfeed in Collator Paper jam in Stapler-Folder Side jogger set too tight	Load stapler Correct problem in Collator and restart Clear paper jam Adjust the side joggers to the correct paper size

7. Specification

7.1 Specification table

	Model 61-TC (ON-line)	Model 61 (OFF-line)
Capacity	10 sheets 80 gsm (incl. cover) 10 sheets 20 lb bond (incl. cover)	22 sheets 80 gsm 22 sheets 20 lb bond
Speed	1350 A5 sized booklets / hour 1000 A4 sized booklets / hour	Adjustable up to 1800 A5 or 1350 A4 sized booklets / hour
Paper size	Min	200 x 270 mm, 7 ⁷ / ₈ " x 10 ⁵ / ₈ "
	Max	305 x 440 mm, 12" x 17 ¹ / ₄ "
Stapler head	210Plockmatic chisel point	
Low stapler detection	Yes	
Jam detection	Yes	
Jogging	Side and back	
Height	550 mm (880 mm incl. base) 21 ⁵ / ₈ " (34 ⁵ / ₈ " incl. base)	
Width	780 mm (1420 mm incl. Belt Stacker) 30 ¹¹ / ₁₆ " (55 ⁷ / ₈ " incl. Belt Stacker)	
Depth	500 mm 19 ⁵ / ₁₆ "	
Weight	58 kg 128 lb	
Voltage	115V 60 Hz 230/240V 50 Hz	

