





Children must not operate the machine!



Never leave the blade unattended. Do not extract or transport the blade without protection!
⚠ Danger! Risk of injury!



Do not reach beneath the blade!



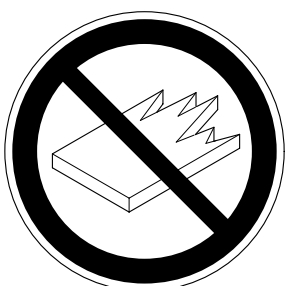

Paper clips or hard material will damage the cutting blade!



Do not cut hard materials or materials which may splinter!

Table of contents

1. General	4
1.1 Safety Precautions  	4
1.2 Application	4
2. Installation	5
2.1 Preparing for installation	5
2.2 Power supply	6
3. Operation	7
Checklist	7
3.1 Operating elements	8
3.2 Start-up	8
Manual foot pedal	8
Cutting to a specified dimension	8
Calculating:	9
Cut according to markings	9
Optical cutting line indicator	9
Mechanical cutting line indicator	9
Eject function	9
Multiple cuts function start	10
Exiting program-mode	10
3.3 Cutting activation	10
Cutting stop or interruption:	10
3.4 False clamp plate	11
3.5 Programming	12
Entering a program	12
Eject function program	12
Changing select program	13
Insert a step	13
Delete a step	13
Delete a program	13
Example of a program	13
How the example works	13
Changing the basic settings	13
Working with programs	14
Exiting program-mode	14
3.6 Basic Settings	14
4. Maintenance	15
Safety check	15
4.1 Setting the cutting depth	15
4.2 Turning or replacing the cutting stick	16
Cutting test	16
4.3 Blade replacement	17
Removing the blade	17
Mounting the blade	18
4.4 Maintenance every 7 days	19
4.5 Maintenance every 6 months	19
Type of grease	19
5. Malfunctions	20
6. Technical data	22
7. Accessories	22
EC-declaration of conformity	23

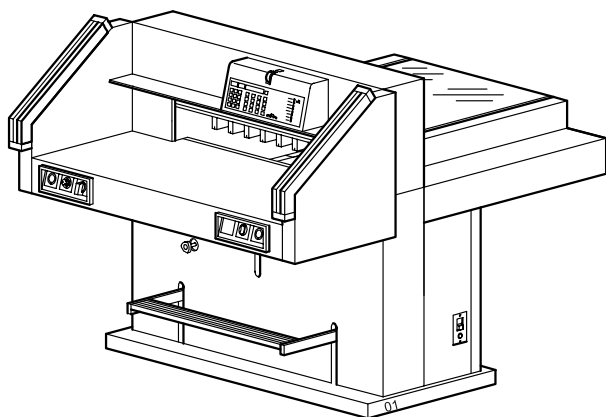

without side tables

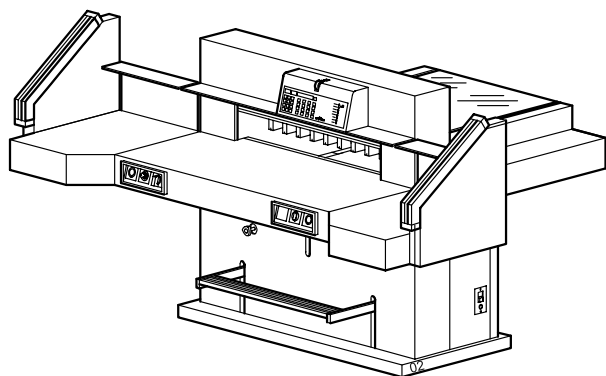

with side tables

1. General

This instruction manual will help you to learn the safe and comfortable operation of this machine. Please read these operating instructions before putting the machine into operation and observe the safety regulations.

1.1 Safety Precautions

Danger!

Non-compliance with the instructions may endanger persons.

Warning!

Non-compliance with the instructions may cause damage to the machine.

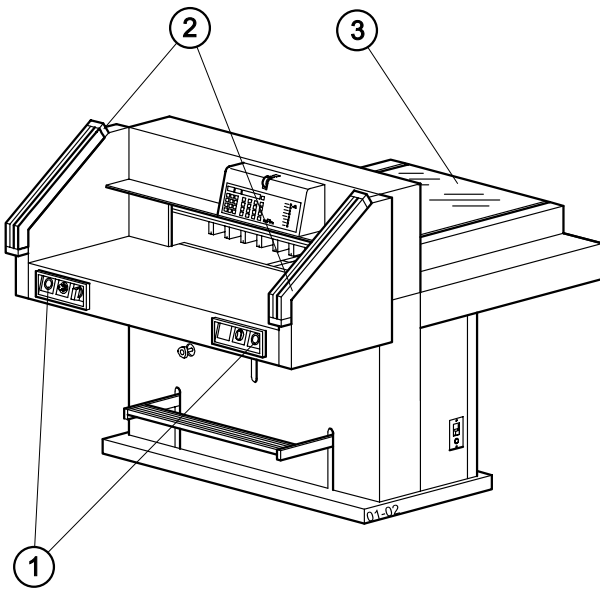

The operating instructions must always be available for the operator.

All components which could endanger the operator are covered by a guard. The side panels are screwed to the machine.

This machine is constructed for "one-man operation" only!

The dangerous cutting movement is safeguarded by a cover (3), a two-handed control system (2) and a safety beam guard (1).

1.2 Application

The machine is designed for cutting stacks of paper to a specified size. Setting the measurement is done via buttons or hand wheel. Cutting is released by a "two-handed control system".

Danger!

Only instructed persons are allowed to operate the machine.

Children must not operate the machine!

Danger!

Do not cut hard materials or materials which may splinter.

Warning!

The machine may only be used for cutting paper or similar materials. Paper clips or hard material will damage the cutting blade.

2. Installation

- Transport the machine on the pallet to its destination using a pallet truck.
- 6 strong people are required to lift the machine from the pallet.
- The machine must be installed on a sturdy, dry and level floor.

⚠ Danger!

- The machine must not be located outside.
- Do not use in the vicinity of inflammable liquids or gases.
- Do not use in humid environments.
- Protect mains cable against heat, oil and sharp edges.

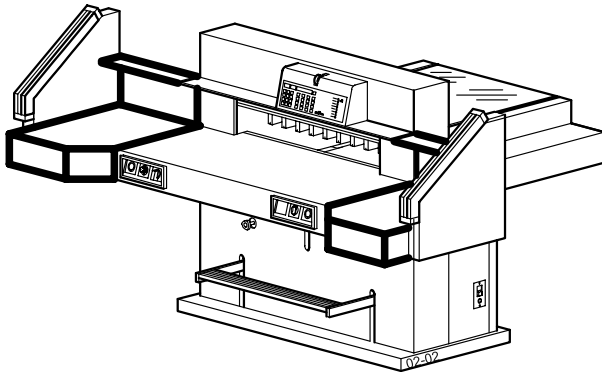

2.1 Preparing for installation

The machine is delivered ready for operation. As an option, side tables, left and right, are available. These should be mounted so that the surfaces are level with the main table.

⚠ Danger!

The machine must not be put into operation without the safety light beam.

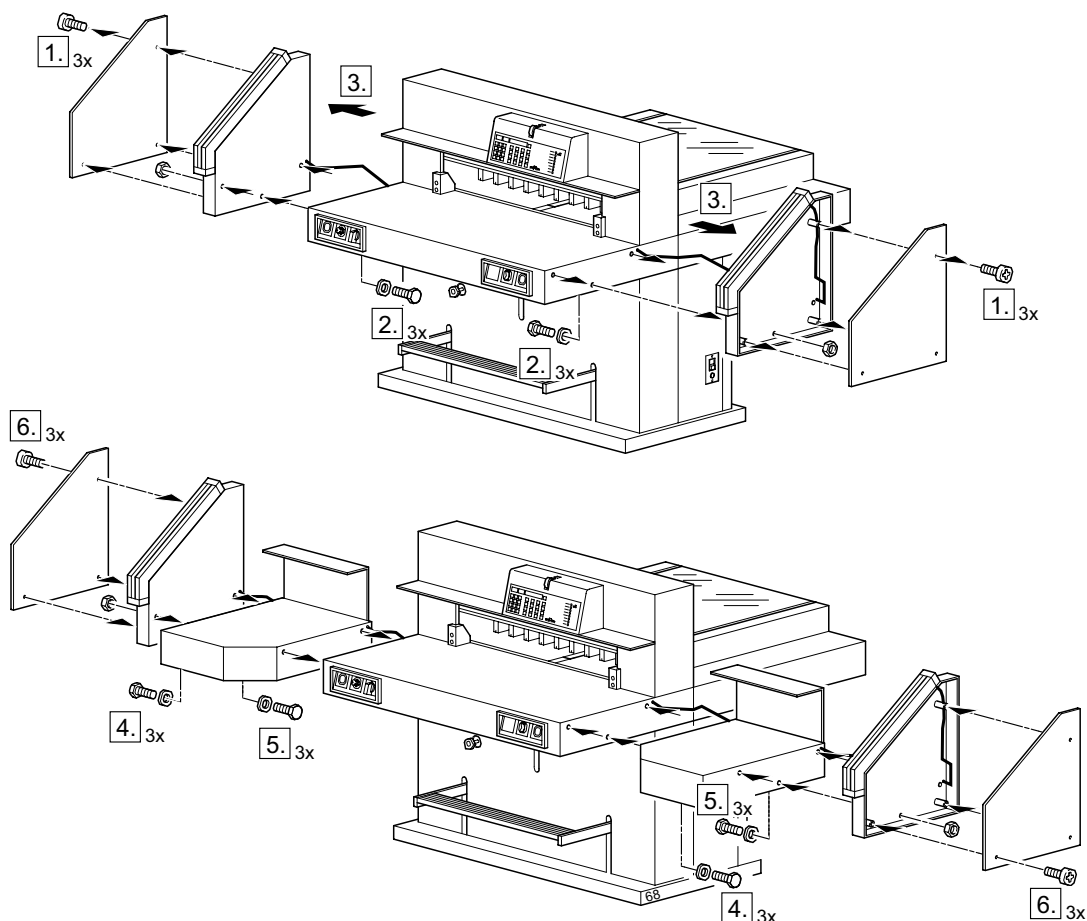

2.2 Power supply

The name plate (23) is located at the rear of the machine.

- Data stated on the name plate
 - Voltage "V",
 - Frequency "Hz",
 - Power consumption "A"
 must correspond to the values of the power supply unit.
- Connect the machine to the mains.
- **Earth wire must be available.**

Standard machines are factory-set as follows:

- Voltage 400V (220V) 3 phase
- Frequency 50Hz (60Hz).

Machine does not function

- Machine (5) is switched on?
- Key-switch (4) on?
- Green overload switch (36) is pressed?
- Black overload switch (37) is pressed?
- Check on-site fuse.

If the machine still does not function then the rotation must be reversed.

The machine is wired according to the IEC standards. We recommend that alterations to the rotary direction be made in the socket. It is also possible to make alterations in the plug by exchanging "L1" and "L2".

⚠ Danger!

Incorrect exchanging of the connections will endanger the operator. This work must be carried out by an electrician.

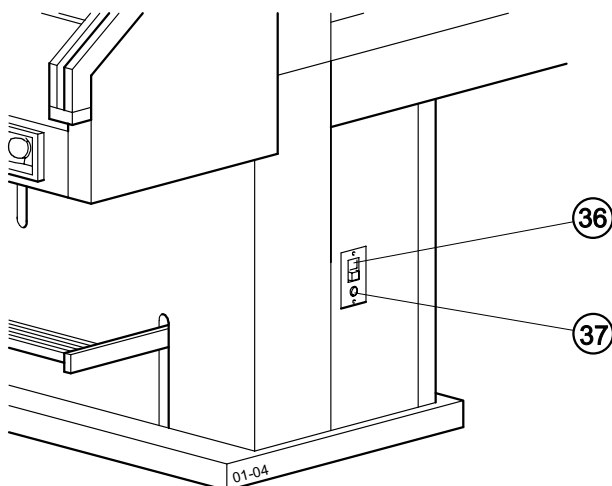
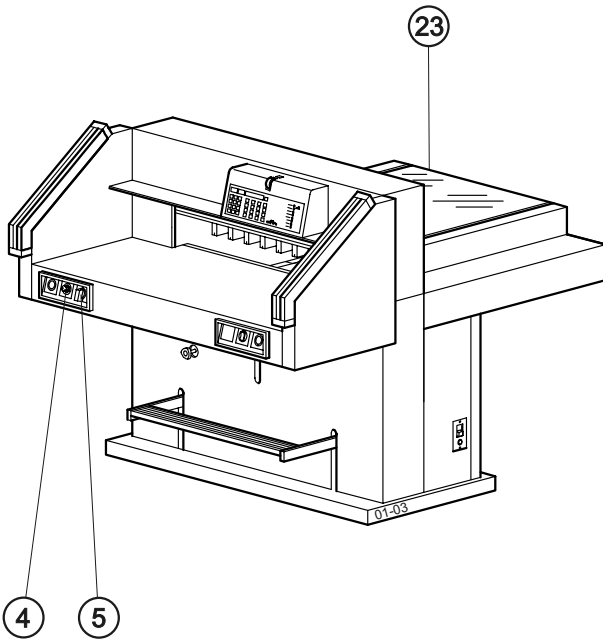

3. Operation

⚠ Danger!

It is forbidden to operate the machine if the operating and safety instructions have not been understood.

⚠ Danger!

Please check the safety devices are functioning and complete before use and after replacing the blade.

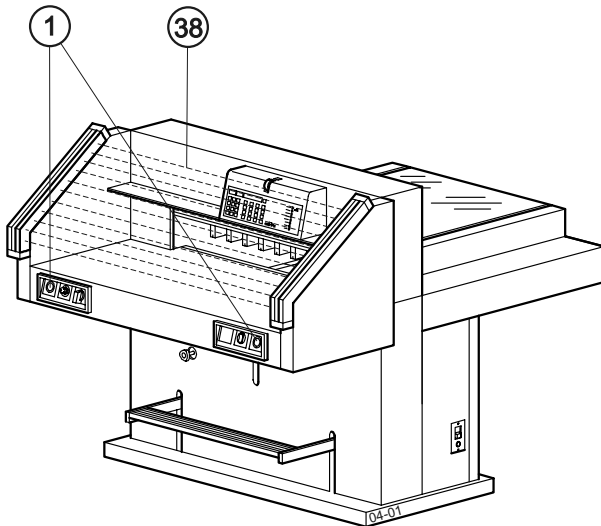

Checklist

- Machine panels:
All panels have to be mounted
- Cutting activation:
The release for cutting is allowed only if the "two-hand safety device" (1) is operated at the same time.
- Safety light beam
Do not reach into the cutting area (38) when in motion.

We recommend you keep a record of your test results.

Cutting sequence (1) with automatic clamping:

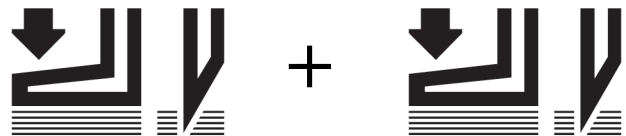

Airtable (9) optional

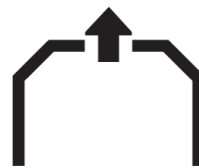

The airtable allows paper to be easily positioned.

Setting clamping pressure (7)



The clamp pressure can be adjusted using the adjustment knob (7).

→ The clamping pressure can be read on the light panel (19).

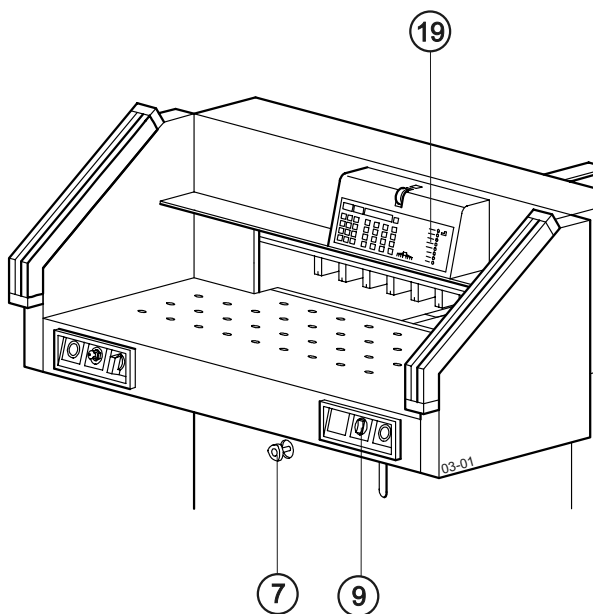

3.1 Operating elements

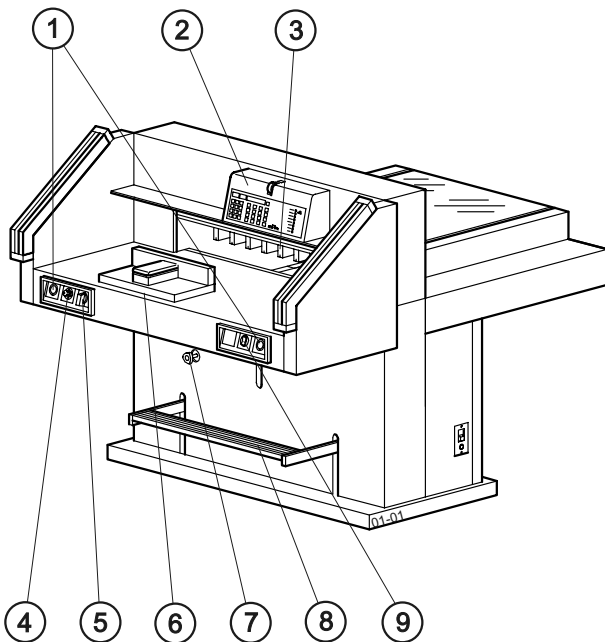

- (1) Safety two-handed control system
- (2) Backgauge control
- (3) Backgauge
- (4) Key switch
- (5) Main switch
- (6) Paper knock-up block
- (7) Clamp pressure adjustment
- (8) Foot pedal
- (9) Airtable switch
- (10) Program number
- (11) Program step
- (12) LED "M" display memory
- (13) LED "E" display eject
- (14) LED "S" display error indication
- (15) Display cutting size
- (16) Backgauge, backwards fast
- (17) Electronical hand-wheel for fine adjustment
- (18) Backgauge, forwards fast
- (19) Clamp pressure
- (20) Program keys
- (21) Basic setting F1, F2, F3, eject
- (22) Display false clamp plate
- (23) Keypad with calculator
- (24) Display impuls of backgauge movement
- (25) Display in cm or inch
- (26) Changeover cm-inch.

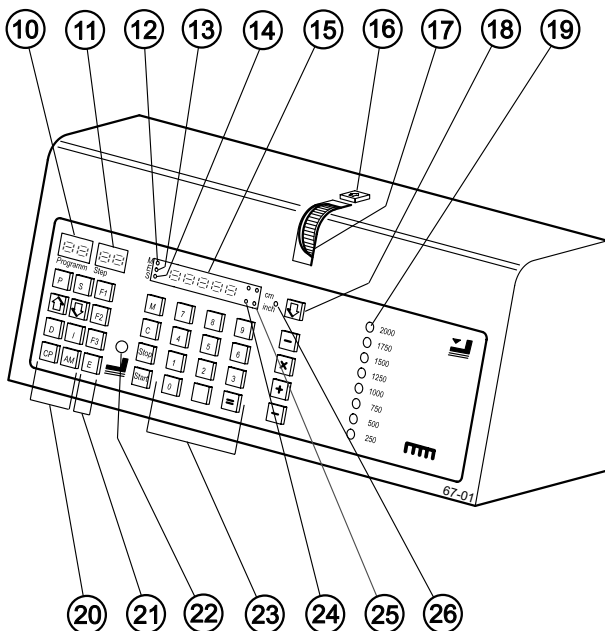

3.2 Start-up

- Position the main switch (5) to "I".
- Insert the key (4) for the control panel and turn to the right.
- Press **Start** button → backgauge (3) moves to the rear and searches for the reference position, wait until a measurement is shown on the display.

Manual foot pedal

Pre-clamping can be performed using the foot pedal (8) (e.g. folded stacks).

Cutting to a specified dimension

- Enter dimension on the numerical key → LED "S" (14) appears.
- Press **Start** button → dimension is approached, LED "S" disappears.
- Insert paper and move by means of the paper knock-up block to the backgauge (6).
- Release the cut (see 3.3 "Cutting activation").

Calculating:

e.g. $\boxed{2} \boxed{0} \boxed{-} \boxed{2} \text{ [Start]}$ → Backgauge advances to the calculated measurement of 18.

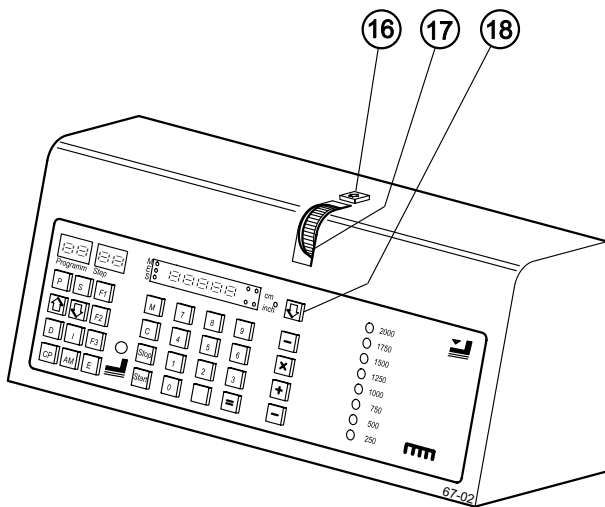

Cut according to markings

- Adjust the backgauge (16) to the back.
- Insert paper and move by means of the paper knock-up block to the backgauge.
- Turn the hand-wheel (17) to the front until the marking on the paper to be cut is below the cutting line indicator. The more the hand-wheel is turned the faster the backgauge will move. For quick motion use key (18).
- Release the cut.

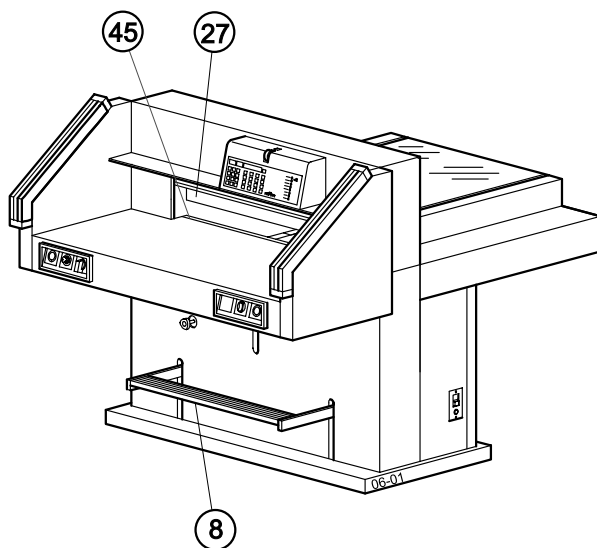

Optical cutting line indicator

An optical cutting line (45) indicates the exact position of the cut. The light beam indicates where the cut will be made.

Mechanical cutting line indicator

The clamp (24) can be used as cutting line indicator for exact cutting. Pre-clamping can be performed using the foot pedal (8).

Eject function

If button \boxed{E} is pressed, the backgauge will advance to the preset measurement, ejecting the material to be cut, then automatically return to the position shown on the display.

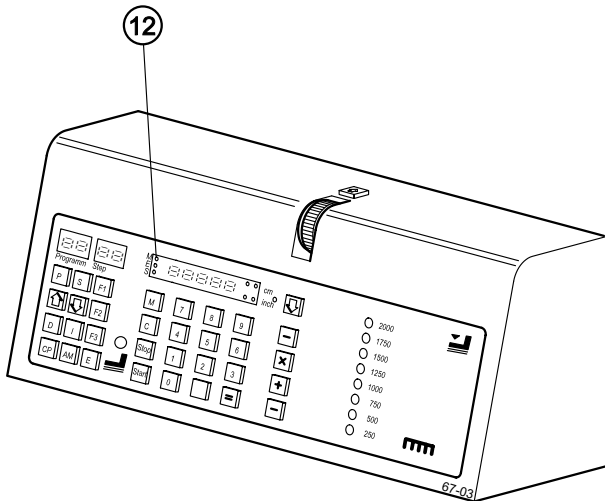

Multiple cuts function start

- Enter the cut size on the display.
- Press **Start** button → advances to the measurement.
- Push the paper to the backgauge.
- Release the cut.
- Press **AM** button → "A" appears on the middle display.
- Enter the multiple cut size.
- Press **Start** button → backgauge will advance by the multiple cut size.
- After the cut the backgauge advances to the next multiple cut size.

If, when inserting the multiple cut size, the **M** button is pressed instead of the **AM** button the LED "M" (12) will light and after every cut the **Start** button must be pressed.

Exiting program-mode

- Press **M** button → LED "M" (12) is cleared on the display. The actual size is shown.

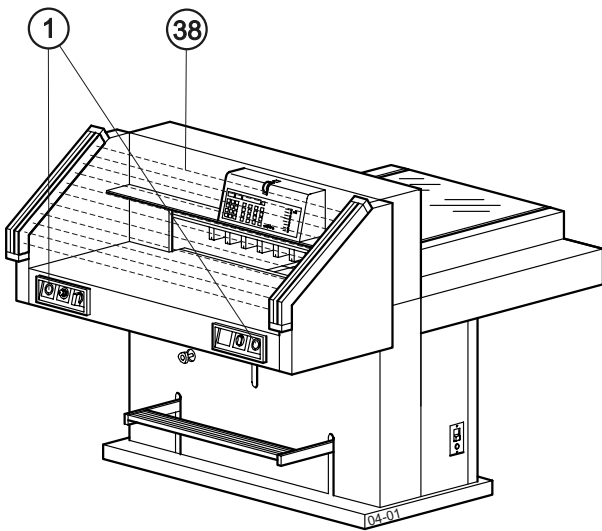

3.3 Cutting activation

⚠ Danger!

Do not reach into the cutting area when the blade is in motion.

A cut can only be activated when the specified size is approached. The LED "S" on the display must be deleted and the safety area (38) free.

- Press both buttons of the safety two-handed control system (1) simultaneously and keep them pressed until the paper is completely cut.

Cutting stop or interruption:

- Release both buttons of the two-hand control (1).

3.4 False clamp plate

A cover plate (39) can be fitted to prevent pressure marks on sensitive material. The LED (22) light is on when the cover plate is fitted.

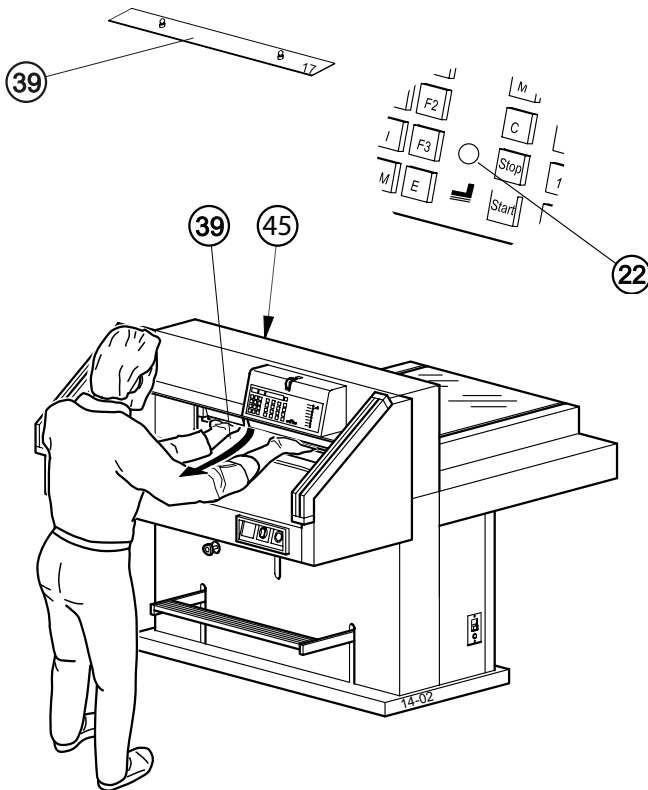

To dismount:

- Remove the clamp plate (39) by pulling it down
- Store the clamp plate in the provided holder (45)
- The remaining cut is 2 cm.





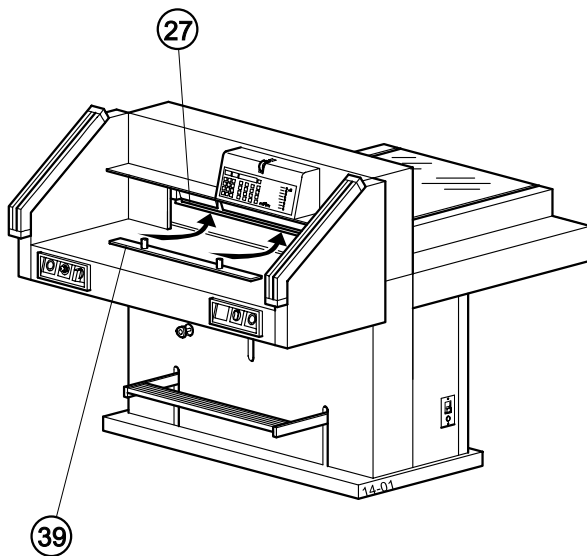





To mount:

- The clamp plate (39) is inserted to the top into the clamp (24) → The remaining cut is 9 cm











3.5 Programming

This control system enables you to store 40 programs with 36 programmable steps. One step represents one measurement or max. 9 multiple cuts.

-  Program
-  Step
-  Memory (multiple cut)
-  Memory (multiple cut with automatic control after the cut)
-  Program up
-  Program down
-  Clear
-  Delete
-  Insert
-  Eject
-  Clear Program



The indicated program step can be overwritten at any time. These programs remain stored when the machine is off. Should you change to another dimension unit all programmed measures are converted into the new unit (cm and inch).

Entering a program



- Press  → "P" appears on the display.
- Enter program number  ... . → The number will be shown on the display (10). If measurement is shown on the display (15) the program is reserved.
- Enter a measurement or advance with the hand-wheel.
-  Store the measurement.
- Enter the next measurement.
-  Store the measurement.
-   Escape the program mode.

Eject function program

This eject function can be added each time a measurement is entered and ejects before advancing to the next measurement.

- Enter the measurement.
- Press  → LED "E" appears.
- Press 

Multiple cut program

- Press  until the multiple cut size is reached. Maximum 9 multiple cuts can be entered.
- Enter multiple cut size.
-  Store the dimension.

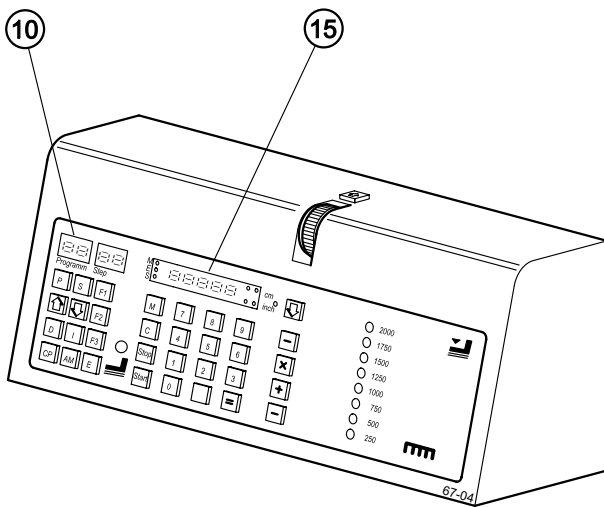

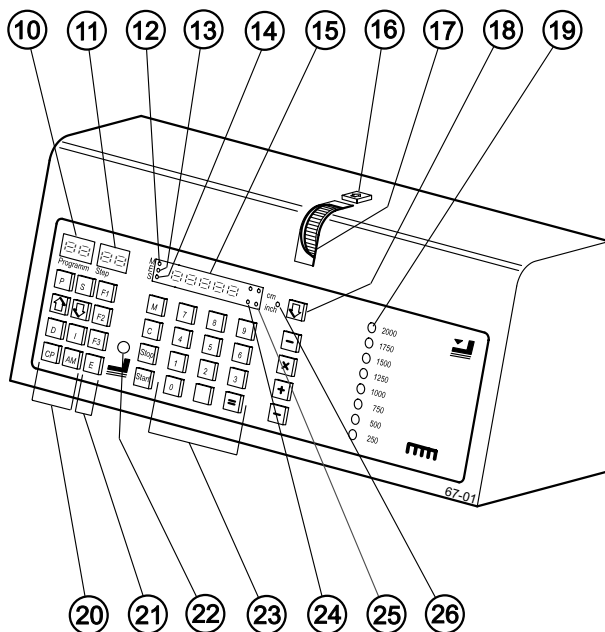

Changing select program

- Press **P** → "PR" appears on the display.
- Enter desired program number **0 1...4 0**.
- Press **S**
- Enter step number **0 1...3 6**.
- Or enter the next program step with button **▲** or **▼**.

Insert a step

The program step is entered first.

- Choose a step number with button **▲** or **▼**
- Press button **I**.
- Enter measurement.
- Press button **=**.

Delete a step

- Choose a step number with button **▲** or **▼**
- Press button **D** twice

Delete a program

- Enter program number **0 1...4 0**.
- Press button **CP** twice

Example of a program

- **P 0 8** program 08
- **CP CP** delete previous program
- **1 9 =** step 1 on 19,0cm
- **2 7** step 2 on 27,0cm
- **E =** eject
- **P Stop** escape the program mode

How the example works

- **P 0 8** start program 08
- **Start** proceed to position
- Insert paper
- Release cut 1
- Paper is ejected
- Release cut 2
- **P Stop** escape the program mode.

Changing the basic settings

Frequently used measurements are stored in the control system.

- **F1** Basic setting 21 cm (8,267").
- **F2** Basic setting 14,85 cm (5,846").
- **F3** Basic setting 10,5 cm (4,133").
- **E** (Eject) Basic setting 20 cm (7,87")

Changing a basic setting:

- Press **P** + **F1** → setting blinks.
- Enter new setting.
- Press **=** → setting is stored.

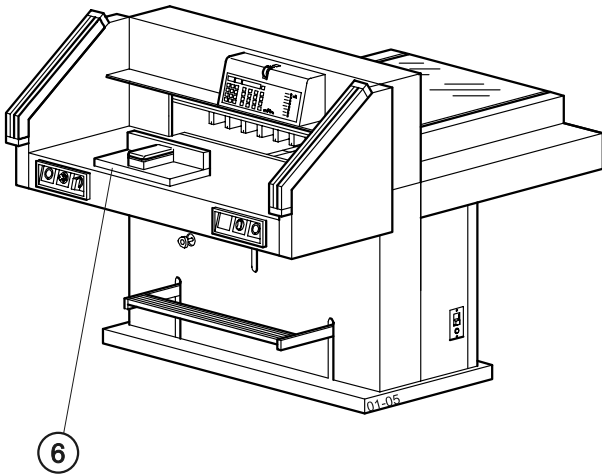

Working with programs

- Press **[P]**.
- Enter program number **[0][1]...[4][0]**.
- Press **[Start]** → proceeds to position.
- Insert the paper and push it with the paper knock-up block (6) to the backgauge.
- Release the cut → after every cut the backgauge advances to the next position.

The cutting activation is described under No. "3.3 Cutting activation".

With buttons **[▲]** and **[▼]** you are able to change between several program steps.

With **[Start]** the backgauge moves to the indicated dimension.

With **[Stop]** the backgauge stops.

LED "S" is on → specified dimension not achieved.

LED "S" is off → specified dimension achieved.

[Stop] button is pressed - backgauge stops and the actual dimension is shown.

Exiting program-mode.

Press **[P]** **[Stop]**

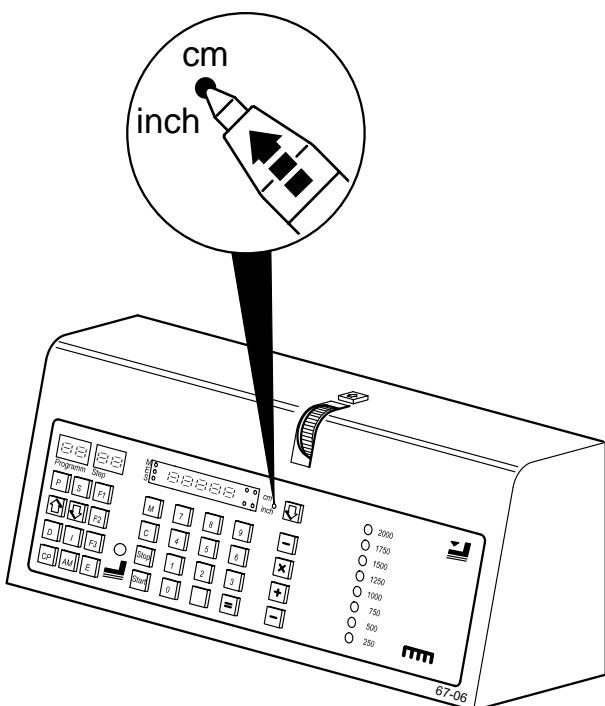

3.6 Basic Settings

Display in cm or inch

Press **[cm-inch]** → display changes between cm and inch. The corresponding LED light will be on.

Display brightness

Press **[cm-inch]** + **[D]** display changes between light and dark.

Cutting counter

Press **[cm-inch]** + **[S]** number of cuts are shown.

Press **[D]** twice to delete the counter.

Press **[Stop]** to escape the program mode

4. Maintenance

⚠ Danger!

- Maintenance work may only be performed by trained staff.
- Before replacing the blade or cutting stick switch off the main switch.
- **Disconnect from the mains before starting any service work or before removing the cover.**

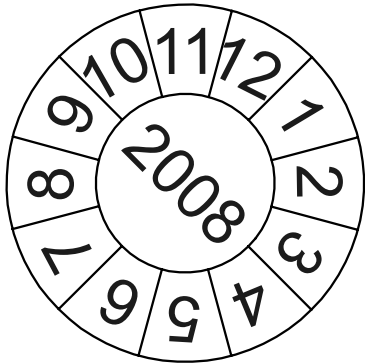

Safety check

The safety regulations are according to the regulations of the country where the cutting machine is operated. The manufacturer recommends a safety check is made every 5 years by an authorised service team.

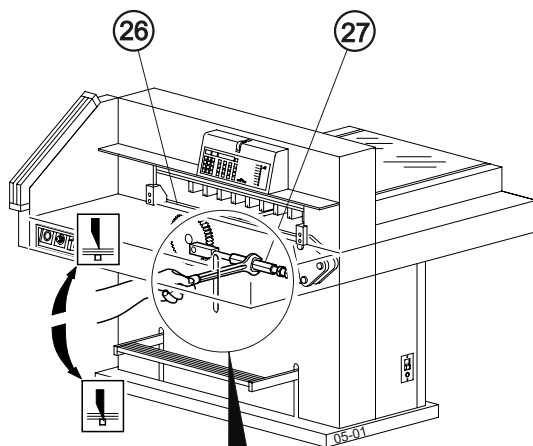

4.1 Setting the cutting depth

If the last sheet of paper is not completely cut, the cutting depth must be adjusted.

- Lower the blade depth adjustment (27) 1/12 using a spanner.
- Remove spanner.
- Perform cutting test as described.

If the cutting stick (26) is very worn it must be turned.

⚠ Warning!

Do not cut into the cutting stick too deep as this shortens the life time of the blade.

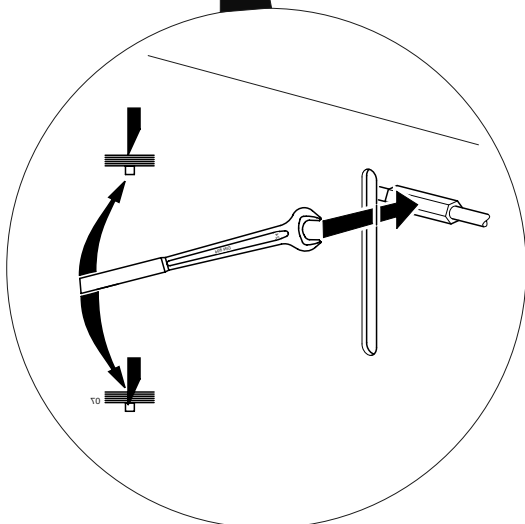

4.2 Turning or replacing the cutting stick

- Turn the blade depth adjustment (27) to the top until it stops (spanner in tool set).

- Remove spanner.

⚠ Danger! Risk of injury!

- Take out the cutting stick (26) with a small screwdriver.

- Turn the cutting stick (the non-used side must be near to the blade) and plug it into the holding bolt. The cutting stick can be used eight times.

- Put a sheet of paper onto the whole width of the cutting area.

- Lower the blade by pressing both cut buttons. Keep one button pressed and turn main switch to position "0".

- Lower the blade depth adjustment (27) until the paper is cut along the entire length.

- Remove spanner.

- Turn main switch to position "I".

Cutting test

- Put a sheet of paper onto the whole width of the cutting area.

- If the sheet of paper is not completely cut, lower the blade adjustment (27) 1/12 using the spanner.

- Remove spanner.

- Repeat this procedure until the paper is cut along the entire length.

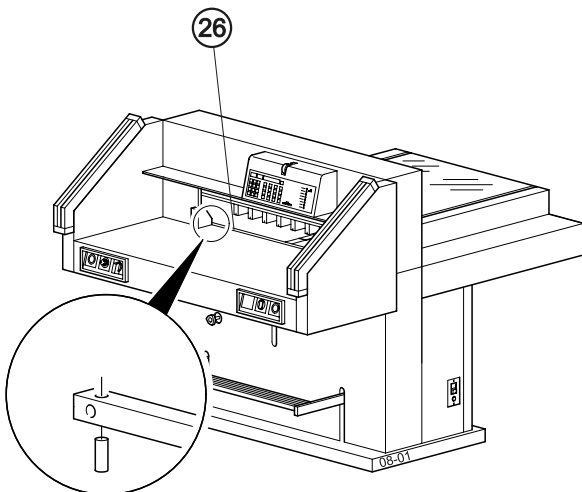
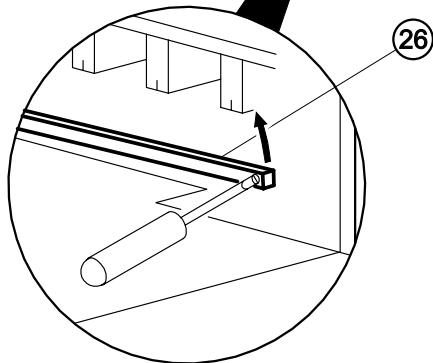
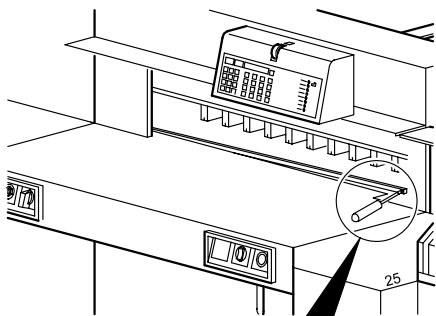
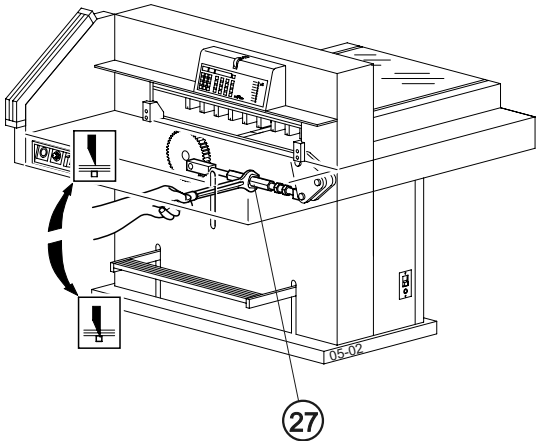

4.3 Blade replacement

A reduction in the cutting quality indicates that the blade must be sharpened or a blade change is necessary.

⚠ Danger! Risk of injury!

- **The blade is extremely sharp. Do not remove or transport the blade without protection.**
- Changing the blade may only be performed by trained staff.

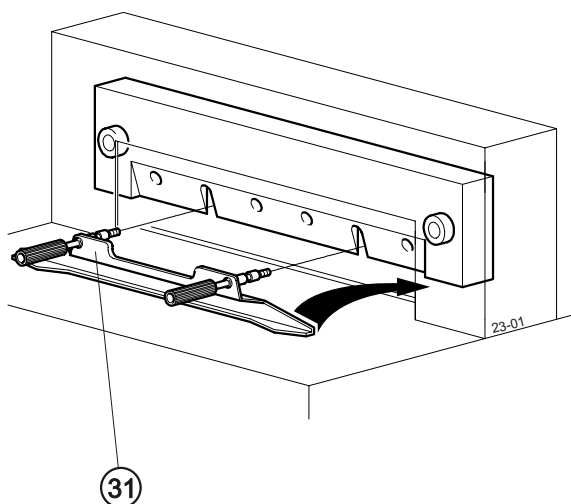
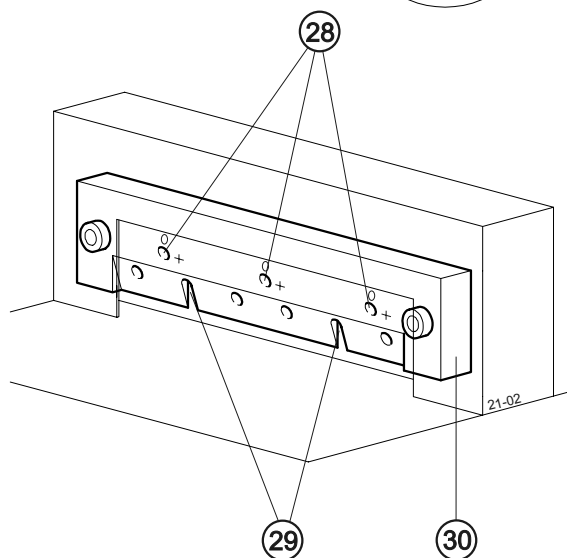
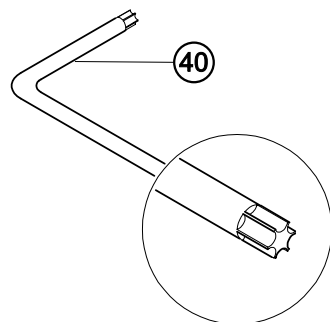
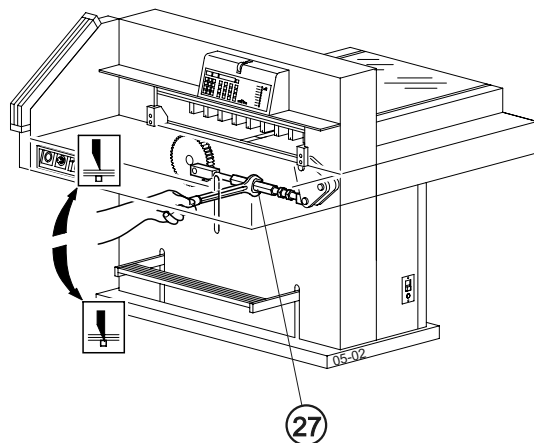

Removing the blade

- Turn the blade depth adjustment (27) to the top until it stops (spanner in tool set).
- Remove spanner.
- Lower the blade by pressing both cut buttons. Keep one button pressed and turn the main switch to position "0".
- The eccentrics (28) are now exposed and should be turned to position "0". The special wrench (40) is in the tool set.
- Remove the special wrench.
- Turn main switch to position "I".
- Wait until the blade is at the top.
- Turn main switch to position "0".
- Remove the 2 blade screws (29).
- Put the blade changing tool (31) into place and fasten it to the blade.
- Remove remaining screws.
- Loosen the grips of the blade changing tool (31) lightly.
- Allow the blade to be taken downwards out of the machine.
- Place the blade into the blade carrier and screw it into place.

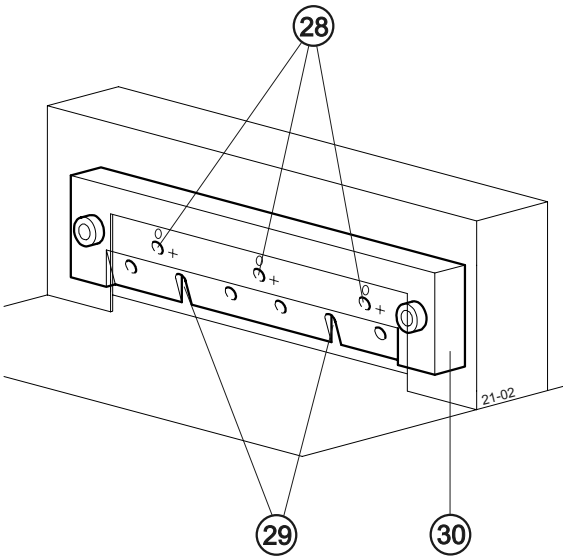
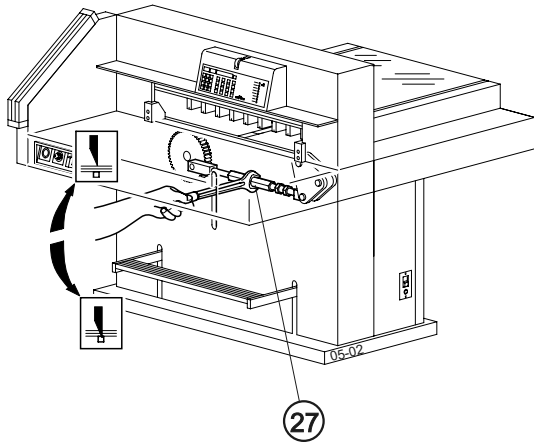
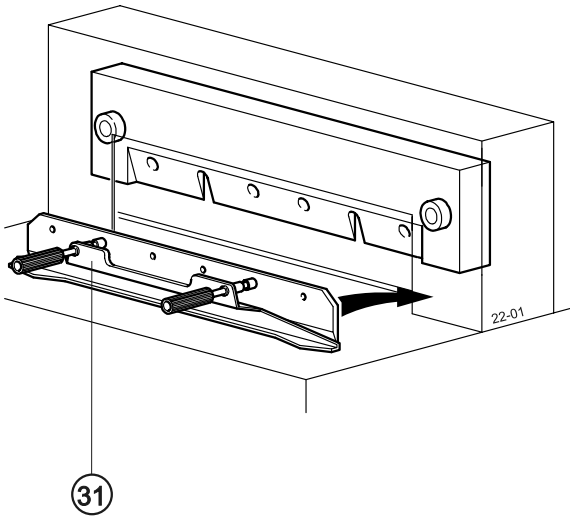

Mounting the blade

- Turn or replace the cutting stick → see „Turning or replacing the cutting stick“.
- Push the replacement blade with the blade changing tool (31) mounted into the blade carrier (30) to the top and screw into place with the grips.
- Lightly tighten 4 of the 6 blade screws (29) (with washers).
- Remove the blade changing tool.
- Lightly tighten the remaining blade screws (with washers) (2).
- Remove all tools.
- Position a sheet of paper along the entire cutting length.
- Lower the blade by pressing both cut buttons. Keep one button pressed and turn off the main switch.
- Lower the blade depth adjustment (27) until the blade touches the paper.
- The 3 eccentrics (28) should then be used to lower the blade until the paper is cut along the entire length of the blade → (The blade must remain parallel to the cutting stick).
- Turn main switch to position "I".
- When the blade is in the upper position tighten the 6 blade screws firmly.
- Cut a stack of paper to test.

The blade cannot be ground if the blade height is 82 mm/ 3,23 inches a new blade must be used.

⚠ Warning!

Blades may only be sharpened by a specialist.

4.4 Maintenance every 7 days

- Advance the backgauge as far as possible to the front.
- Lubricate the grease nipple (32).

Type of grease

- Non-resinous oil or grease.

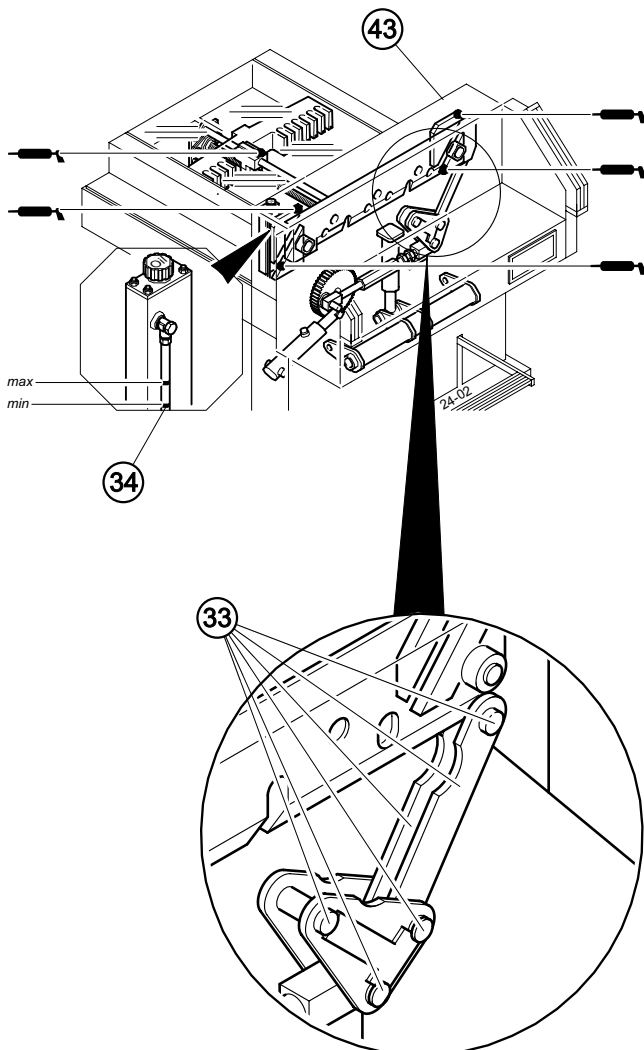
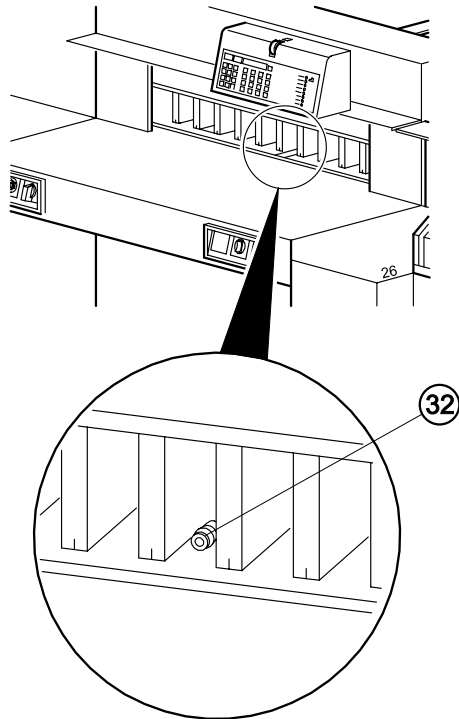

4.5 Maintenance every 6 months

- Turn main switch off.
- Disconnect from the mains.
- Remove the front upper housing (43) → taking care of the cable.
- Check oil (34). If oil is below minimum contact your dealer.
- Remove paper debris.
- Lubricate all grease nipples.
- Check the 4 joining bolts and 2 pushing bars (33) for wear.
- If necessary inform your service personnel.
- Reassemble the machine.

If the machine is used more than 10 hours per day maintenance work must be more frequent.

Type of grease

- Non-resinous oil or grease.

5. Malfunctions

⚠ Danger!
Disconnect from the mains before starting any service work or before removing the cover. Afterwards attach the covers.

Malfunction:

Display illumination off.

Cause:

Power supply.

Remedy:

- Machine is plugged in?
- Main switch is on?
- Green overload switch (36) is pressed?
- Key switch on?
- Check the units fuse and the on-site circuit breaker!

Malfunction:

Optical cutting line indicator does not function after the machine has been moved to another position.

Cause:

Phase direction wrong.

Remedy:

See "Installation and Power supply".

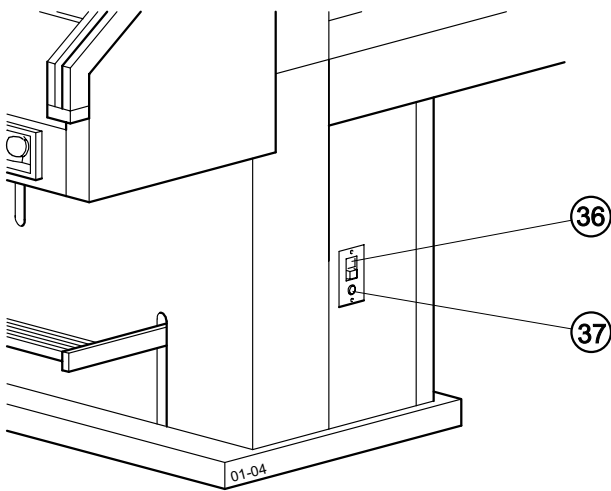

Malfunction:

Backgauge blocked.

Cause:

Motor is overloaded.

Remedy:

Press safety switch (37).

Malfunction:

Cut cannot be activated.

a) Cause:

Safety light beam is interrupted / dirty?

Remedy:

Remove any items and clean the sender.

b) Cause:

Measurement has not been reached correctly.

→ LED "S" does not turn off.

Remedy:

Press **Start** again.

c) Cause:

Size under 9 cm.

Remedy:

Put the false clamp in the provided holder.

Malfunction:

Machine is switched on but cut cannot be made.

Cause:

Safety clutch is activated.

Remedy:

Contact your dealer.

Malfunction:

Does not cut through the last sheet.

Remedy:

Adjust replace or turn the cutting stick (see Cutting stick).

Malfunction:

Poor cutting quality or blade stays in the paper stack.

Remedy:

Change the blade or adjust as necessary.

Malfunction:

No clamp pressure

Cause:

Hydraulic oil needs refilling

Remedy:

Contact your dealer.

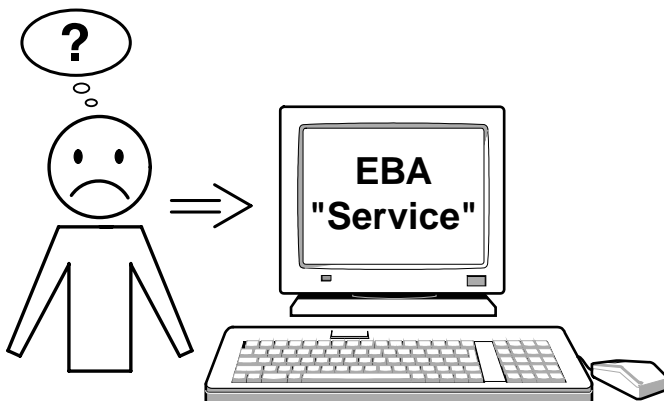

If you have further questions please contact your dealer or directly on the internet www.eba.de
→ "service" service@krug-priester.com

Subject to alteration without notice

6. Technical data

Height of blade	> 82 mm.
Sound level DIN 45635-27:	max. 70 dB(A)
Minimum space requirement w x d:	
without side tables	130 cm x 151 cm
with side tables	210 cm x 160 cm
Clamping pressure	250 dN bis 2000 dN
Weight without side tables:	613 kg
Weight with side tables:	620 kg
Capacity of hydraulic oil	
Shell Tellus C32 or similar	1,5 l
Used oil must be disposed of at the authorised place.	

The exact technical specifications can be found on the technical specifications sticker on the machine.

Safety light beam

Total reaction time of safety device:	95 ms
Resolution top	20 mm; 30 mm
Resolution front	40 mm
Minimum distance:	238 mm; 20 mm
Minimum distance:	318 mm; 30 mm
Minimum distance:	460 mm; 40 mm

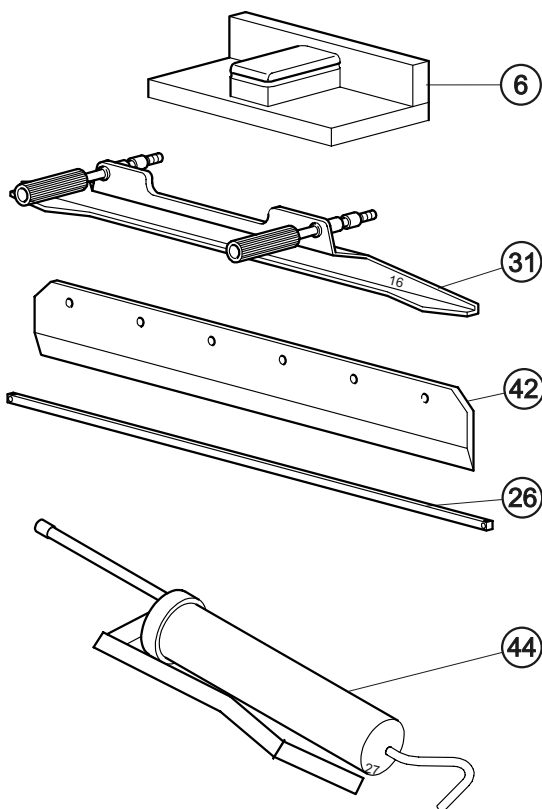

7. Accessories



Attention!

Only use accessories recommended by the manufacturer.

Paper knock-up block (6)	9000 521
Blade changing tool (31)	9000 514
Grease gun (44)	9004 683
* HSS - Blade (42)	9000 141
* 6 Cutting sticks (26)	9000 039
* Side tables left and right	9000 550

Accessories marked * must be ordered separately.

EG-KONFORMITÄTSERKLÄRUNG

EC-declaration of conformity

Déclaration de conformité CE

Declaración CE de conformidad

Dichiarazione CE di conformità

EG-verklaring van overeenstemming

Declaração CE de conformidade

EF-overensstemmelseserklæring

- Hiermit erklären wir, daß die Bauart von

- Herewith we declare that

- Par la présente, nous déclarons que

- Por la presente, declaramos que la

- Si dichiara che il modello della

- Hiermede verklaren wij, dat de in de handel gebrachte machine

- Com a presente, declaramos que o modelo da

- Hermed erklæres, at produkttypen

721-05 LT

- **folgenden einschlägigen Bestimmungen entspricht:**

- complies with the following provisions applying to it:

- est conforme aux dispositions pertinentes suivantes:

- satisface las disposiciones pertinentes siguientes:

- è conforme alle seguenti disposizioni pertinenti:

- voldoet aan de eisen van de in het vervolg genoemde bepalingen:

- está em conformidade com as disposições pertinentes, a saber:

- er i overensstemmelse med følgende bestemmelser:

EG 98-37; EG 73/23; EG 89/336

- **Angewendete harmonisierte Normen insbesondere**

- Applied harmonized standards in particular

- Normes harmonisées utilisées, notamment

- Normas armonizadas utilizadas particularmente

- Norme armonizzate applicate in particolare

- Gebruikte geharmoniseerde normen, in het bijzondere

- Normas harmonizadas utilizadas, em particular

- Harmoniserede standarder, der blev anvendt, i særdaleshed

EN 60204-1; prEN 1010-1; EN 1010-3;

EN 55014-1; EN 55014-2; EN 50100-1; EN 50100-2;

EN ISO 12100-1; EN ISO 12100-2; EN 294; ISO 7779

Krug & Priester GmbH u. Co KG
72336 Balingen, Germany

26. 10. 2004
Datum

W. Priester
Wolfgang Priester
- General Manager -



QUALITÄTSMANAGEMENTSYSTEM



DIN EN ISO 9001 Reg.-Nr. 1489 QM

