

# Mod.4860 ET A

01.07.2012

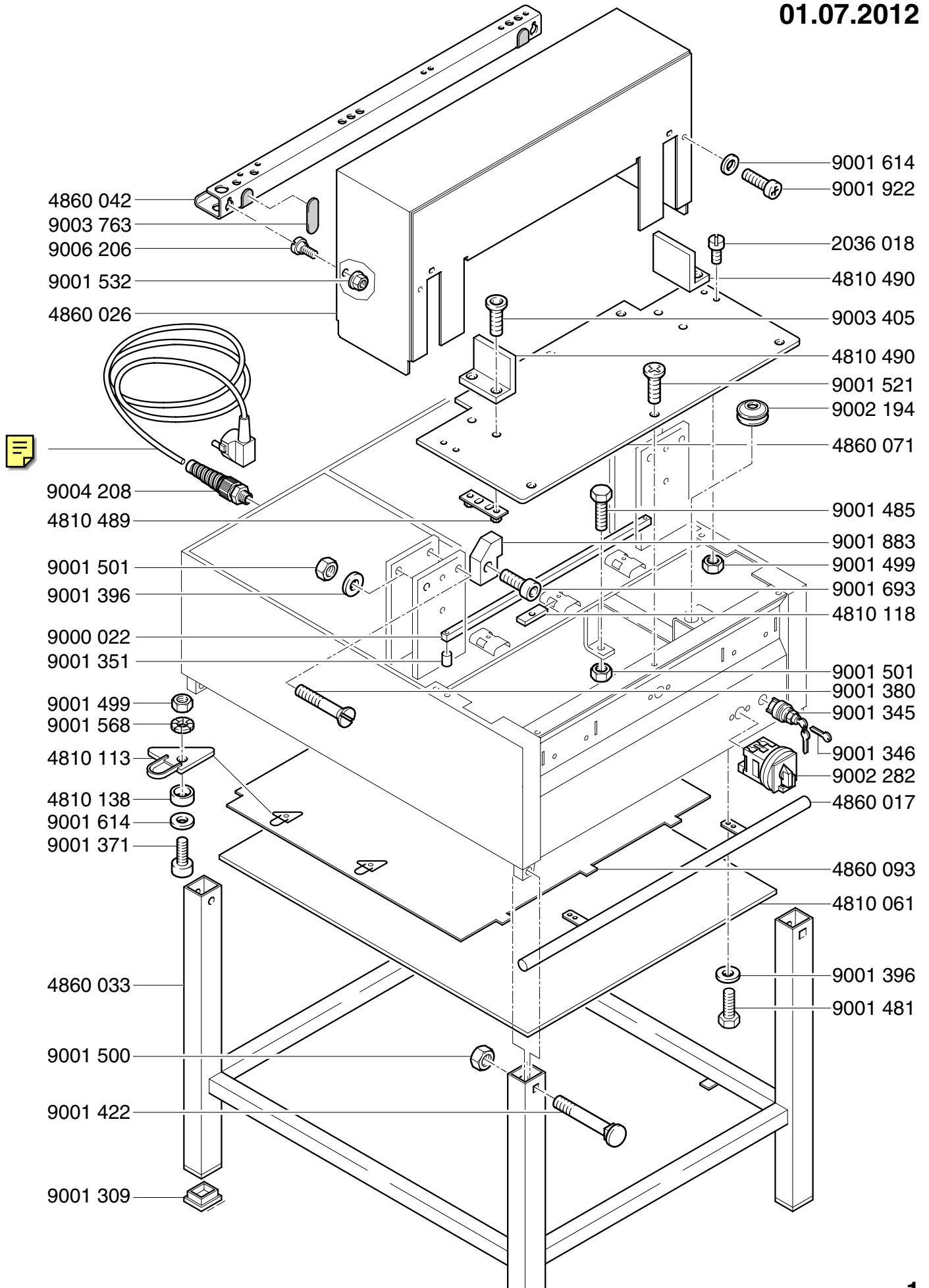

# Mod.4860 ET A

01.07.2012

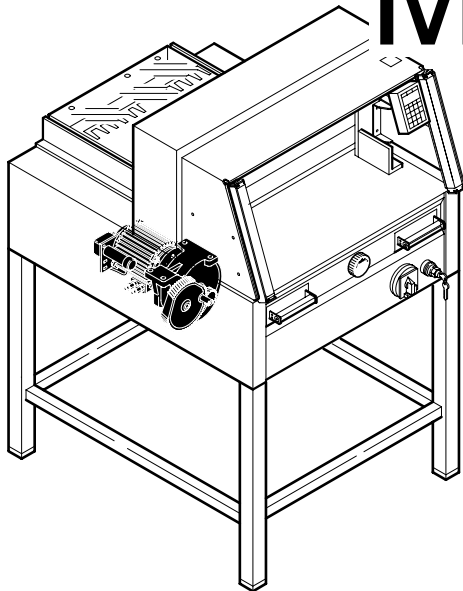

- 4860 125/100V/50-60Hz
- 4860 117/120V/60Hz
- 4860 116/220V/60Hz
- 4860 106/230V/50Hz

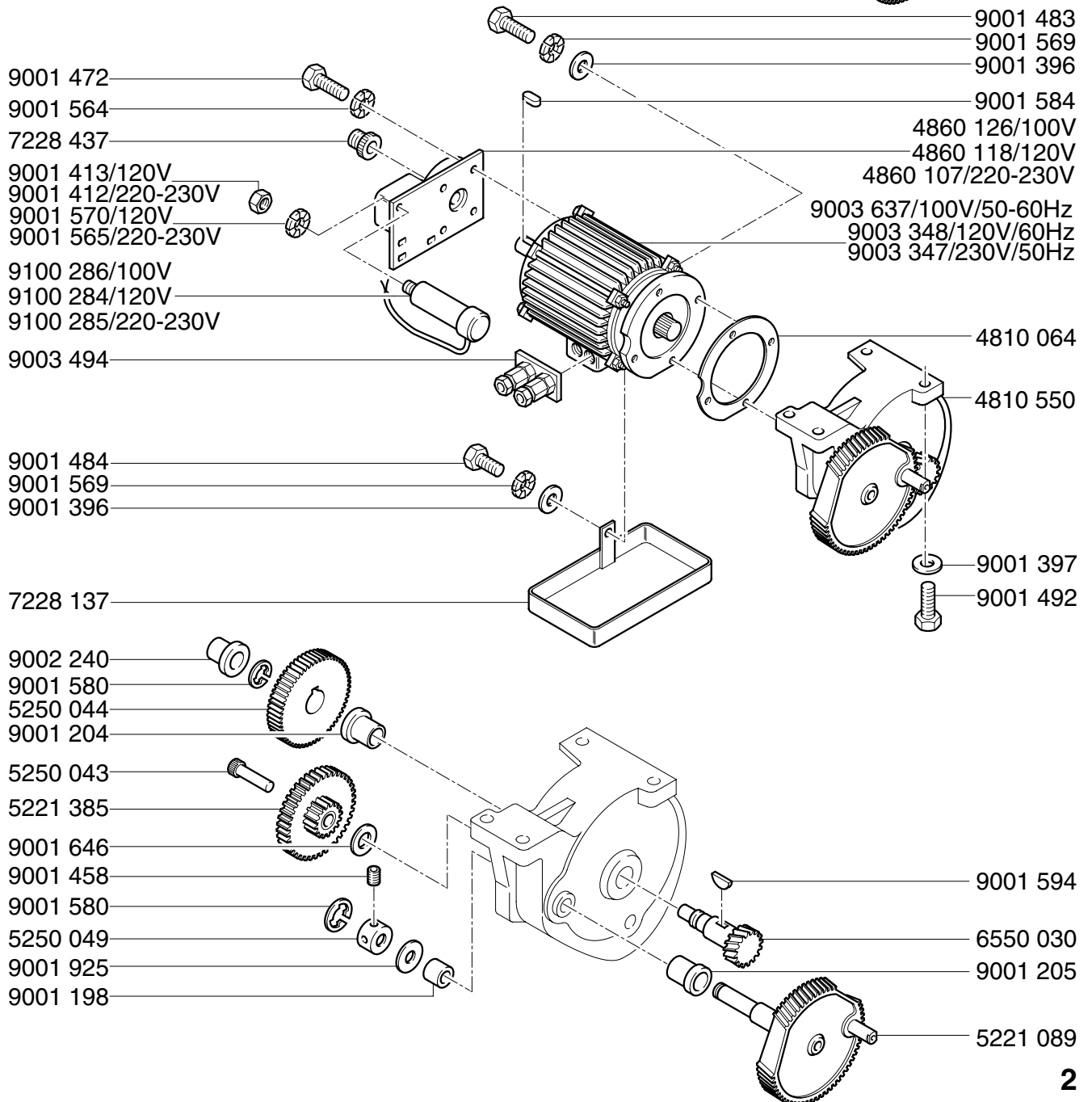
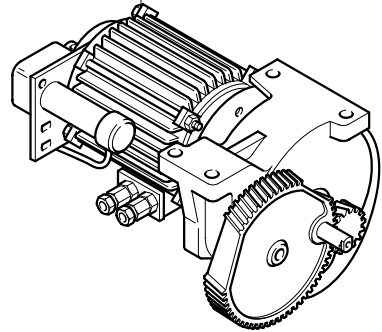

# Mod.4860 ET A

01.07.2012

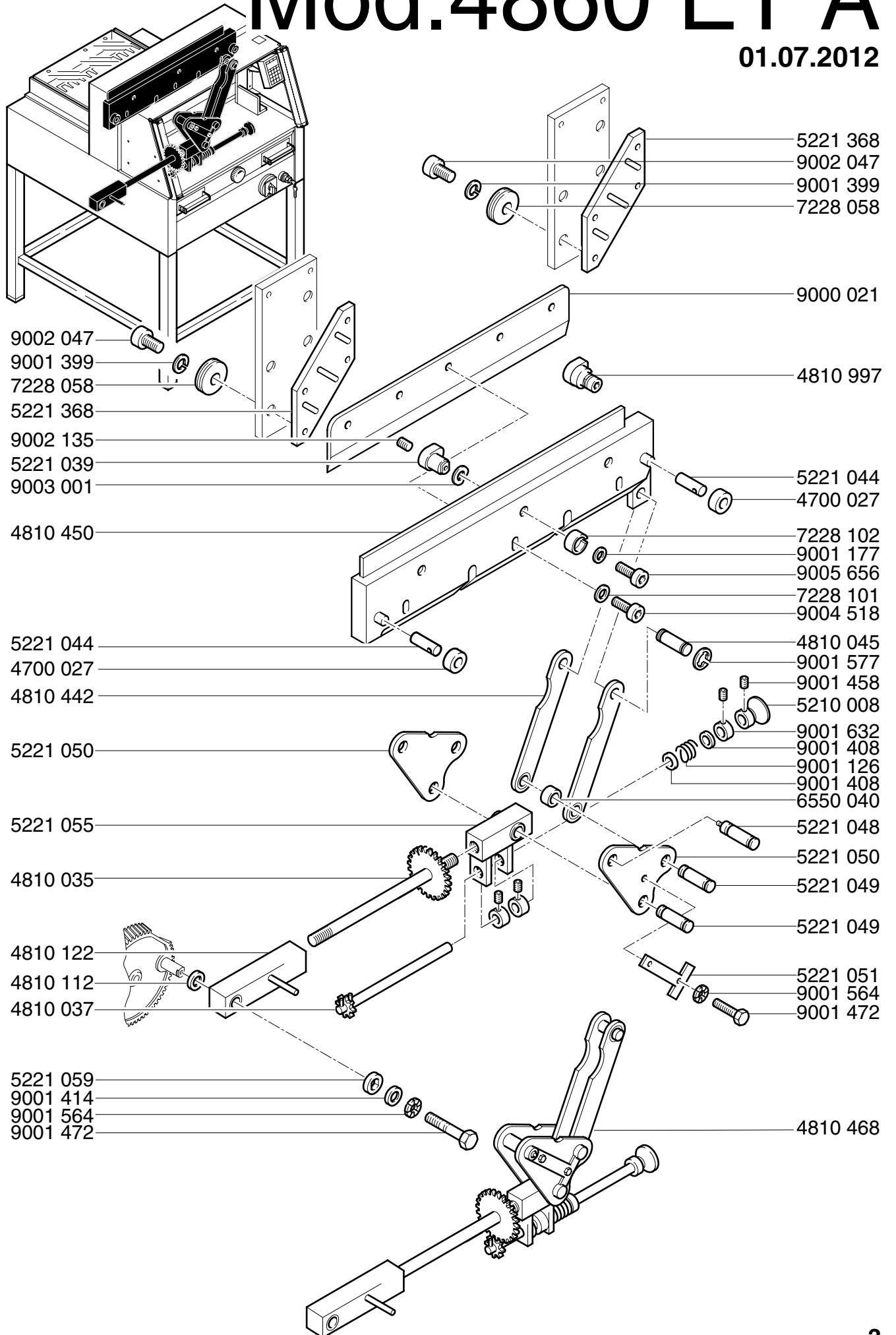

# Mod.4860 ET A

01.07.2012

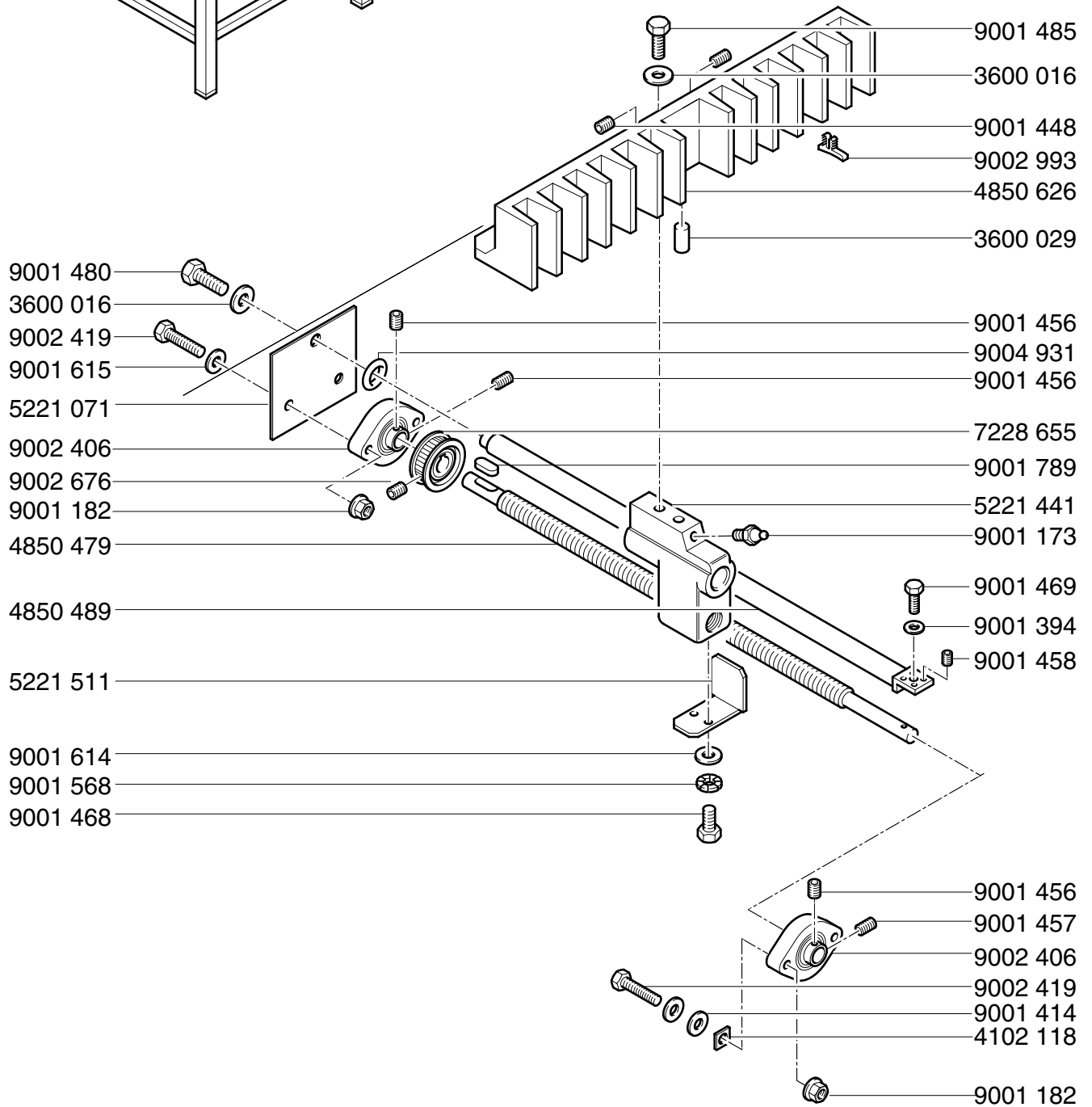
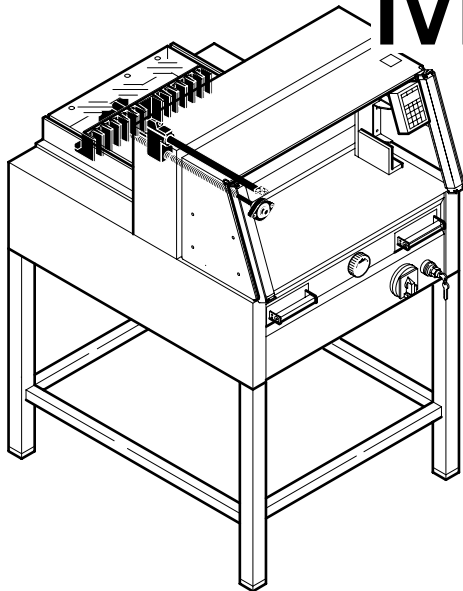

# Mod.4860 ET A

01.07.2012

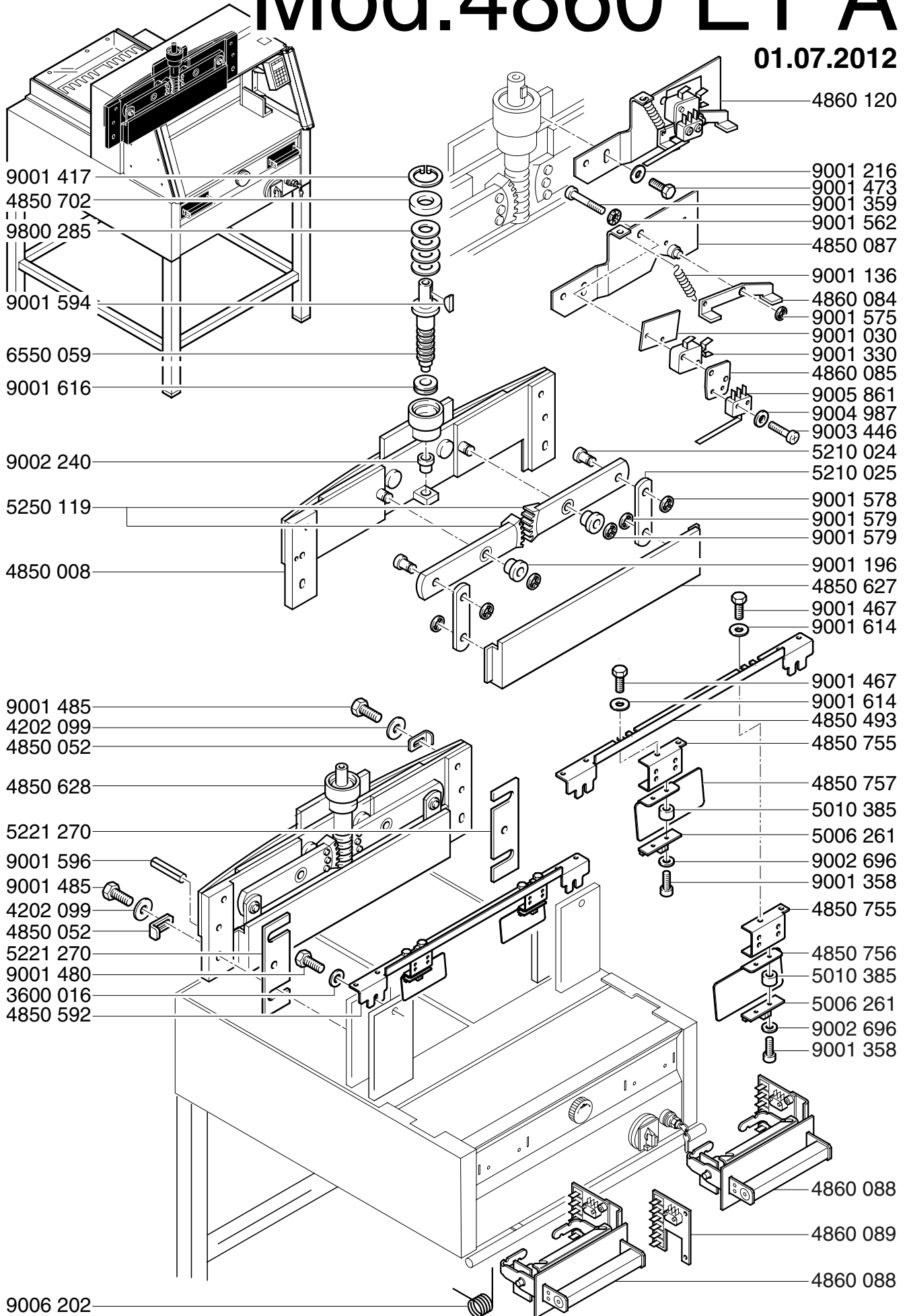

# Mod.4860 ET A

01.07.2012

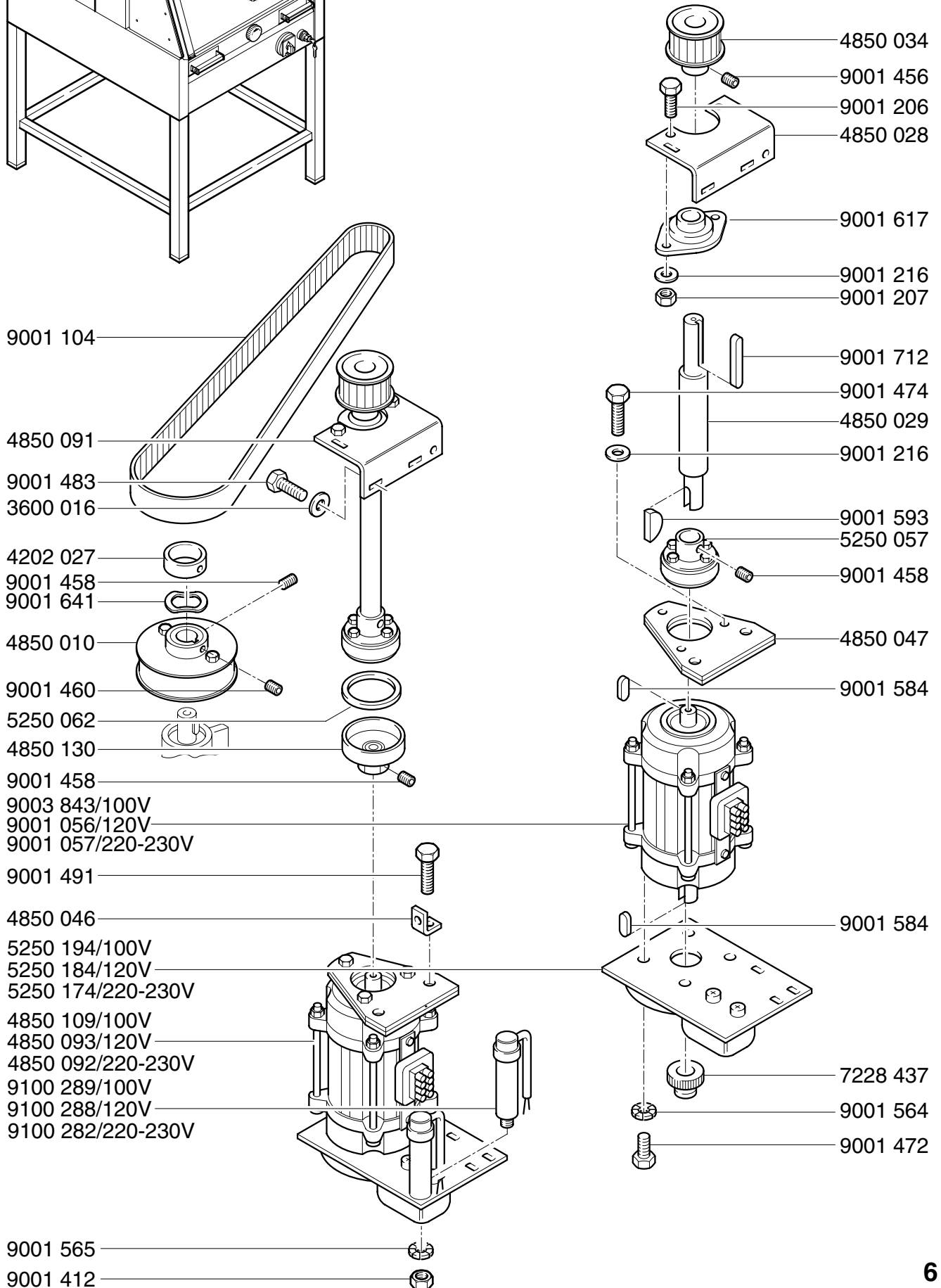
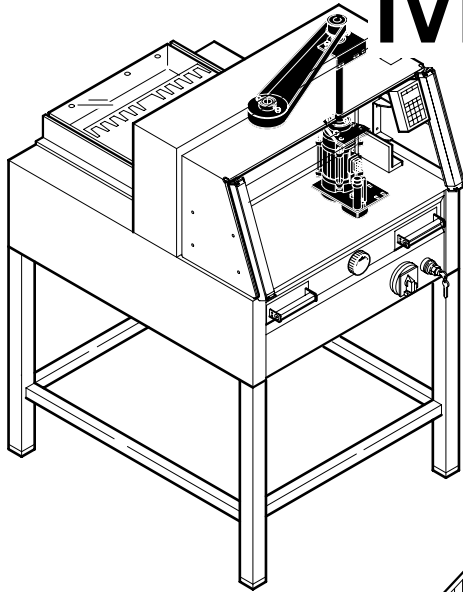

# Mod.4860 ET A

01.07.2012

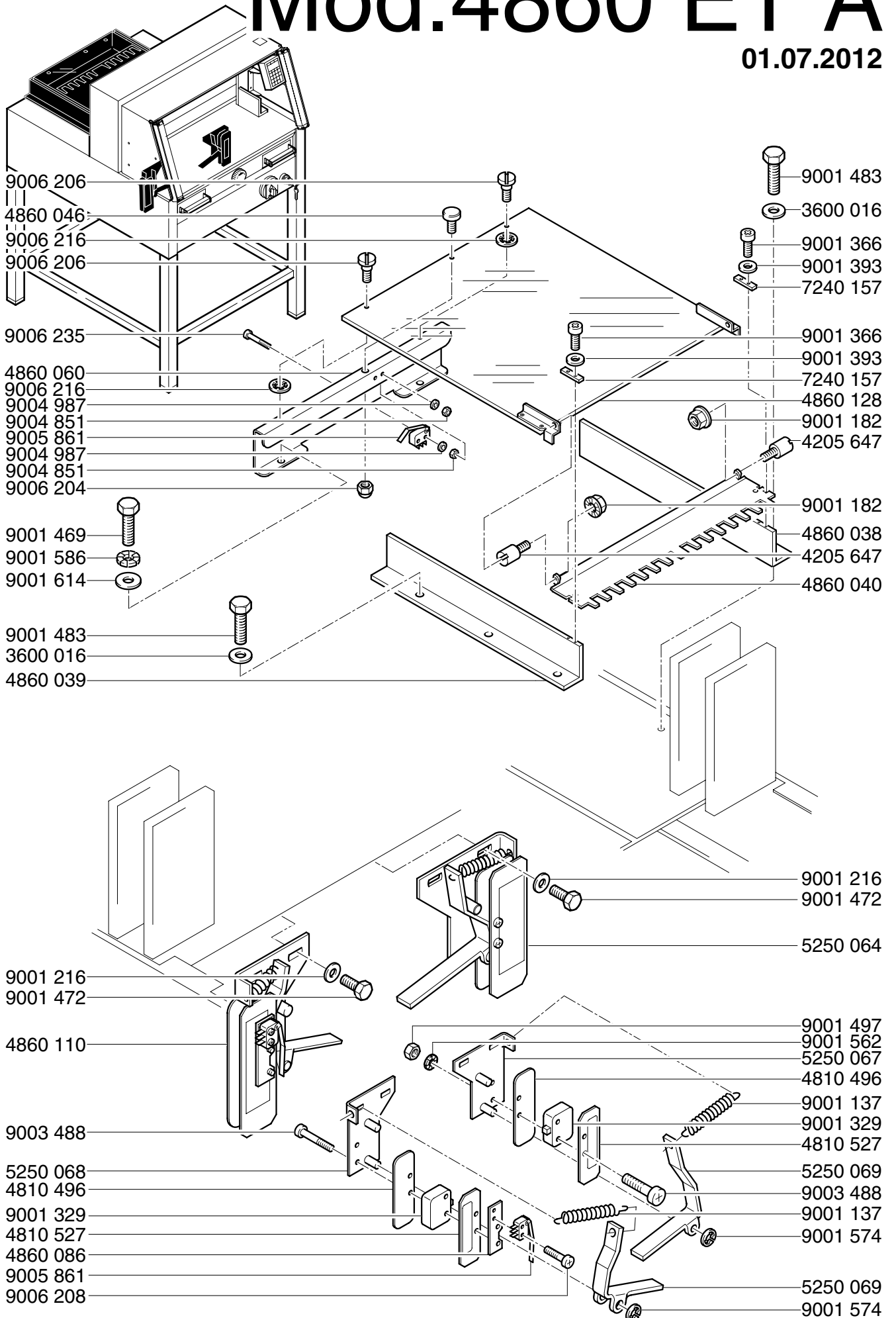

# Mod.4860 ET A

01.07.2012

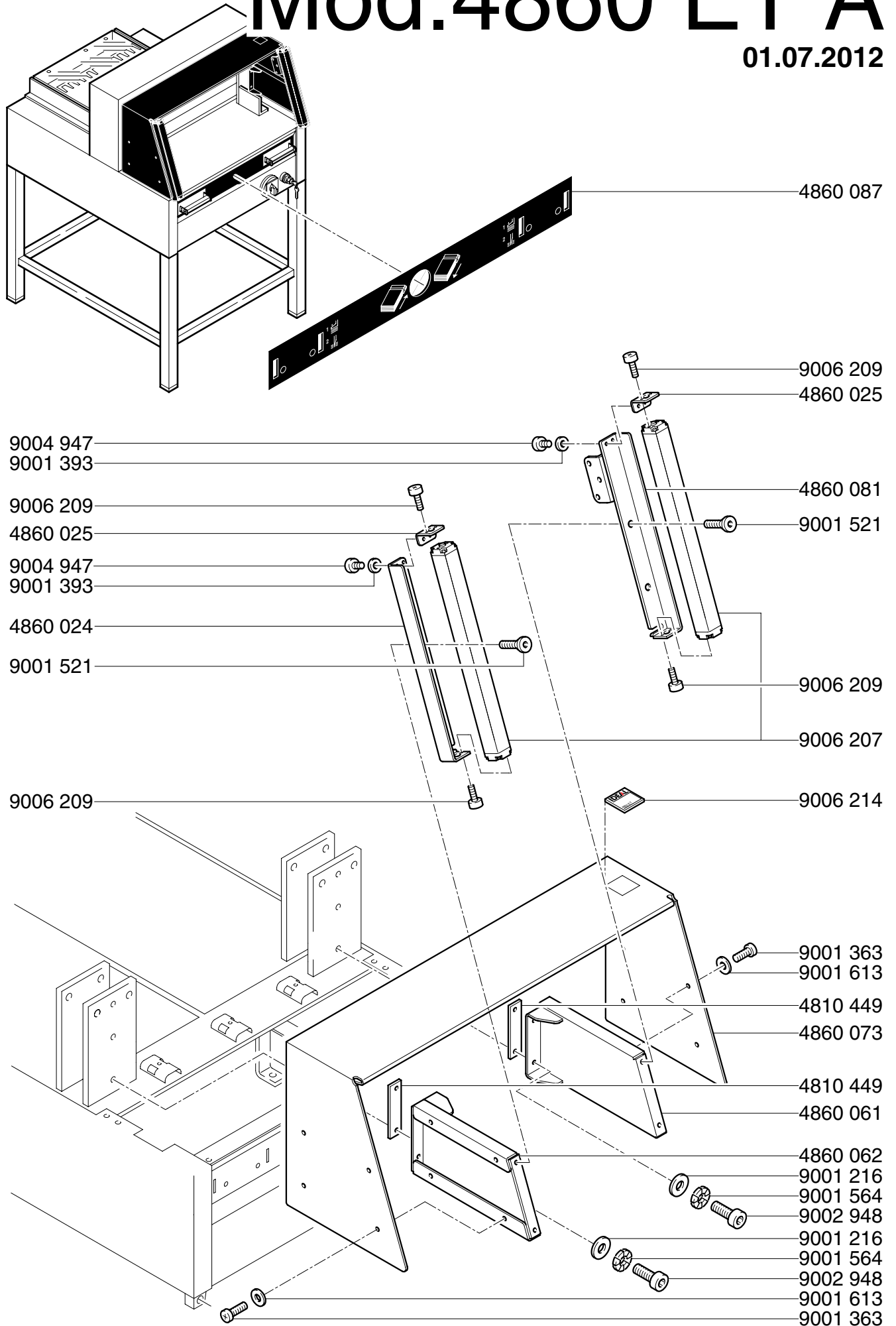



# Mod.4860 ET A

01.07.2012

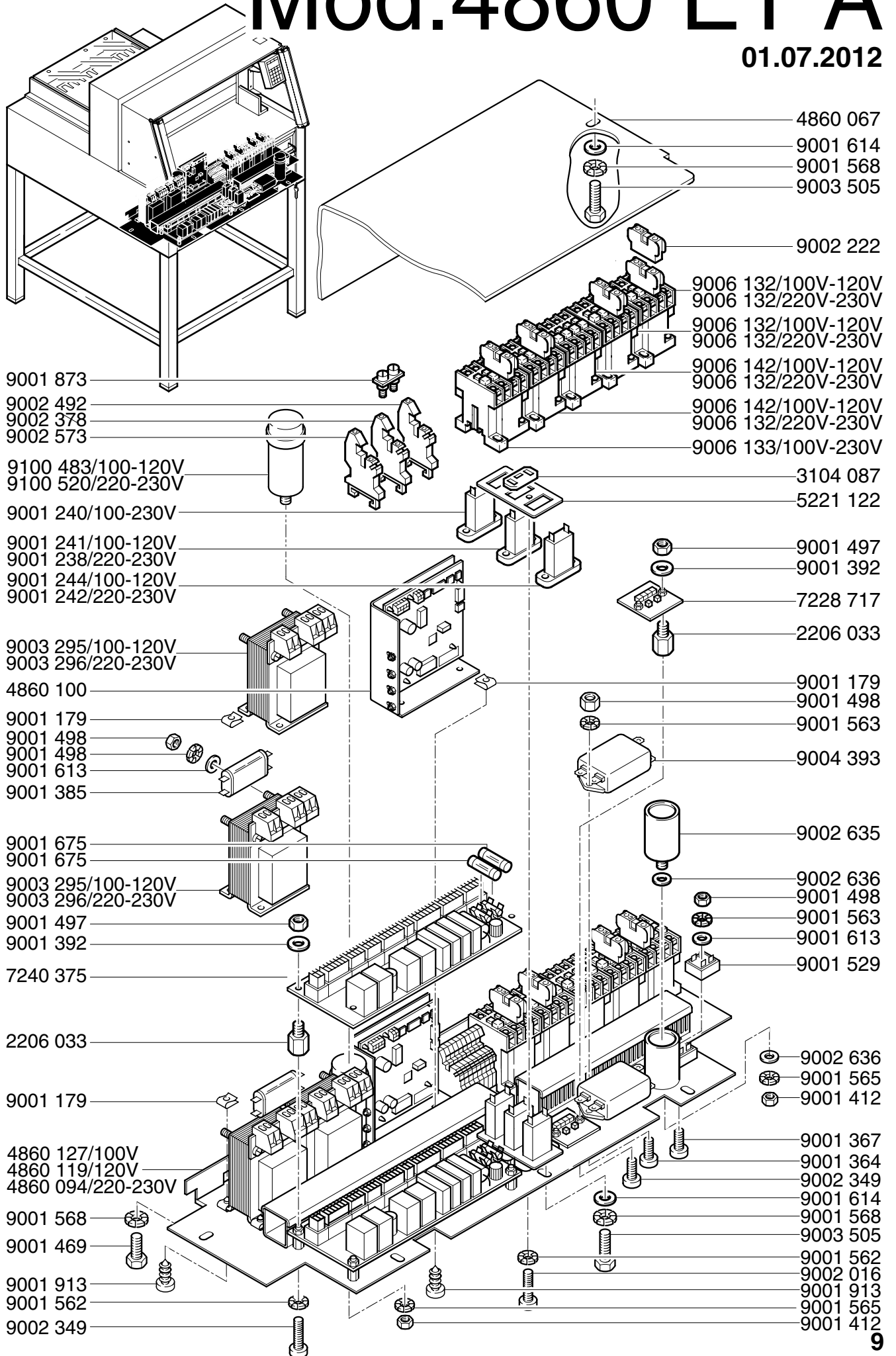

# Mod.4860 ET A

01.07.2012

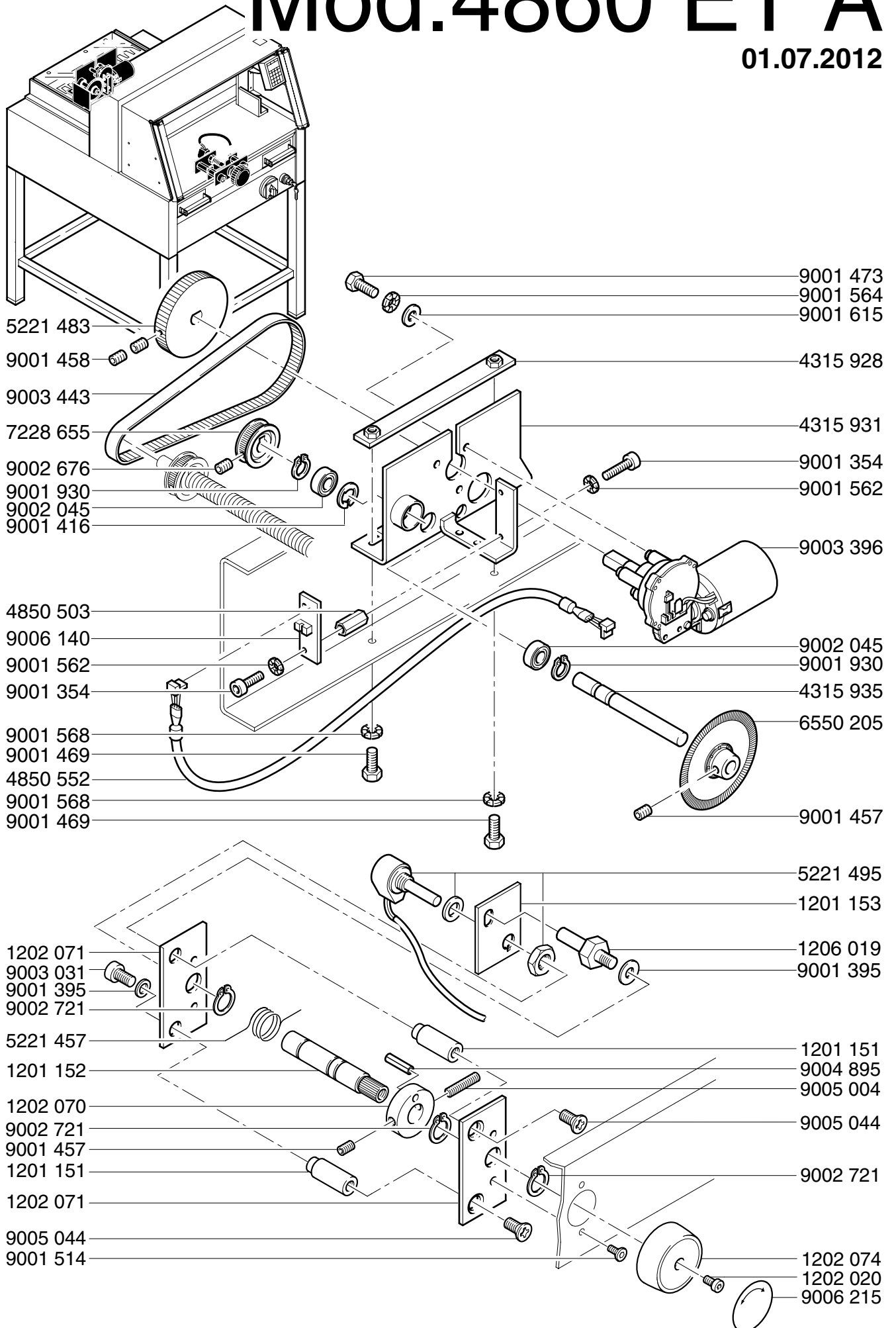

# Mod.4860 ET A

01.07.2012

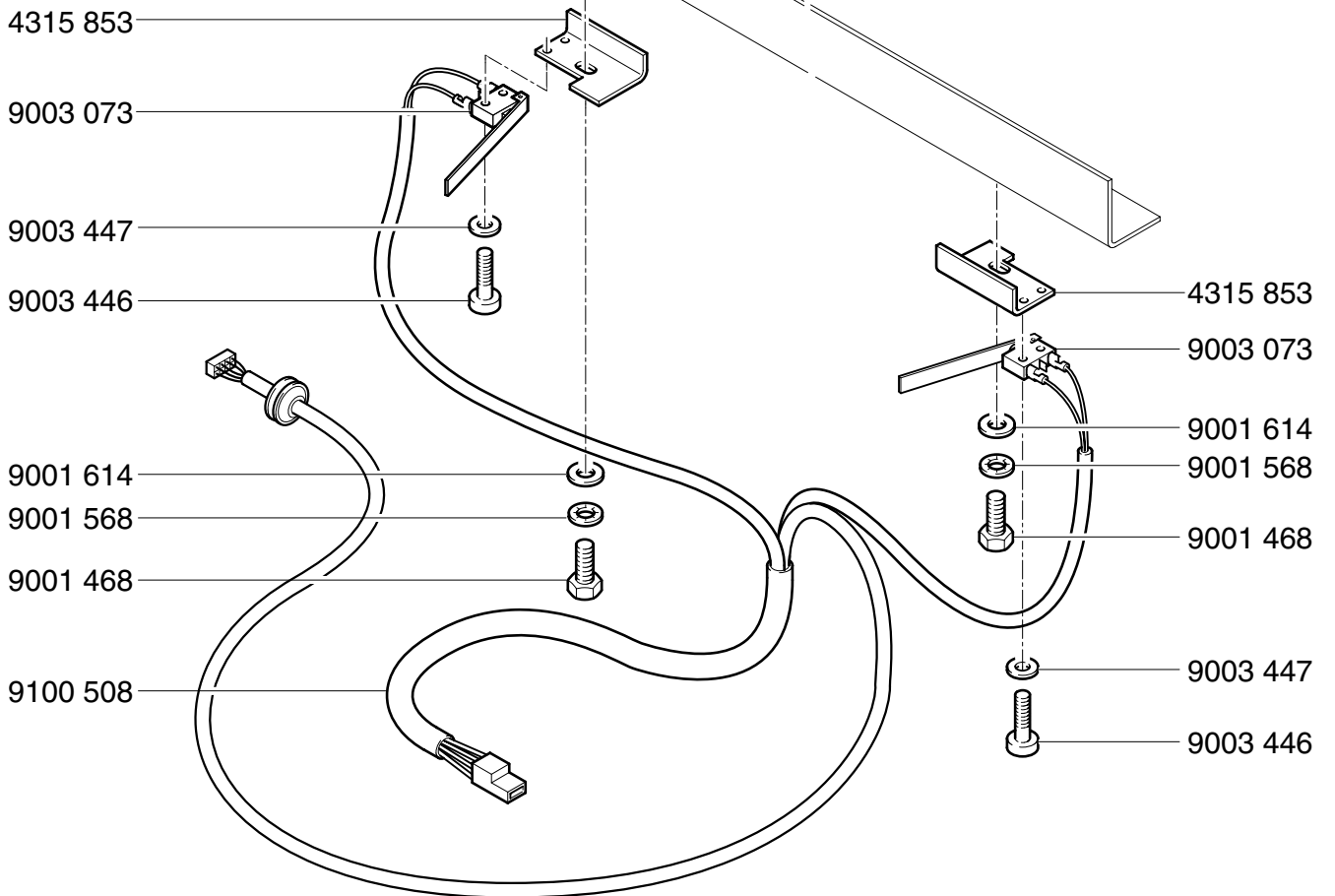
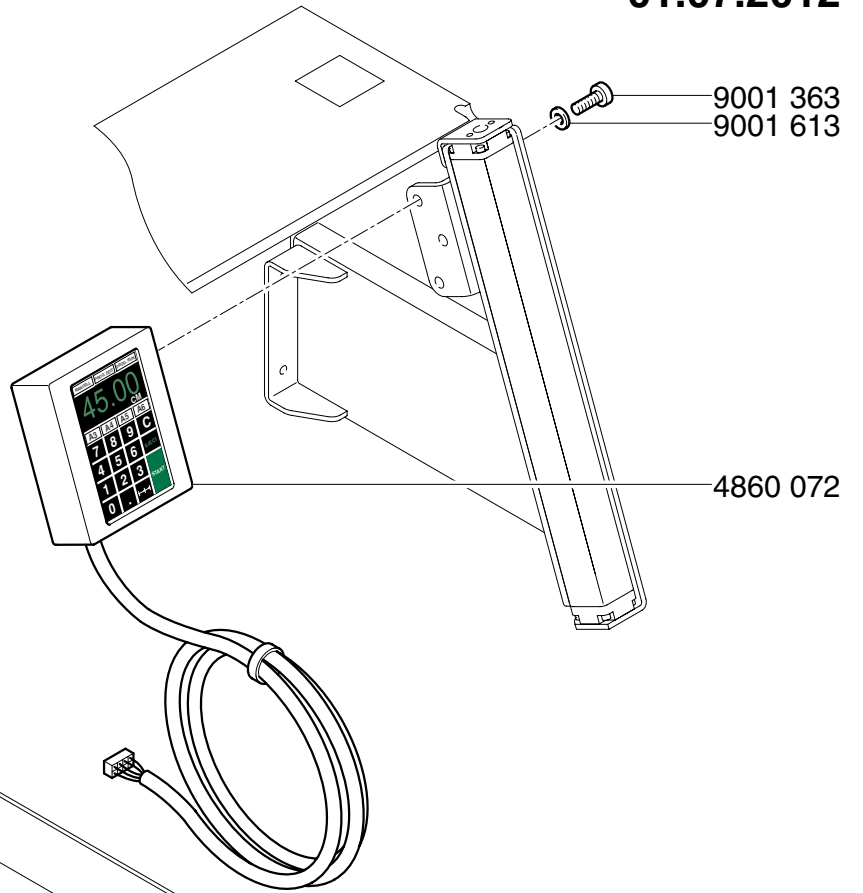
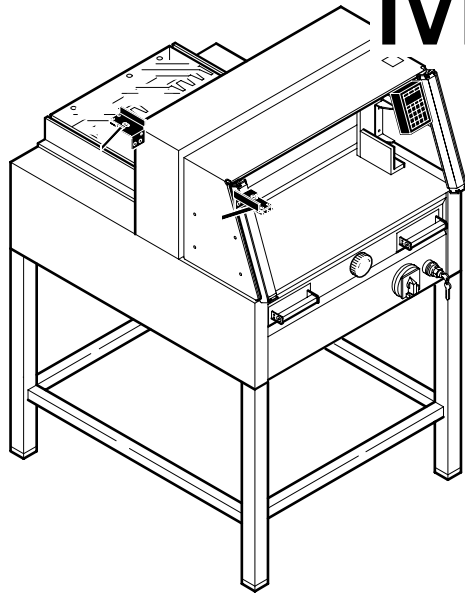

# Mod. 4860 ET A

01.07.2012

4860 095

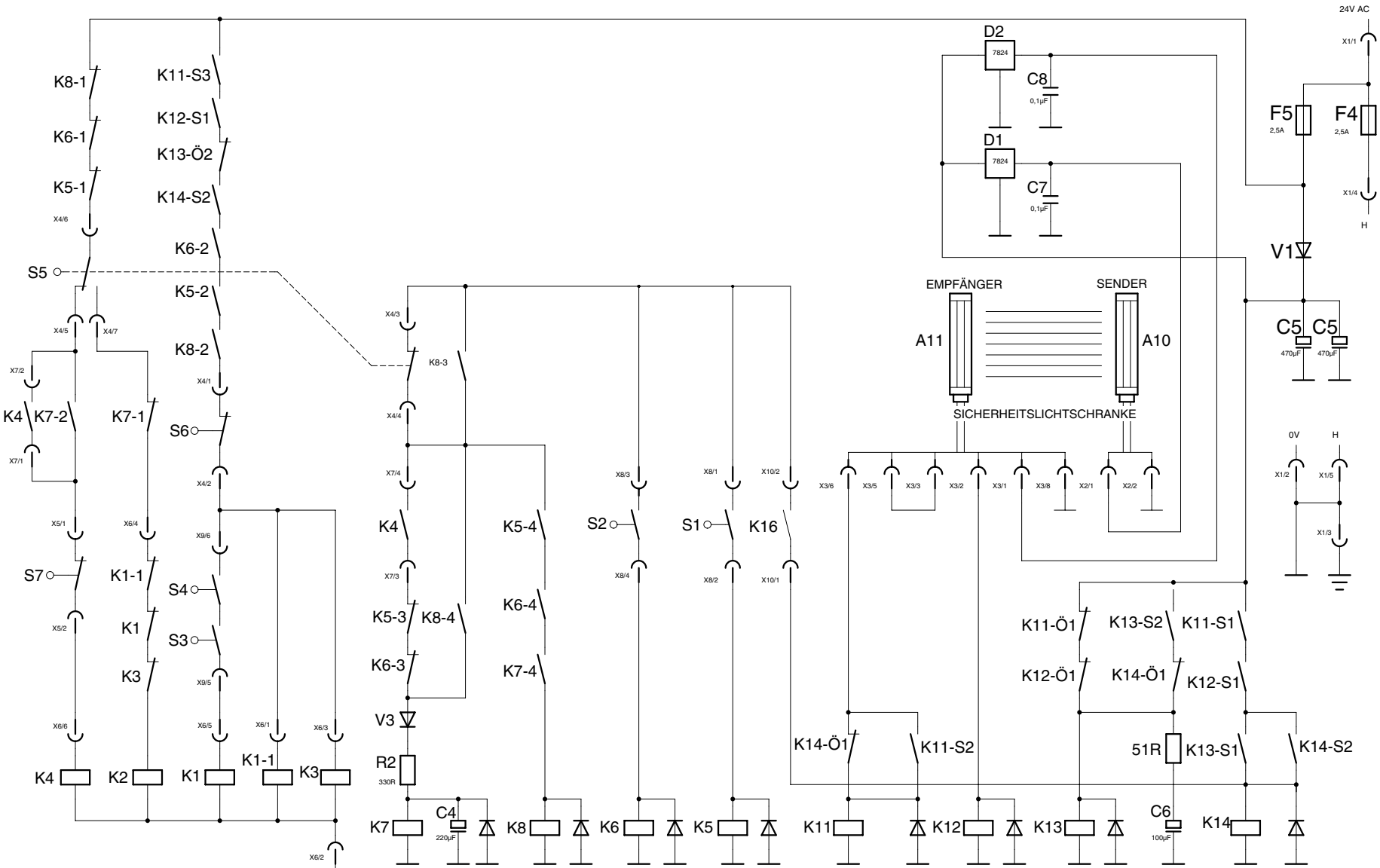

Stromlaufplan 4860 ET A  
schema de  
circuit électrique 4860 ET A  
wiring diagram 4860 ET A

# Mod. 4860 ET A

01.07.2012

Stromlaufplan 4860 ET A  
schema de  
circuit électrique 4860 ET A  
wiring diagram 4860 ET A

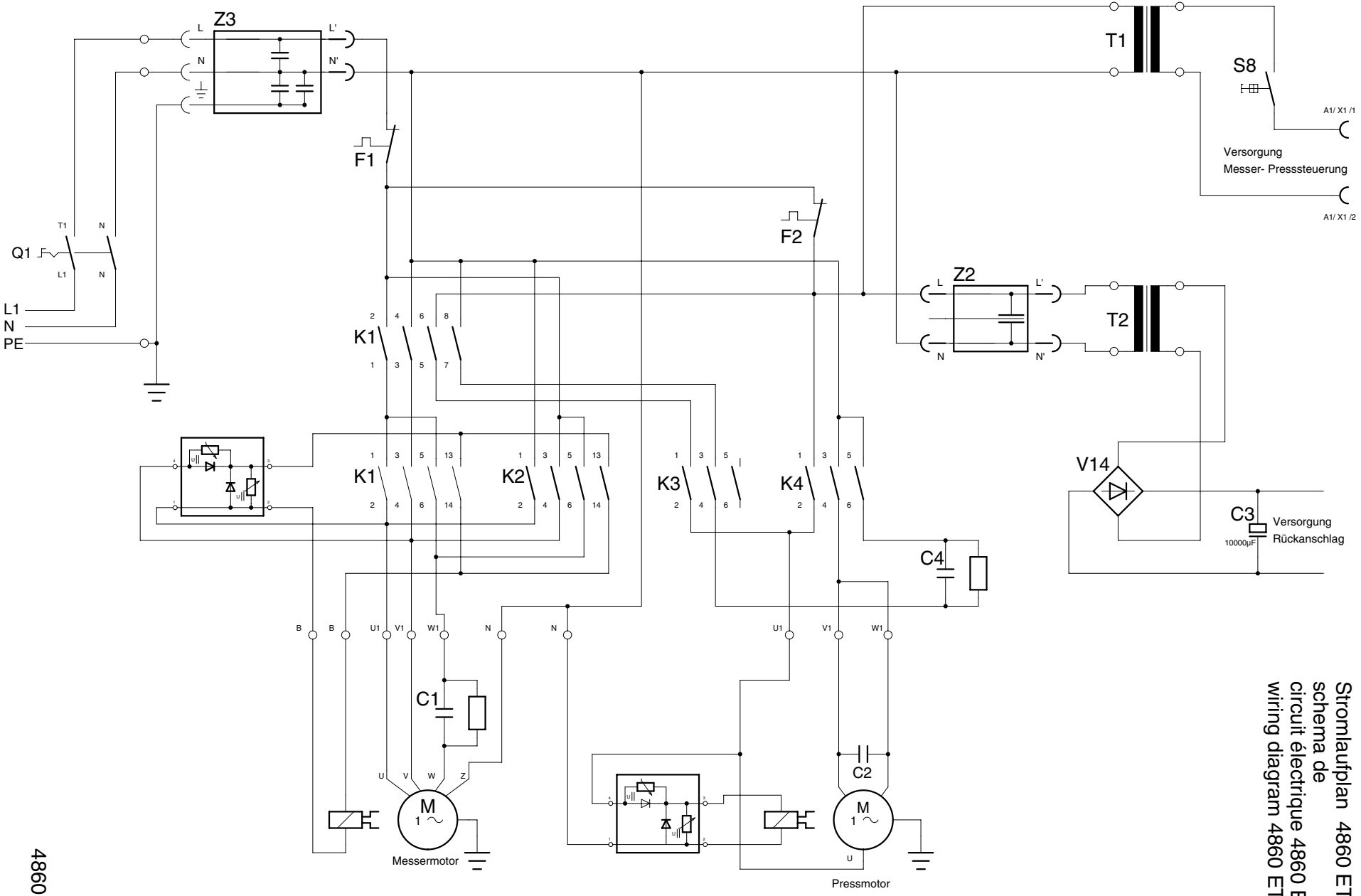

4860 096

13

# Mod.4860 ET A

01.07.2012

Anschlußplan 4860 ET  
Connecting diagram 4860 ET  
Diagramme de branchement 4860 ET

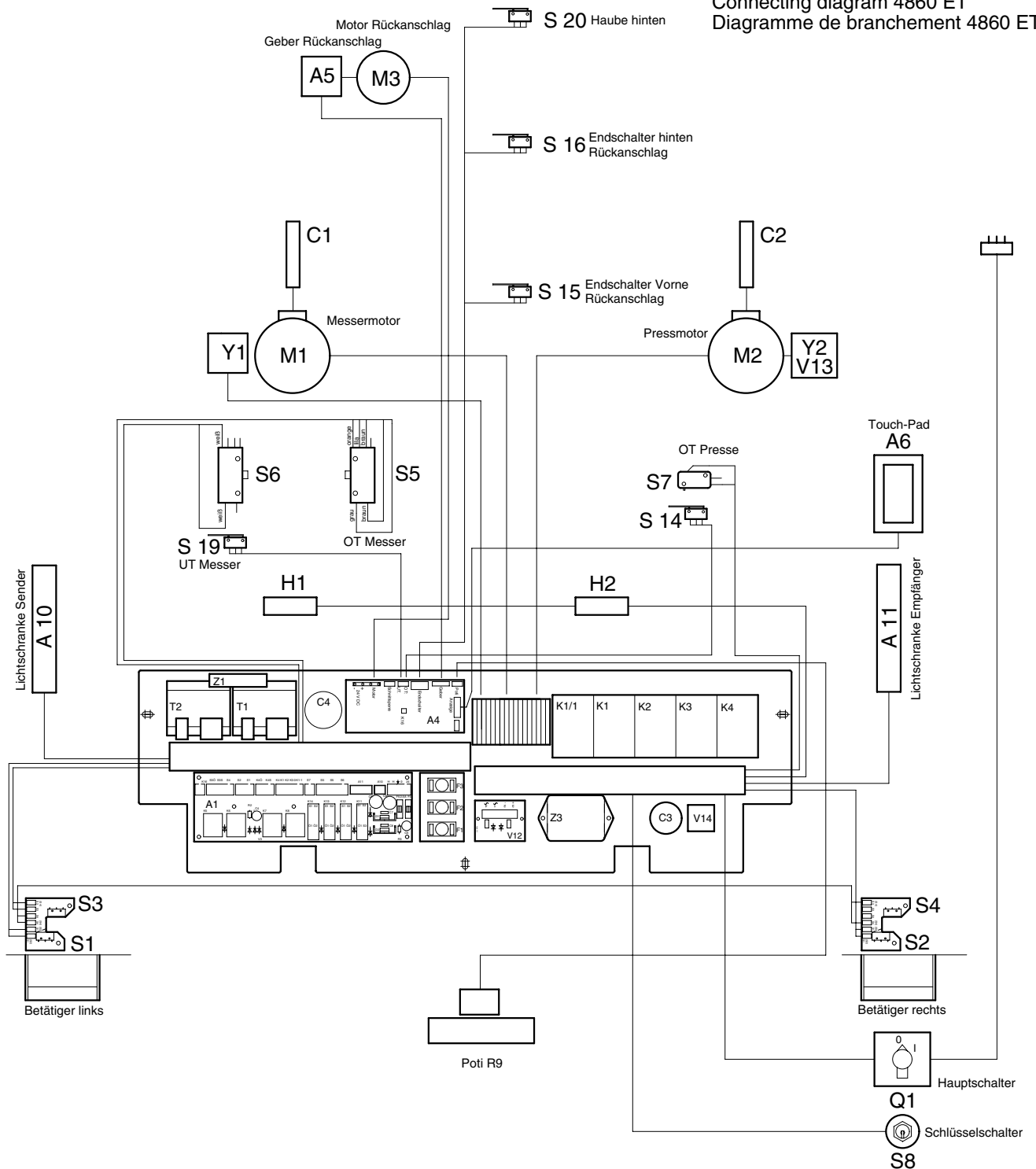

**Farbcode:**

- weiß - blanc - white
- grau - gris - grey
- lila - lilas - purple
- orange - orange - orange
- braun - brun - brown
- ge.-gn.-yel.-gre. - jaune-vert
- blau - blue - blue
- rot - rouge - red
- schwarz - weiß - noir-blanc - black-white
- schwarz - noir - black

4860 097

## Index 4860 ET

Code	Deutsch	English	Francais	Holländisch	Italiano	Seite 1 Español
A1	Platine Steuerung	PCB-control	Platine de commande	Stuurprint	Scheda controllo	Placa de control
A4	Platine Rückanschlag	PCB-backgauge	Platine butée arrière	Zadelmotorsturing	Scheda di battuta posteriore	Placa escuadra trasera
A5	Platine Geber	PCB-counter	Platine compteur d'impulsions	Print teller	Scheda contatore	Control programable
A6	Touch-Pad Programme	Display programming	Commande programmable	Display programmeren	Della programmazione	Placa del contactor
A10	Lichtschranke Sender	Photo cell transmitter	Cellule emettrice	Photocel zender	Fotocellula trasmittente	Transmisor célula fotoeléctrica
A11	Lichtschranke Empfänger	Photo cell receiver	Cellule receptrice	Photocel ontvanger	Fotocellula ricevente	Receptor célula fotoeléctrica
C1	Kondensator Messermotor	Capacitor knife	Condensateur lame	Condensator mes	Condensatore lama	Condensador cuchilla
C2	Kondensator Pressmotor	Capacitor clamp	Condensateur presse	Condensator pers	Condensatore pressino	Condensador prensa
C3	Kondensator Rückanschlag	Capacitor backgauge	Condensateur butée arrière	Condensator achteraanleg	Condensatore posteriore	Condensador escuadra trasera
C4	Kondensator Pressmotor	Capacitor clamp	Condensateur presse	Condensator pers	Condensatore pressino	Condensador prensa
F1	Überlastschutz Messer	Knife overload	Disjoncteur lame	Overbel.schakelaar mesm.	Interruttore sovraccarico lama	Disyuntor estribo cuchilla
F2	Überlastschutz Presse	Clamp overload	Disjoncteur presse	Overbel.schakelaar persm.	Interr. sovraccarico pressino	Disyuntor estribo prensa
F3	Überlastschutz Rückans.	Backgauge overload	Disjoncteur butée arrière	O. schakelaar achteraanleg	Interr. sovr. di buttata posteriore	Disyuntor escuadra trasera
F4	Sicherung	Fuse	Fusible	Zekering	Fusibile	Fusible
F5	Sicherung	Fuse	Fusible	Zekering	Fusibile	Fusible
H1	Schnittandeuter	Cutting line light	Ampoule ligne de coupe	Snijlijnverlichting	Indicatore taglio	Luz lá«ea de corte
H2	Schnittandeuter	Cutting line light	Ampoule ligne de coupe	Snijlijnverlichting	Indicatore taglio	Luz lá«ea de corte
K1/	Schütz Messer ab	Knife-down contactor	Contacteur descente de lame	Relais mes omlaag	Interr. autom. discesa lama	Contactor bajada cuchilla
K1/1	Schütz Messer ab	Knife-down contactor	Contacteur descente de lame	Relais mes omlaag	Interr. autom. discesa lama	Contactor bajada cuchilla
K2	Schütz Messer auf	Knife-up contactor	Contacteur remontée de lame	Relais mes omhoog	Interr. autom. risalita lama	Contactor subida cuchilla
K3	Schütz Presse ab	Clamp-down contactor	Contacteur descente presse	Relais pers omlaag	Interr. autom. discesa pressino	Contactor bajada prensa
K4	Schütz Presse auf	Clamp-up contactor	Contacteur remontée presse	Relais pers omhoog	Interr. autom. risalita pressino	Contactor subida prensa
K5	Relais Taster links	Relay push button left	Relais touche gauche	Relais drukknop links	Relais pulsante sinistro	Rel Ebotón izquierdo
K6	Relais Taster rechts	Relay push button right	Relais touche droite	Relais drukknop rechts	Relais pulsante destro	Rel Ebotón derecho
K7	Relais Verzögerung	Time-delay relay	Relais retard	Vertragsrelais	Relais di ritardo	Relè de atraso
K8	Relais	Relay	Relais	Relais	Relais	Relè
K11	Sicherheitsrelais	Relay safety	Relais sécurit	Veiligheidsrelais	Relais sicurezza	Relè seguridad
K12	Sicherheitsrelais	Relay safety	Relais sécurit	Veiligheidsrelais	Relais sicurezza	Relè seguridad
K13	Sicherheitsrelais	Relay safety	Relais sécurit	Veiligheidsrelais	Relais sicurezza	Relè seguridad
K14	Sicherheitsrelais	Relay safety	Relais sécurit	Veiligheidsrelais	Relais sicurezza	Relè seguridad
K16	Relais Schnittsperre	Relay knife limit	Relais interdiction de coupe	Relais Snij blokkering	Relais taglio fermo	Relè cierre de corte

## Index 4860 ET

Seite 2

Code	Deutsch	English	Francais	Holländisch	Italiano	Espanol
						Motor de corte
M1	Antriebsmotor Messer	Cutting motor	Moteur lame	Snijmotor	Motore lama	Motor prensa
M2	Antriebsmotor Presse	Clamp motor	Moteur presse	Persbalkmotor	Motore pressino	Motor escuadra trasera
M3	Motor Rückanschlag	Backgauge motor	Moteur butée arrière	Motor achteraanleg	Motore di battuta posteriore	Interruptor principal
Q1	Hauptschalter	Main switch	Interrupteur principal	Hoofdschakelaar	Interruttore principale	Poti escuadra trasera
R9	Poti Rückanschlag	Poti back gauge	Poti butée arrière	Poti achteraanleg	Poti di buttata posteriore	Elementos de mando prensa
S1	Bedienelement Presse	Actuator clamp	Commande bi manuelle presse	Hantels pers	Attuatori pressino	Elementos de mando prensa
S2	Bedienelement Presse	Actuator clamp	Commande bi manuelle presse	Hantels mes + pers	Attuatori lama + pressino	Elementos de mando cuchilla
S3/S4	Bedienelement Messer	Actuator knife	Commande bi manuelle lame	Hantels pers	Attuatori pressino	Interruptor subida cuchilla
S5	OT-Stopschalter Messer	Switch knife top	Arrêt lame haut	Schakelaar mes boven	Fermo lama alto	Interruptor bajada cuchilla
S6	UT-Stopschalter Messer	Switch knife bottom	Arrêt lame bas	Schakelaar mes beneden	Fermo lama basso	Interruptor subida prensa
S7	OT-Stopschalter Presse	Switch clamp on top	Arrêt presse Haut	Schakelaar persbalk boven	Fermo pressino alto	Llave interruptor
S8	Schalterschloß	Key switch	Contacteur á clé	Sleutelschakelaar	Interruttore a chiave	Interruptor prensa/escuadra trasera
S14	OT Presse/ Rückanschlag	Switch clamp/backgauge top	Arrêt presse/butée haut	Schakelaar persbalk/achteraanleg	Fermo pressino/battuta posteriore	Interruptor escuadra trasera frente
S15	Endschalter Rückanschlag vo	Switch backgauge front	Arrêt butée avant	Schakelaar achteraanleg front	Fermo battuta posteriore anteriore	Interruptor escuadra trasera atras
S16	Endschalter Rückanschlag hi	Switch backgauge behind	Arrêt butée avant derrière	Schakelaar achteraanleg achter	Fermo battuta posteriore dietro	Interruptor cuchilla/escuadra trasera
S19	UT Messer /Rückanschlag	Switch clamp/backgauge	Arrêt lame/butée bas	Schakelaar mes/achteraanleg	Fermo lama/battuta posteriore	Interruptor cubierta atrás
S20	Schalter Haube hinten	Switch cover behind	Arrêt capot derrière	Schakelaar kap achter	Fermo cappuccio dietro	Transformador
T1	Transformator	Transformer	Transformateur	Transformator	Transformatore	Transformador
T2	Transformator	Transformer	Transformateur	Transformator	Transformatore	Rectificador
V12	Gleichrichter Bremse	Rectifier	Redresseur frein	Gelijkrichter rem	Raddrizzatore freno	Rectificador
V13	Gleichrichter Bremse	Rectifier	Redresseur frein	Gelijkrichter rem	Raddrizzatore pressino	Rectificador escuadra trasera
V14	Gleichrichter Rückanschlag	Rectifier backgauge	Redresseur butée arriere	Gelijkrichter achteraanleg	Reddrizzatore di battuta posteriore	Freno motor cuchilla
Y1	Bremse Messermotor	Brake, knife motor	Frein moteur de lame	Rem snijmotor	Freno motore lama	Freno motor prensa
Y2	Bremse Pressmotor	Brake, clamp motor	Frein moteur de presse	Rem persmotor	Freno motore pressino	Válvula reguladora
Z1	Drossel	Throttle	Self	Ontstoorspoel	Valvola di regolazione	Válvula reguladora
Z3	Drossel	Throttle	Self	Ontstoorspoel	Valvola di regolazione	e

Mod. 4860 ET A

01.07.2012



# Mod.4860 ET A

01.07.2012

