

Mod. 5222 DIGICUT B

01.01.2011

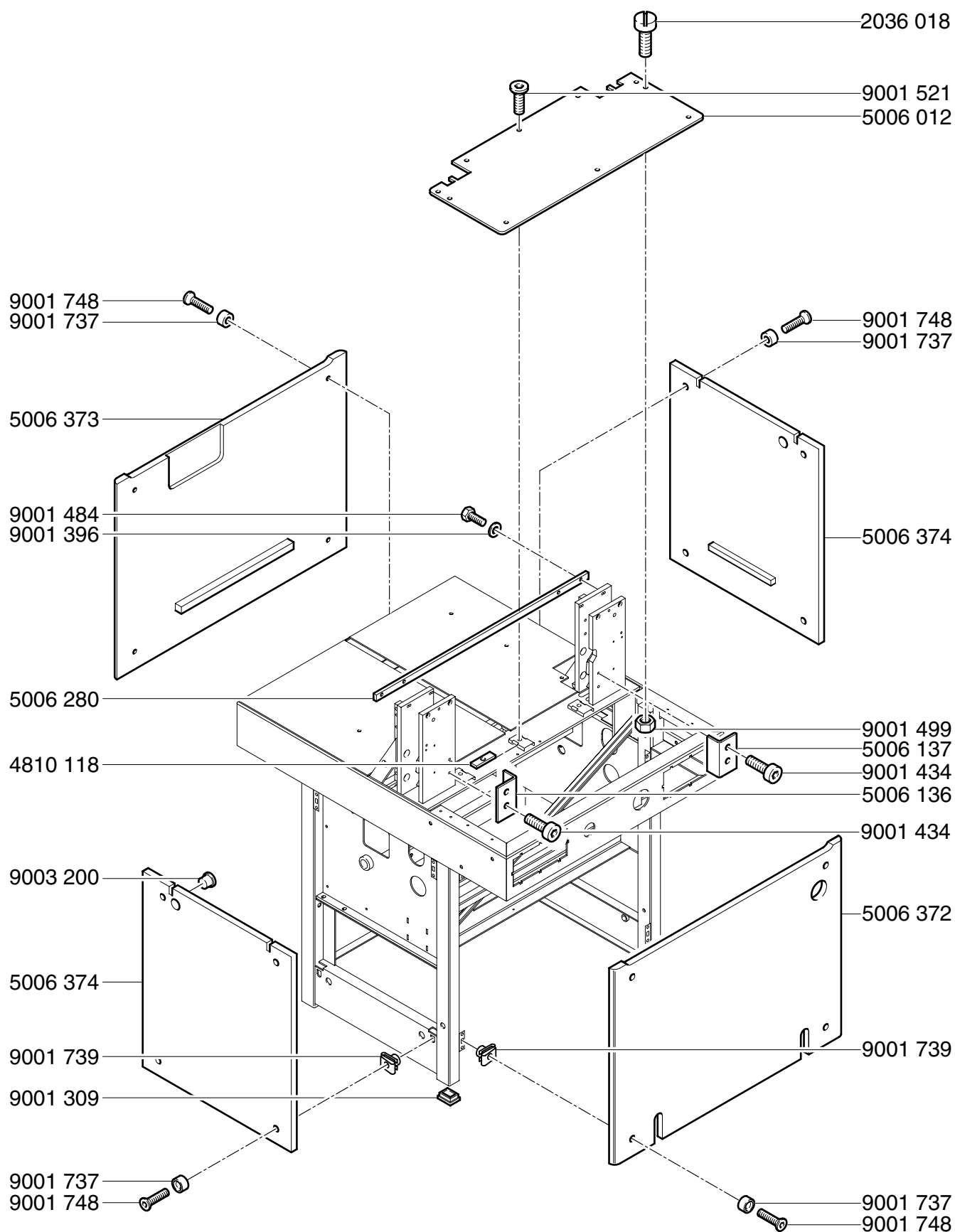

Mod. 5222 DIGICUT B

01.01.2011

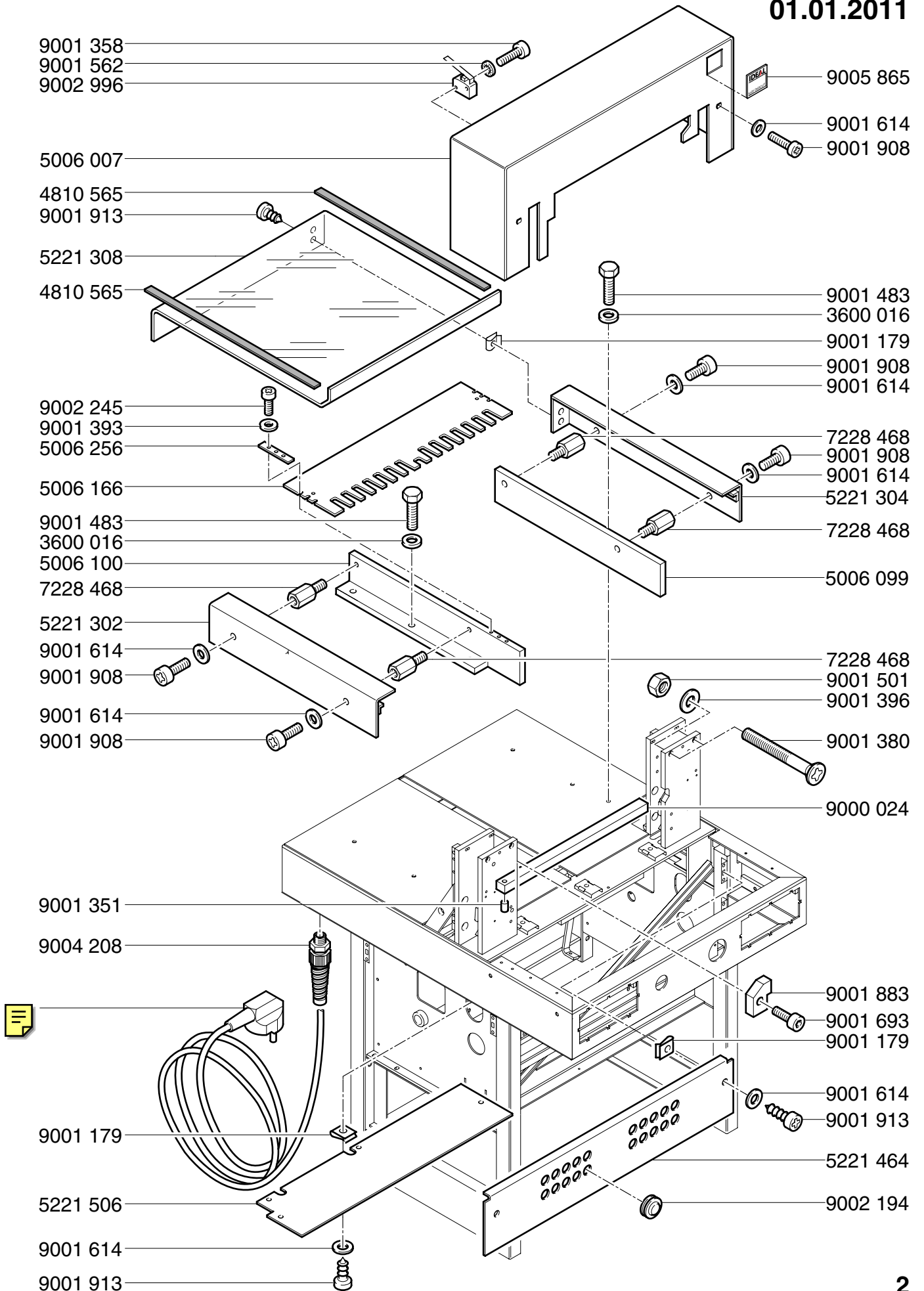

Mod. 5222 DIGICUT B

01.01.2011

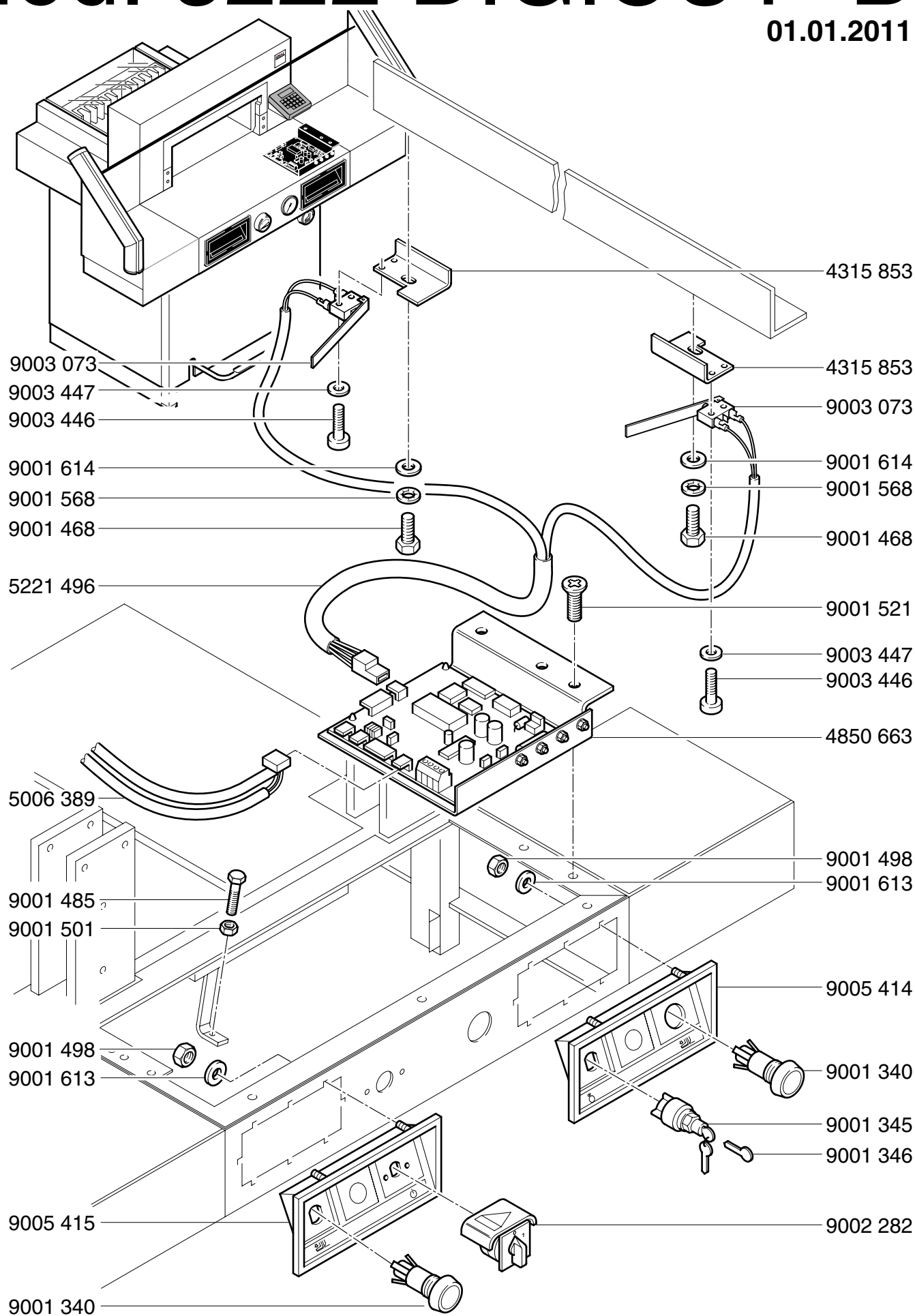

Mod. 5222 DIGICUT B

01.01.2011

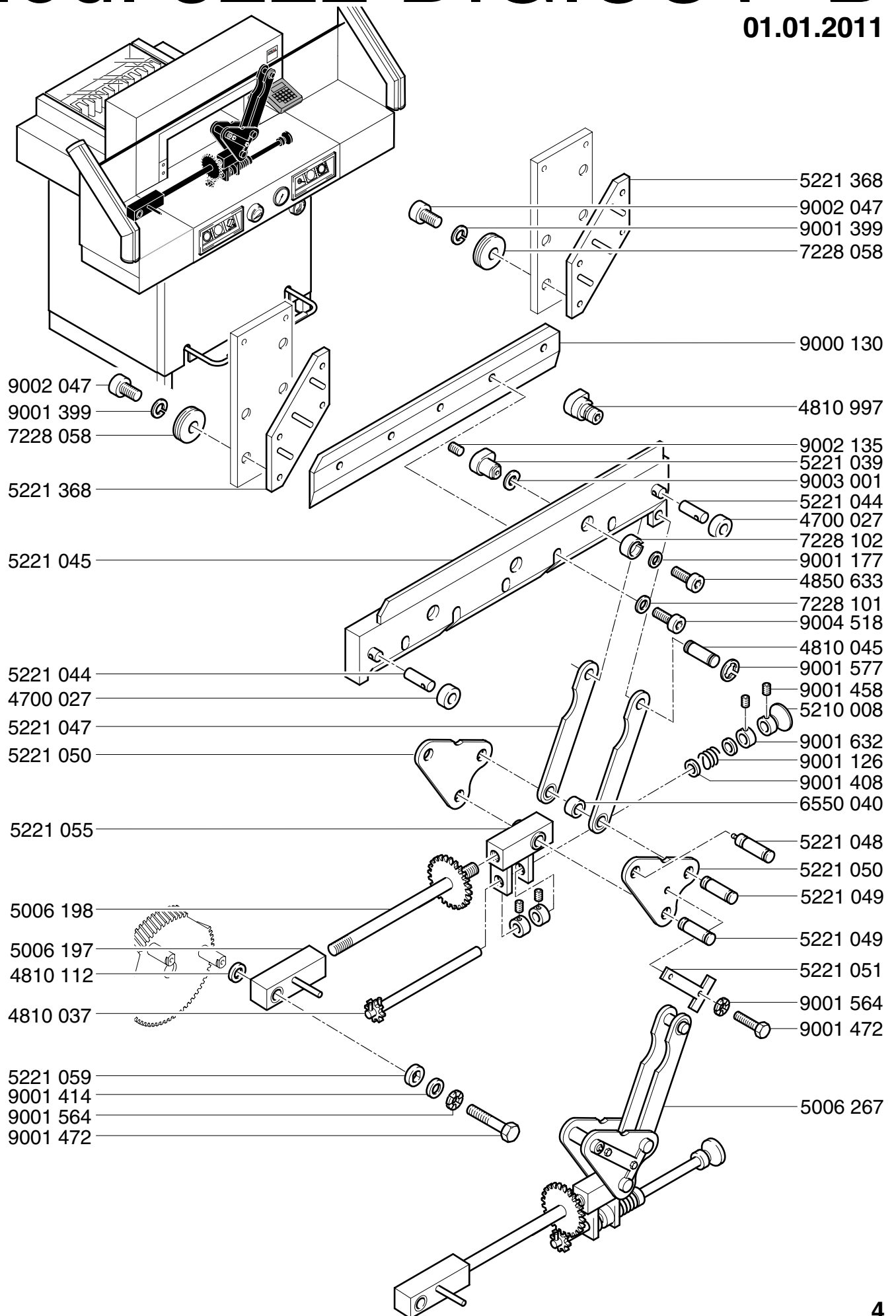

Mod. 5222 DIGICUT B

01.01.2011

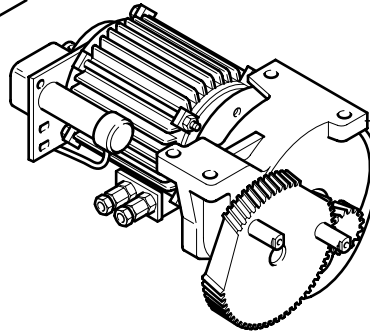
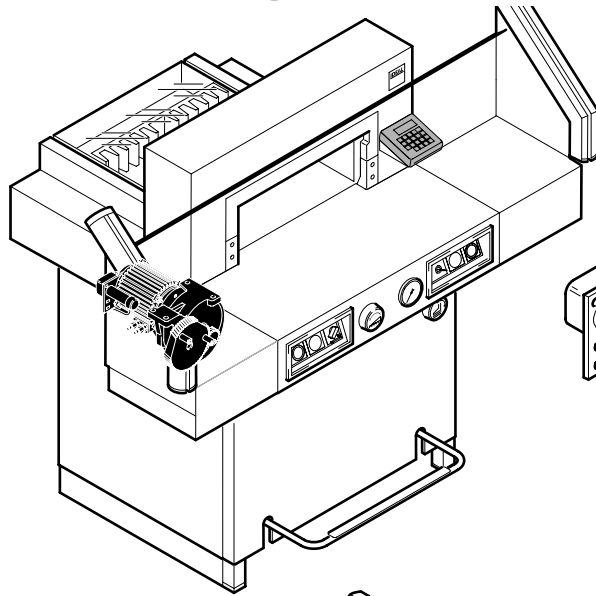

5006 304/115V/60Hz
5006 260/220-230V/50Hz

9001 472
9001 564
7228 437
9001 413/115V
9001 412/220-240V
9001 570/115V
9001 565/220-240V

9001 483
9001 569
9001 396
9001 584

7240 229/230V
7240 411/120V

9100 284/115V
9100 379/220-240V

9005 423/115V/60Hz
9005 416/220-230V/50Hz

9003 494
9001 480
9001 569
9001 396

4810 064

5006 265

5006 290

9001 396
9001 569
9001 480

9001 397

9001 492

5006 273

9002 240

9001 580

5006 163

9001 204

5250 043

5006 160

9001 646

9001 458

9001 580

5250 049

9001 925

9001 198

9001 614

9001 568

9001 468

5250 036

9001 594

6550 030

9001 205

5006 200

Mod. 5222 DIGICUT B

01.01.2011

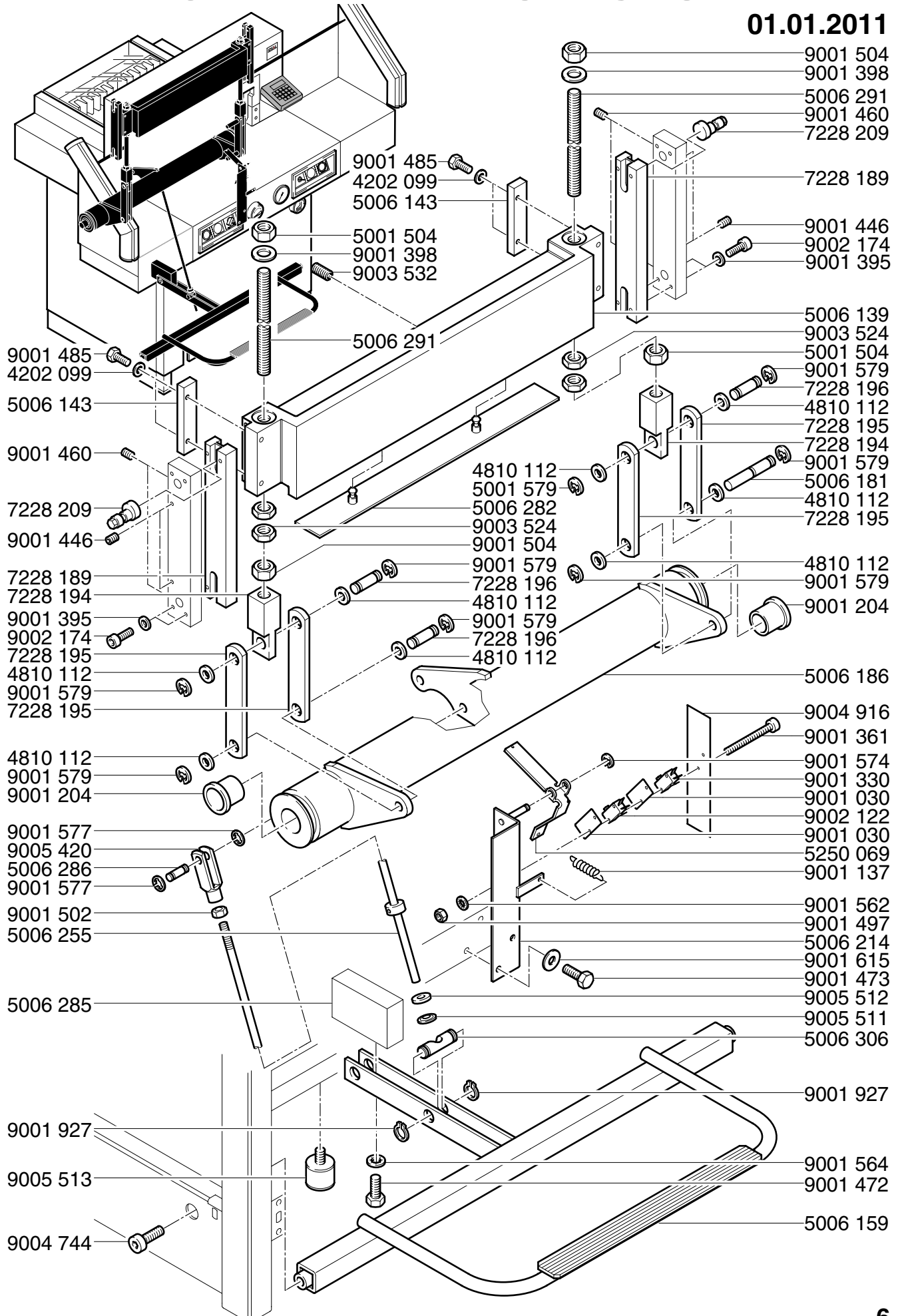

Mod. 5222 DIGICUT B

01.01.2011

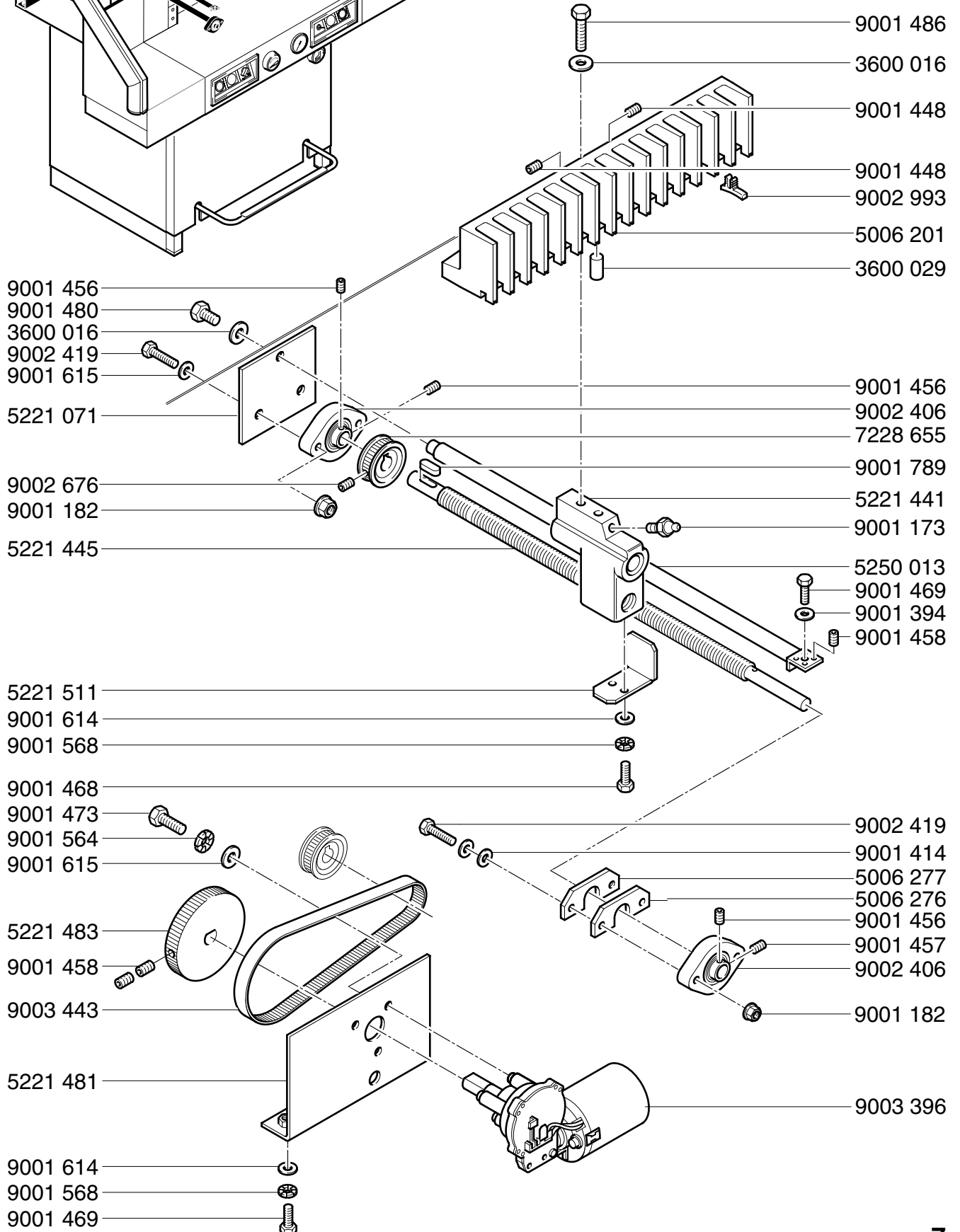
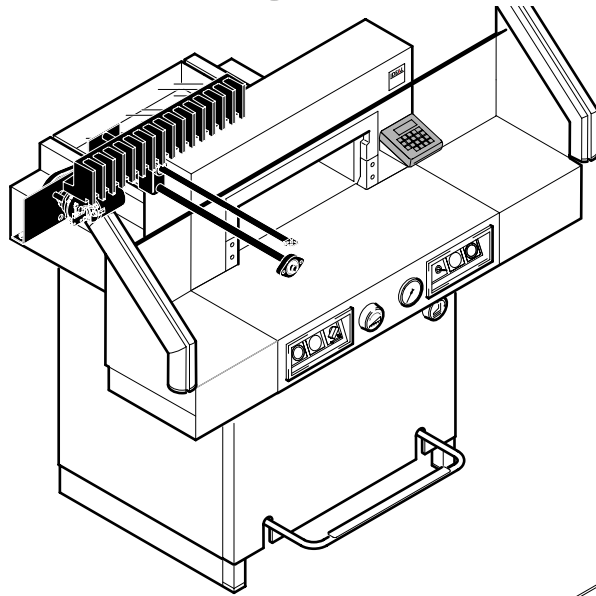

Mod. 5222 DIGICUT B

01.01.2011

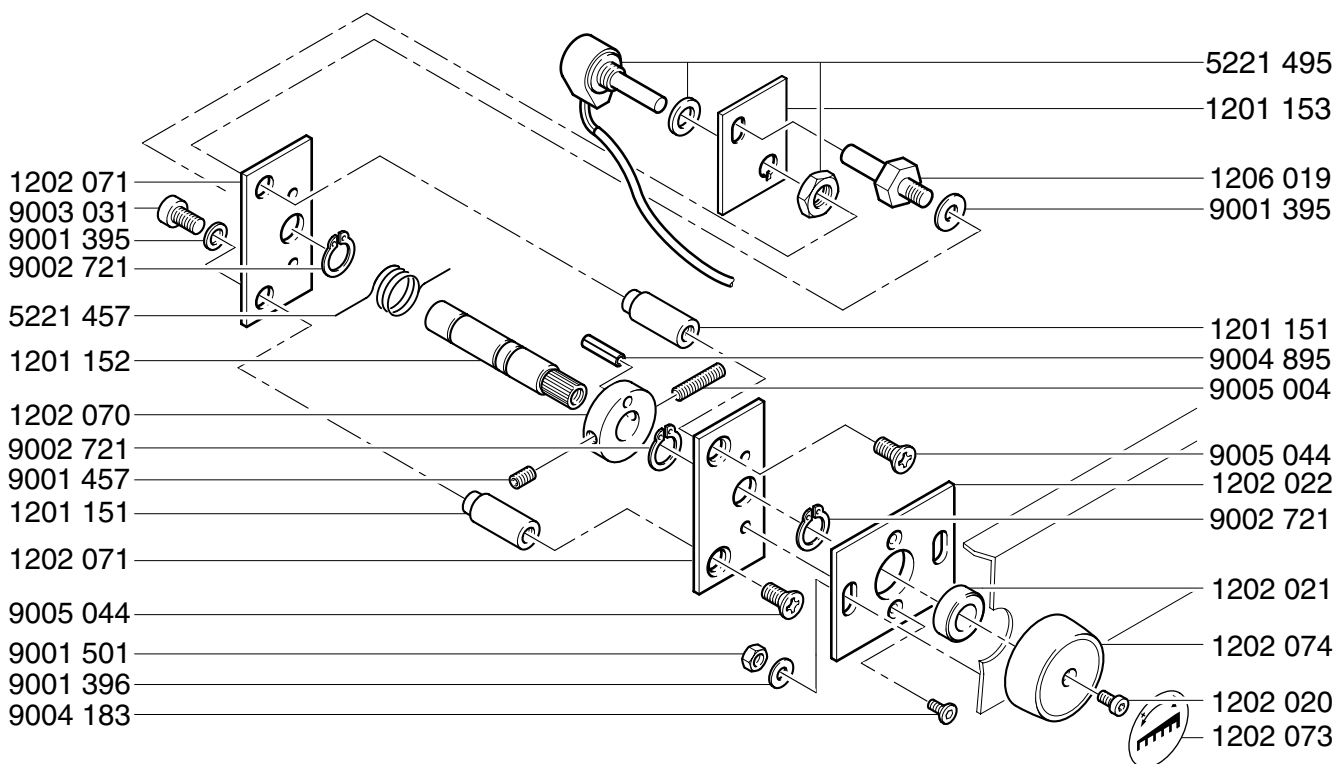
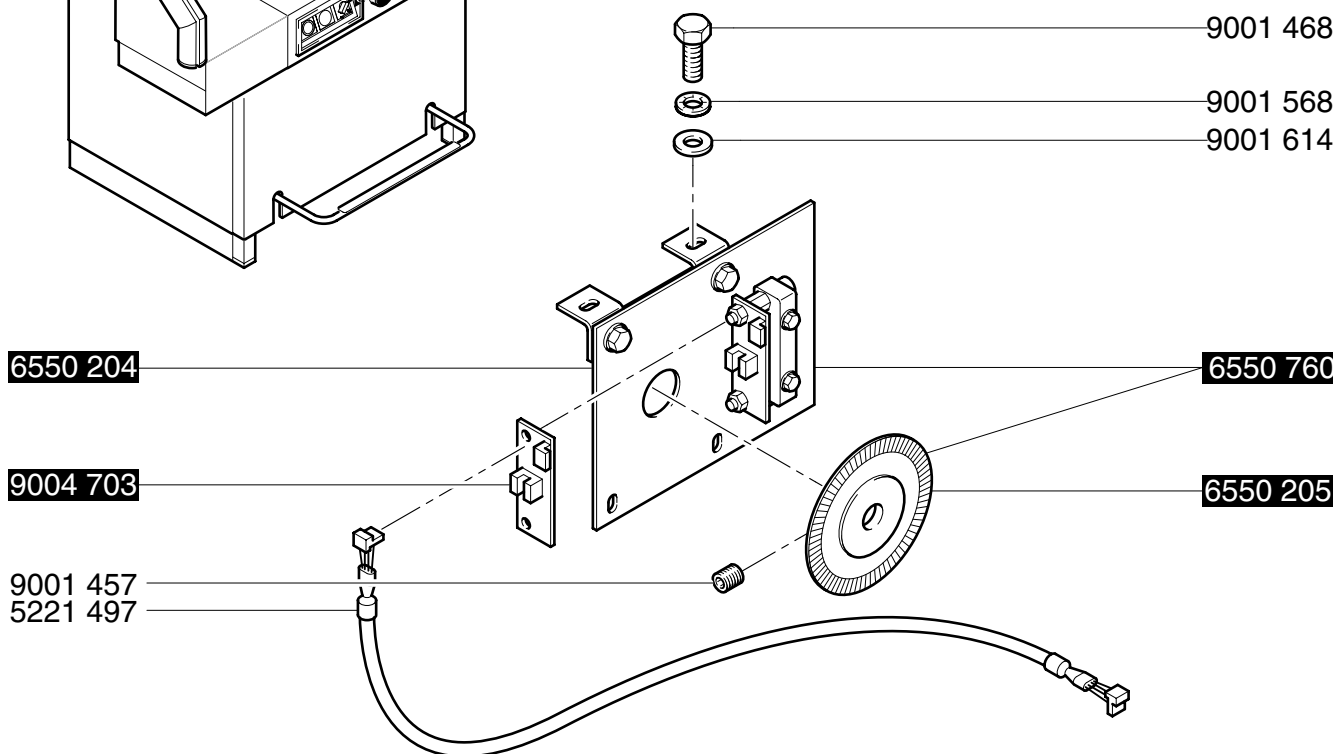
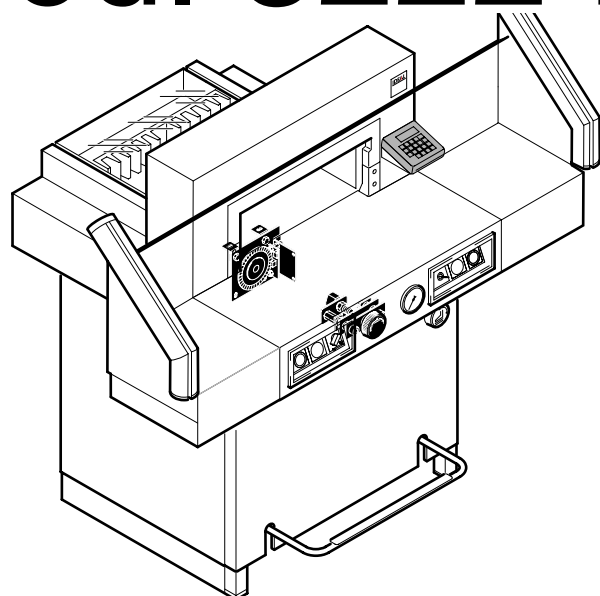

Mod. 5222 DIGICUT B

01.01.2011

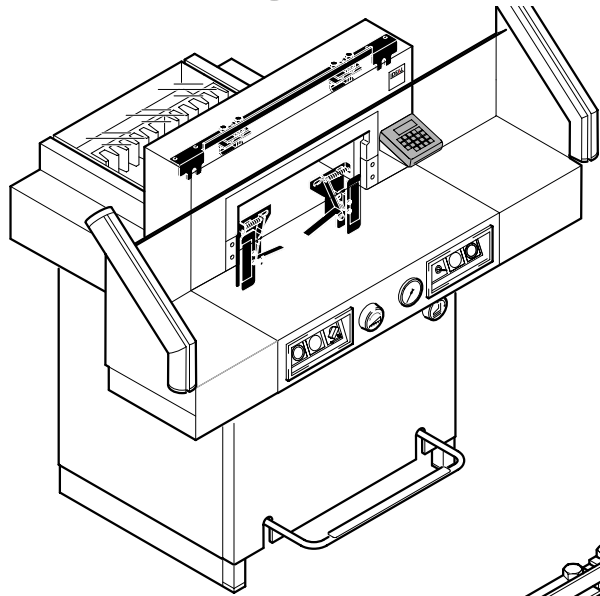

5006 279
9002 224
3600 016

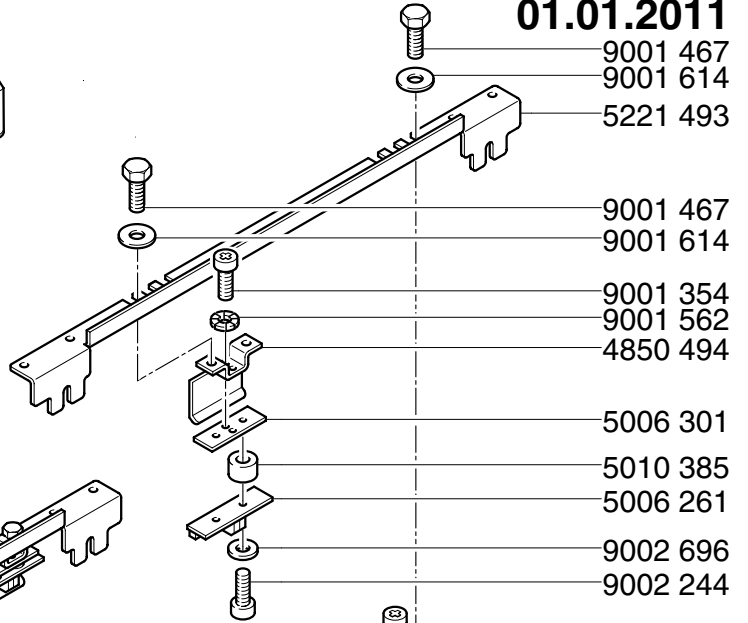

9001 467
9001 614
5221 493
9001 467
9001 614
9001 354
9001 562
4850 494
5006 301
5010 385
5006 261
9002 696
9002 244

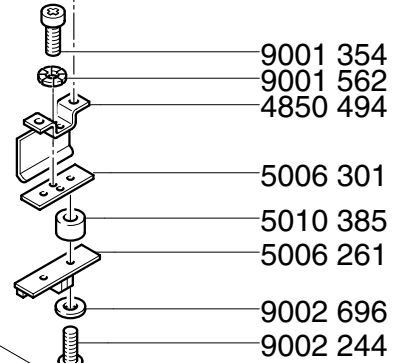
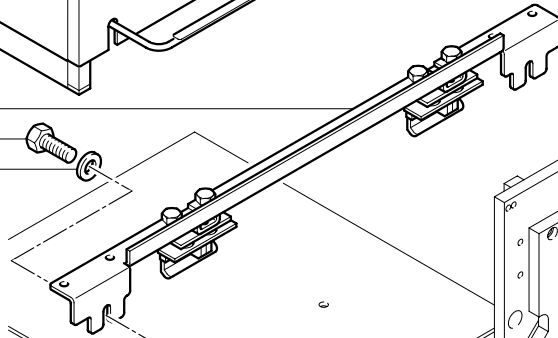

9001 354
9001 562
4850 494
5006 301
5010 385
5006 261
9002 696
9002 244

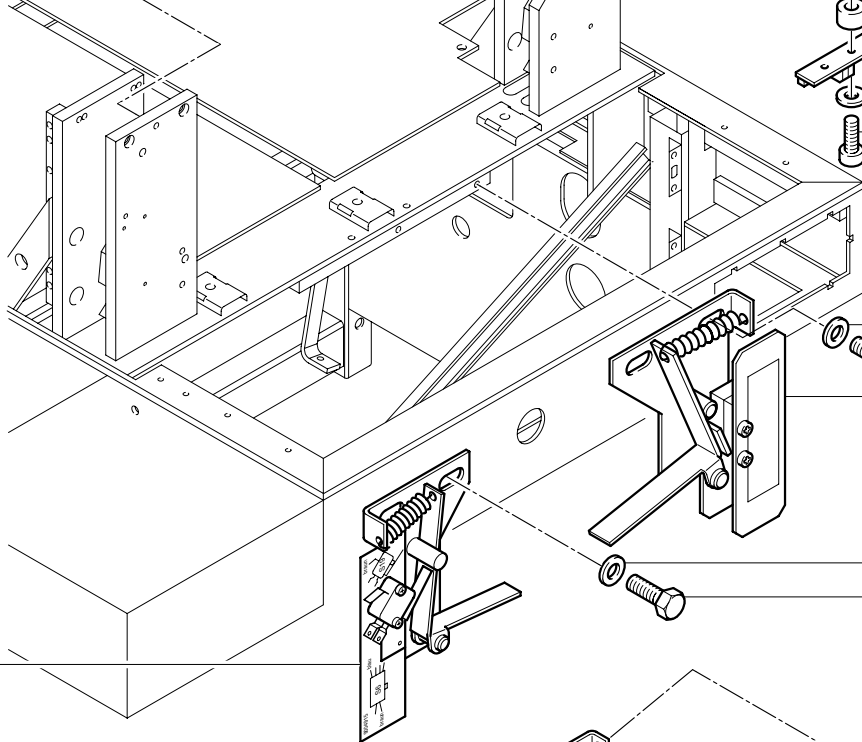

9001 216
9001 472
7240 154

7240 346

9001 497
9001 562
9003 488
5250 068
4810 496

9001 329
4810 530
7240 345
9002 996
9004 320

9001 574

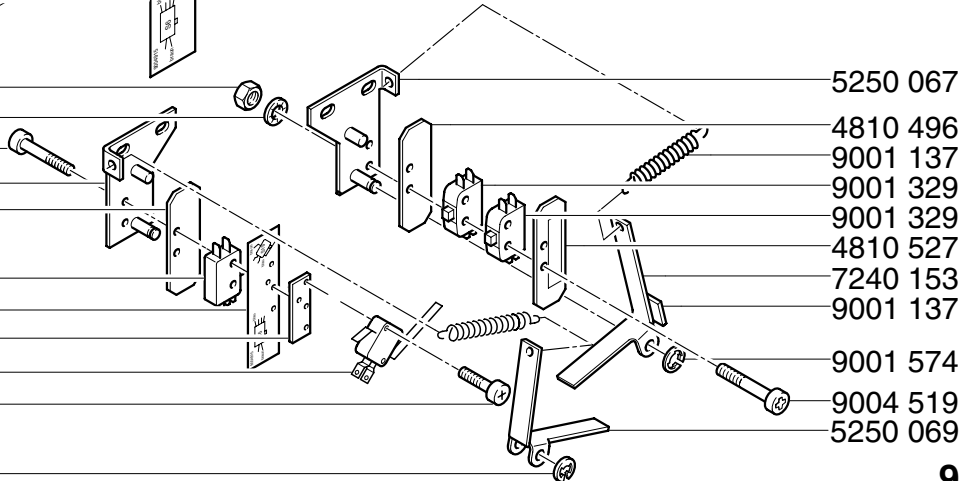

9001 216
9001 472

5250 067
4810 496
9001 137
9001 329
9001 329
4810 527
7240 153
9001 137
9001 574
9004 519
5250 069

Mod. 5222 DIGICUT B

01.01.2011

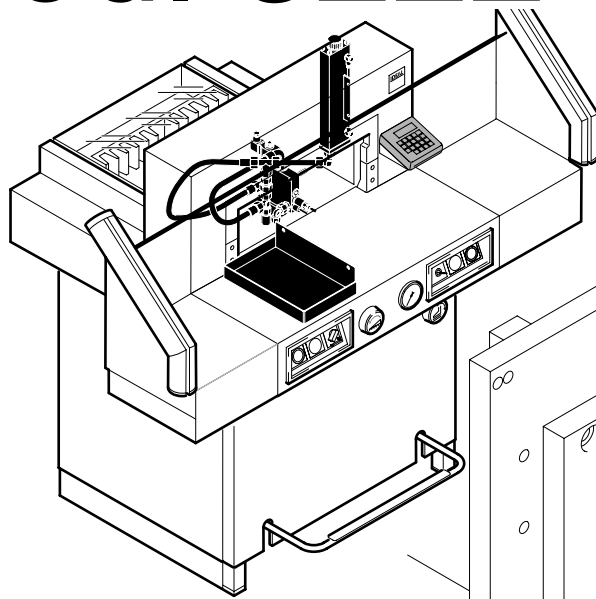

5006 274
9004 408

7240 230

7240 140
9004 411

5006 216
9004 407

9001 564
9002 419

9004 402
9005 474

5006 216
5006 217

zum Zylinder großes Zahnrad
to cylinder large tooth wheel
vers vérin couronne

zum Zylinder Pressung
to clamp cylinder
vers vérin de pression

9004 435

9005 446

7240 170

5006 275

9001 182

9002 604

9001 500

7240 170

9004 437

9004 430

9005 475

9004 402

9001 472

9001 564

5006 180

9004 536

9005 463

9004 432

9001 469

9001 614

9001 568

9001 499

5006 212

Mod. 5222 DIGICUT B

01.01.2011

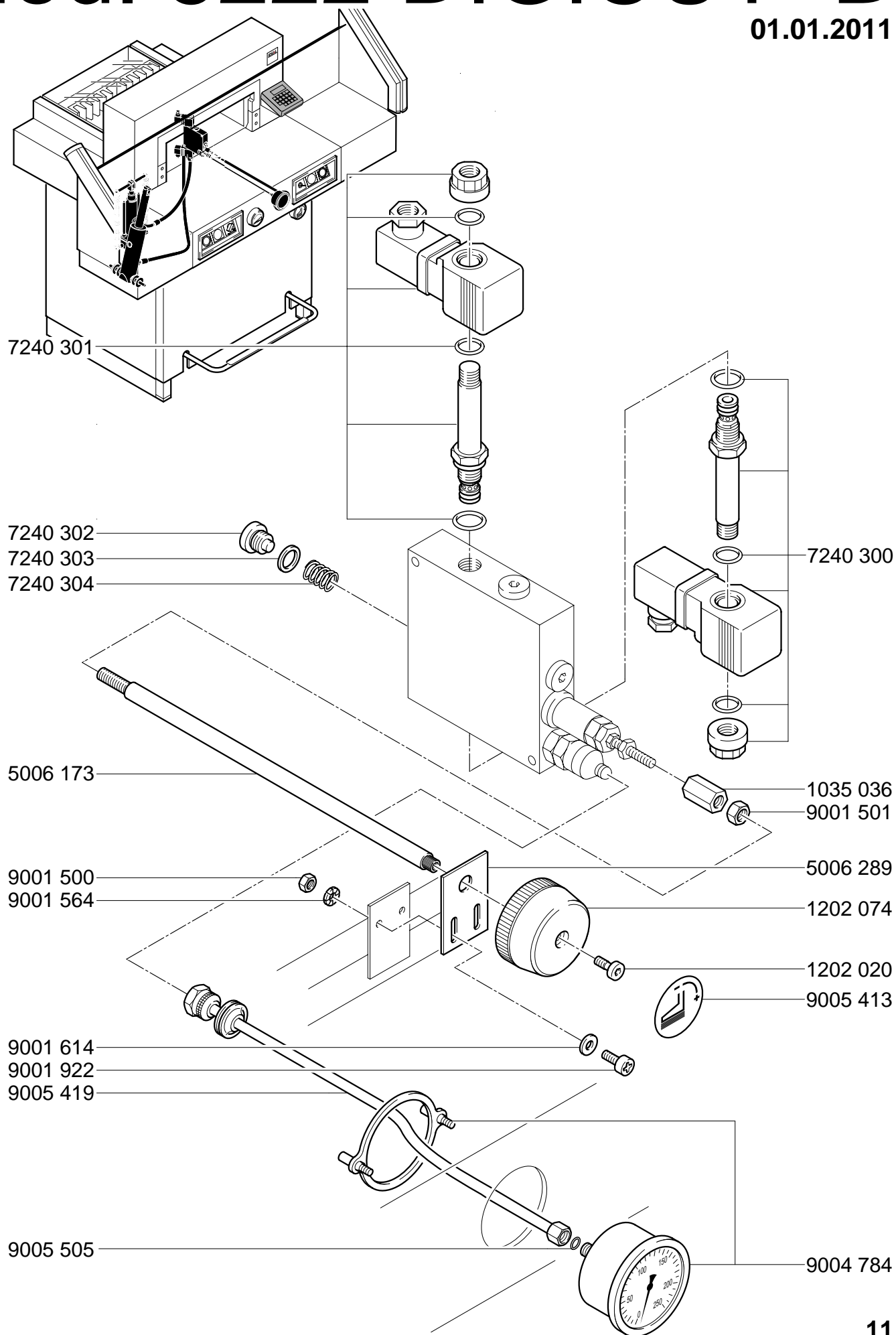

Mod. 5222 DIGICUT B

01.01.2011

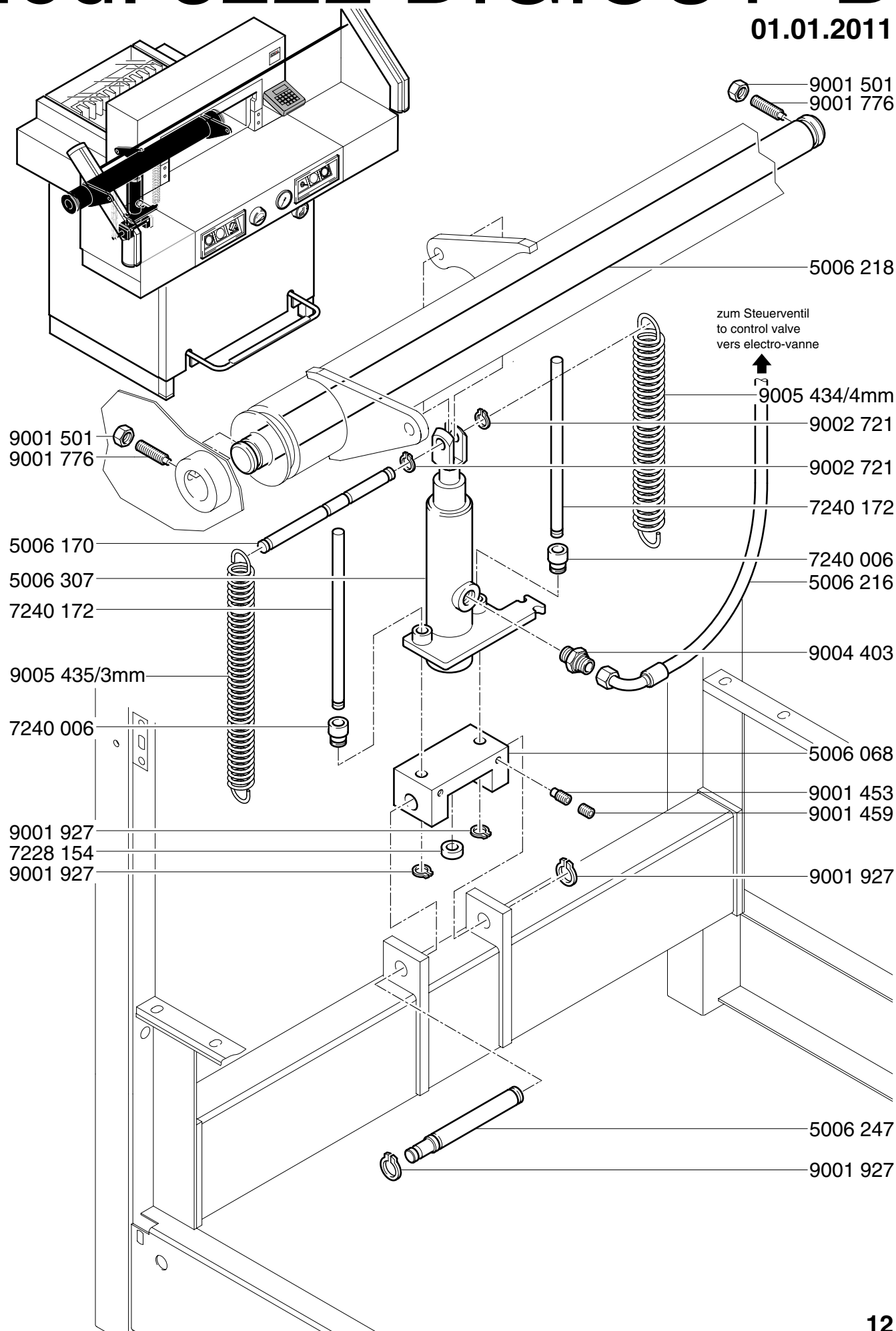

Mod. 5222 DIGICUT B

01.01.2011

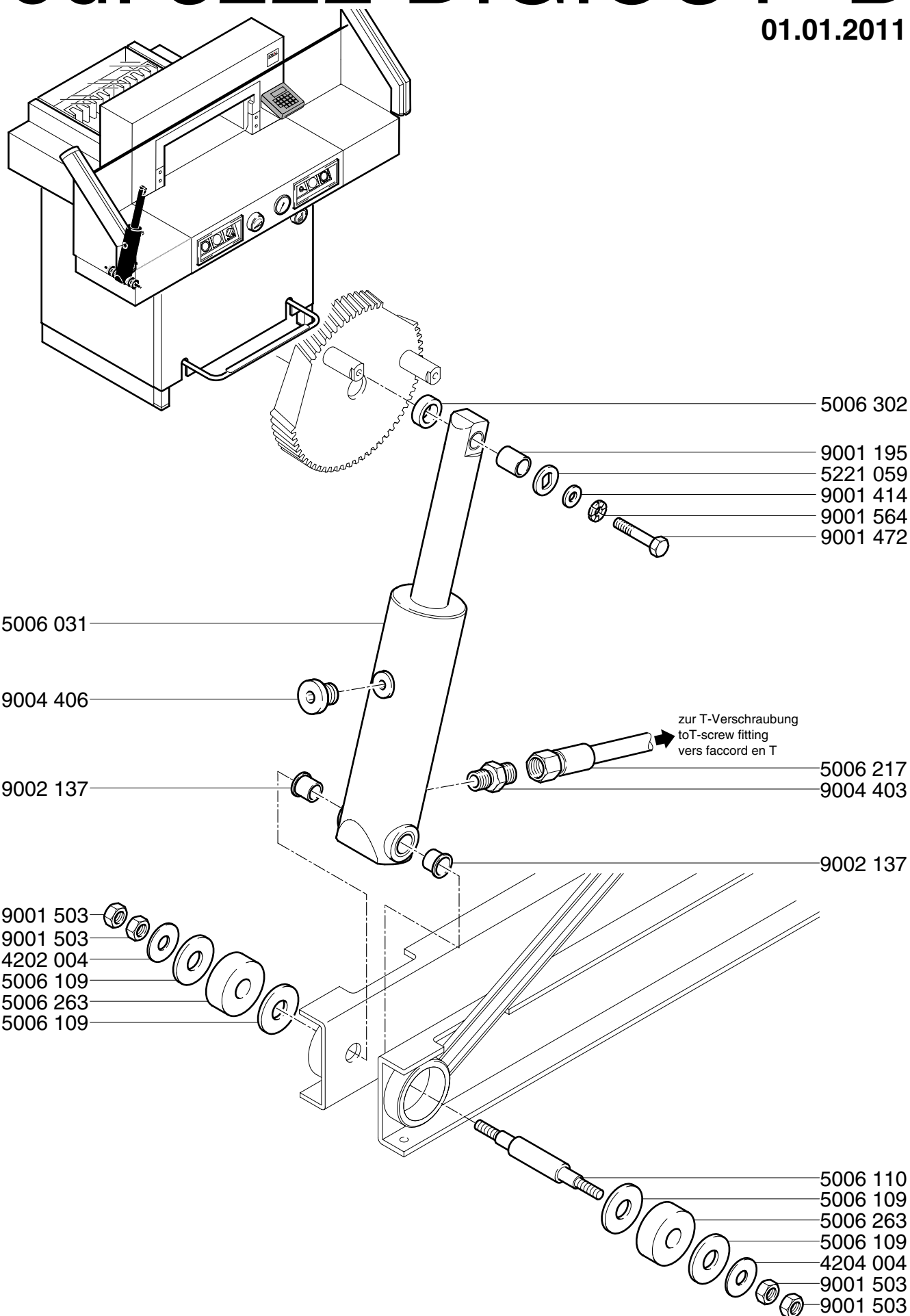

Mod. 5222 DIGICUT B

01.01.2011

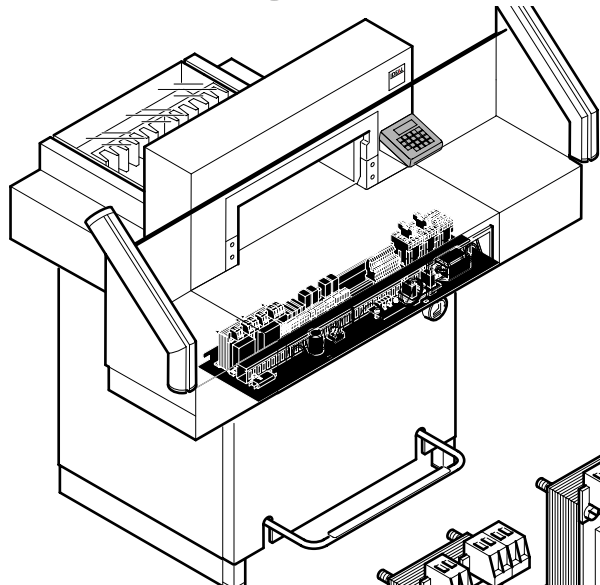

- 9003 295/100-115V
- 9003 296/220-240V
- 9001 179
- 9003 295/100-115V
- 9003 296/220-240V

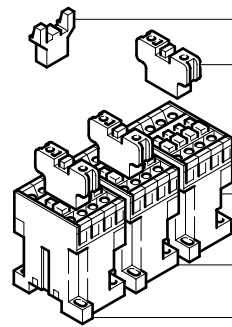

- 9004 377
- 9002 222
- 9002 231/100-115V
- 9002 112/220-240V
- 9002 231/100-115V
- 9002 112/220-240V

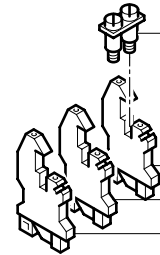

- 9002 599
- 9001 873

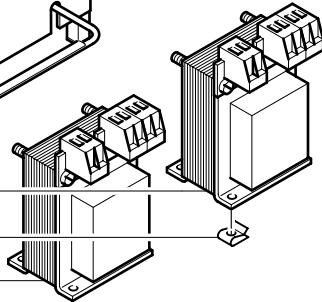

- 9002 492
- 9002 378
- 9002 573

- 9001 497
- 7228 717
- 2206 033

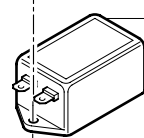
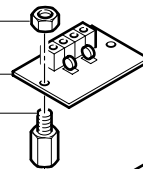

- 9001 498
- 9004 393

- 9001 497
- 9001 675
- 9001 675
- 2206 033
- 7240 375

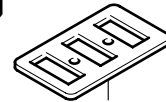
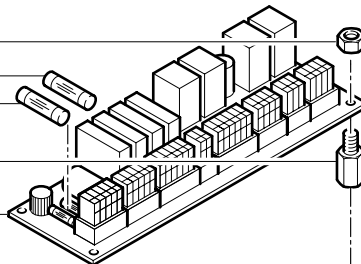

- 5221 122

- 9002 635
- 9002 636
- 9001 498
- 9001 563
- 9001 613



- 9001 498
- 9001 563
- 9001 613
- 9001 529

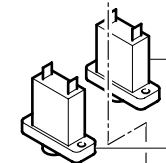

- 9001 244/100-115V
- 9001 242/220-240V

- 9001 240

- 9001 385
- 5006 310/120V
- 5006 371/230V

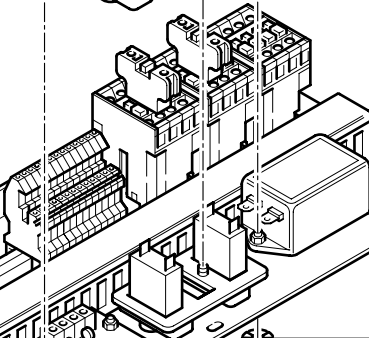
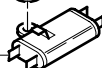

- 9001 499
- 9001 568
- 9001 614



- 9001 563
- 9001 364

- 9001 614
- 9001 469
- 9001 989
- 9001 364

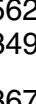
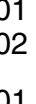
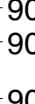
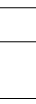
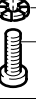
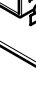
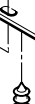
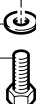

- 9001 563
- 9001 364
- 9001 563
- 9001 367
- 9001 562
- 9002 349
- 9001 562
- 9002 349
- 9001 367
- 9002 636
- 9001 565
- 9001 412

Mod. 5222 DIGICUT B

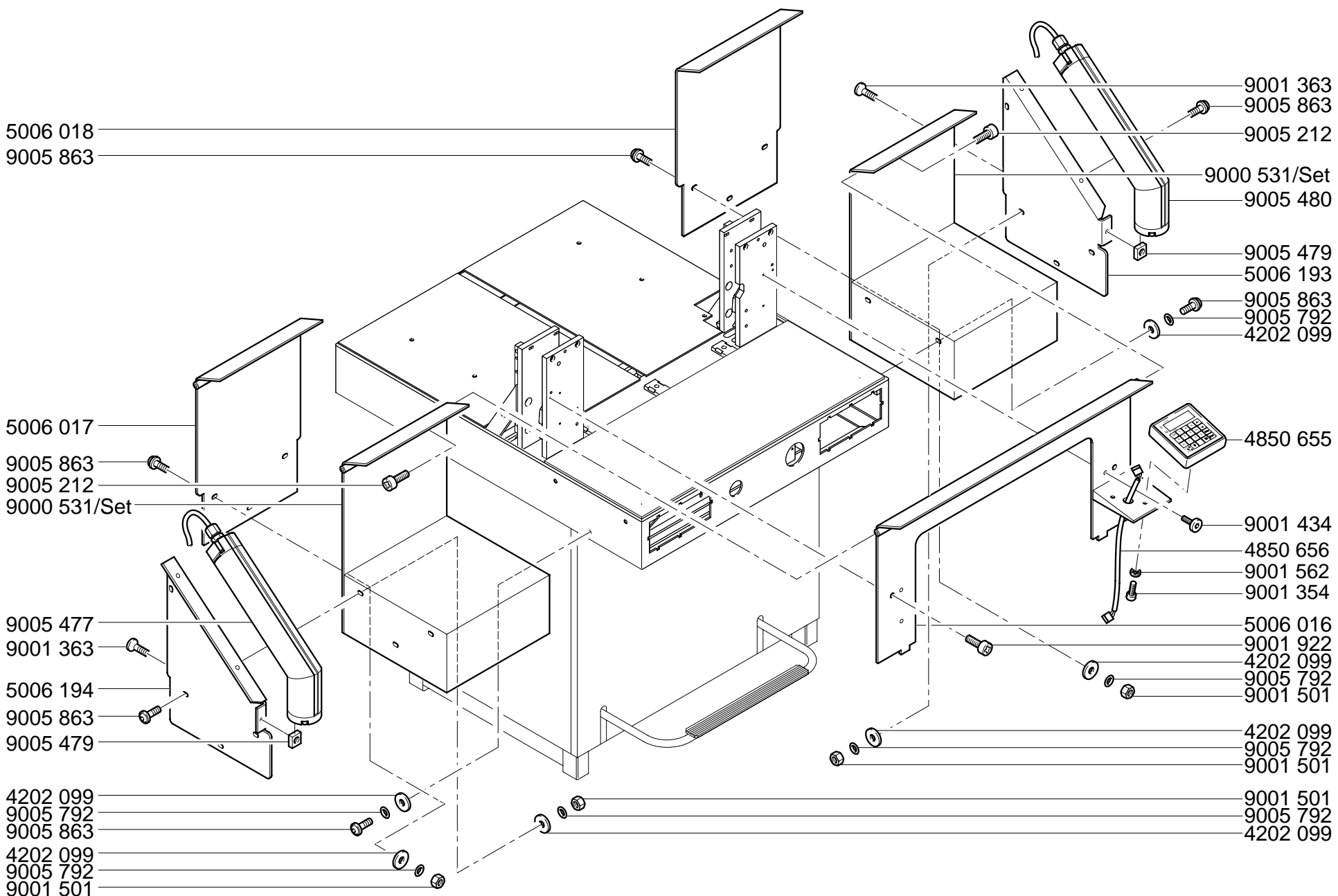

5006 018
9005 863

5006 017
9005 863
9005 212
9000 531/Set

9005 477
9001 363
5006 194
9005 863
9005 479

4202 099
9005 792
9005 863
4202 099
9005 792
9001 501

9001 363
9005 863
9005 212
9000 531/Set
9005 480
9005 479
5006 193
9005 863
9005 792
4202 099

4850 655

9001 434
4850 656
9001 562
9001 354

5006 016
9001 922
4202 099
9005 792
9001 501

4202 099
9005 792
9001 501

9001 501
9005 792
4202 099

Mod. 5222 DIGICUT B

01.01.2011

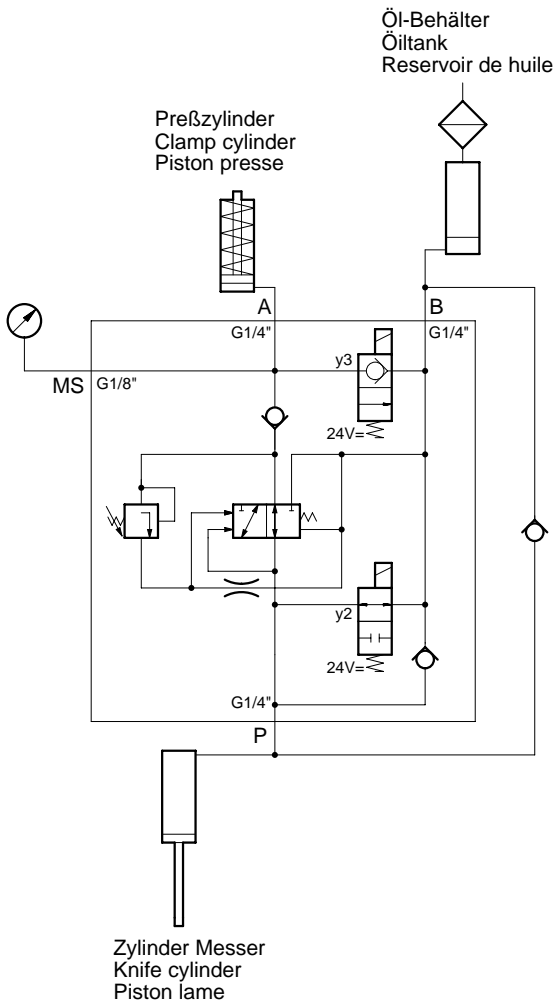
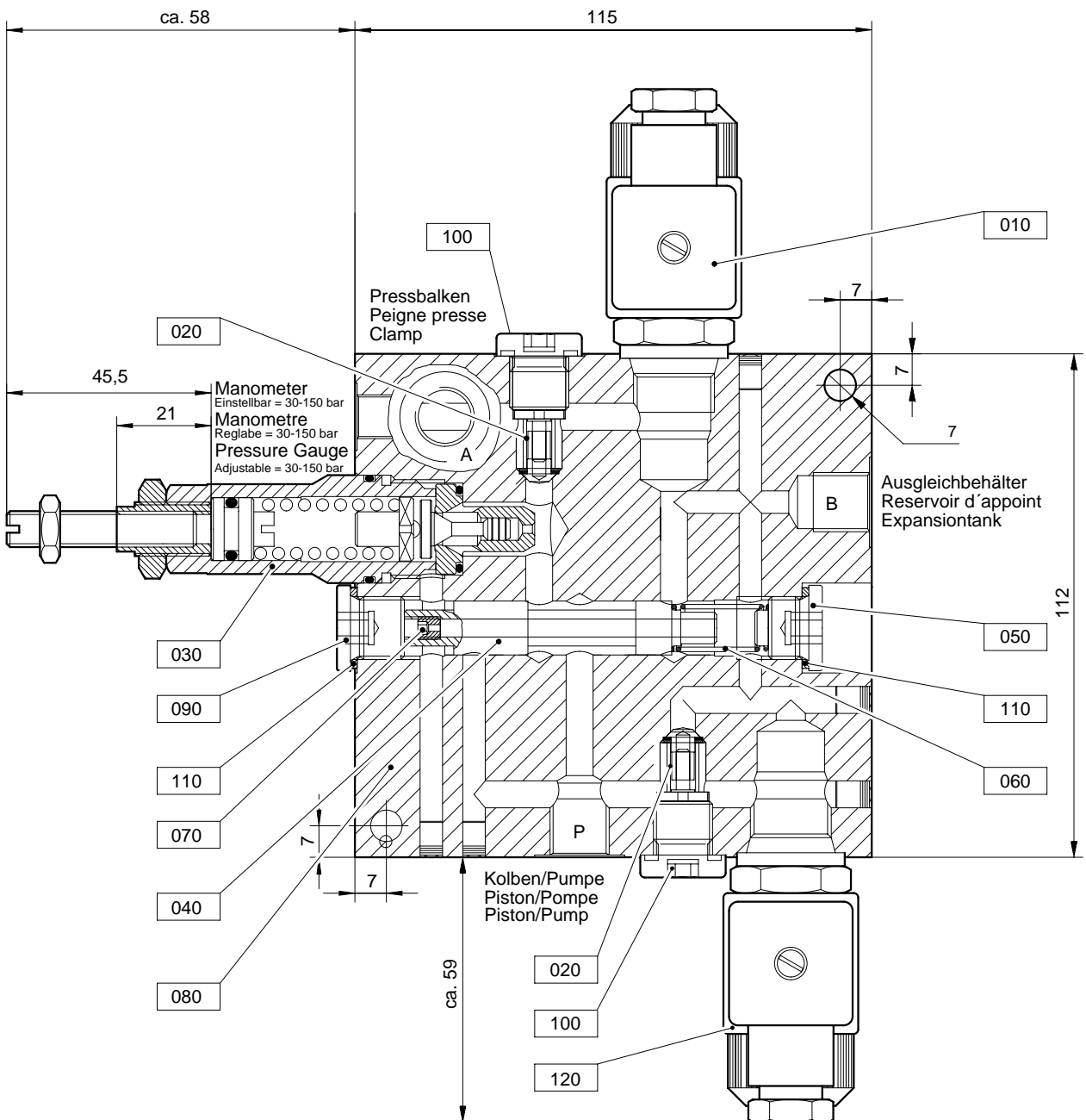

Mod. 5222 DIGICUT B

01.01.2011

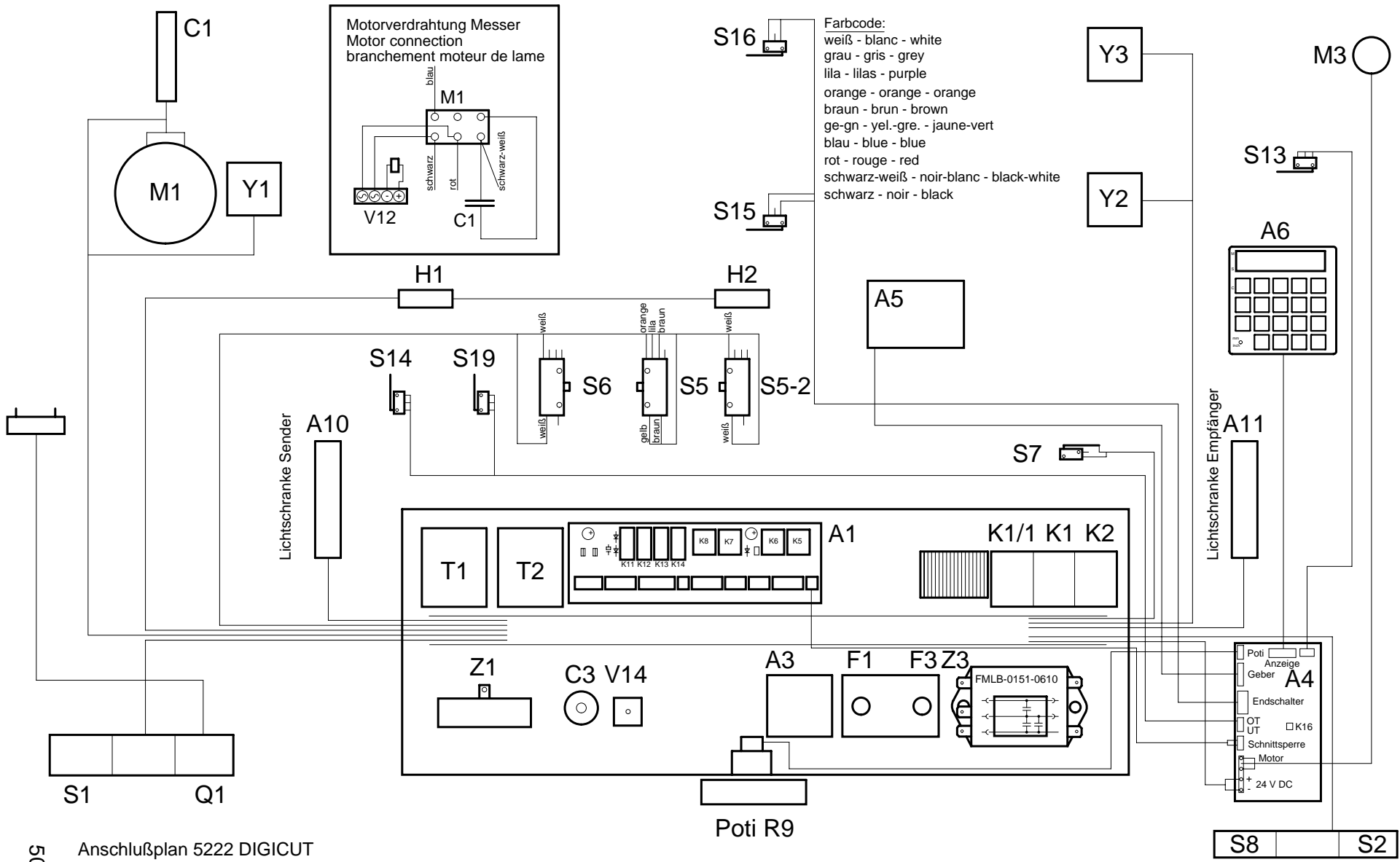

Anschlußplan 5222 DIGICUT
 Connecting diagram 5222 DIGICUT
 Diagramme de branchement 5222 DIGICUT

5006 292
 17

Mod. 5222 DIGICUT B

01.01.2011

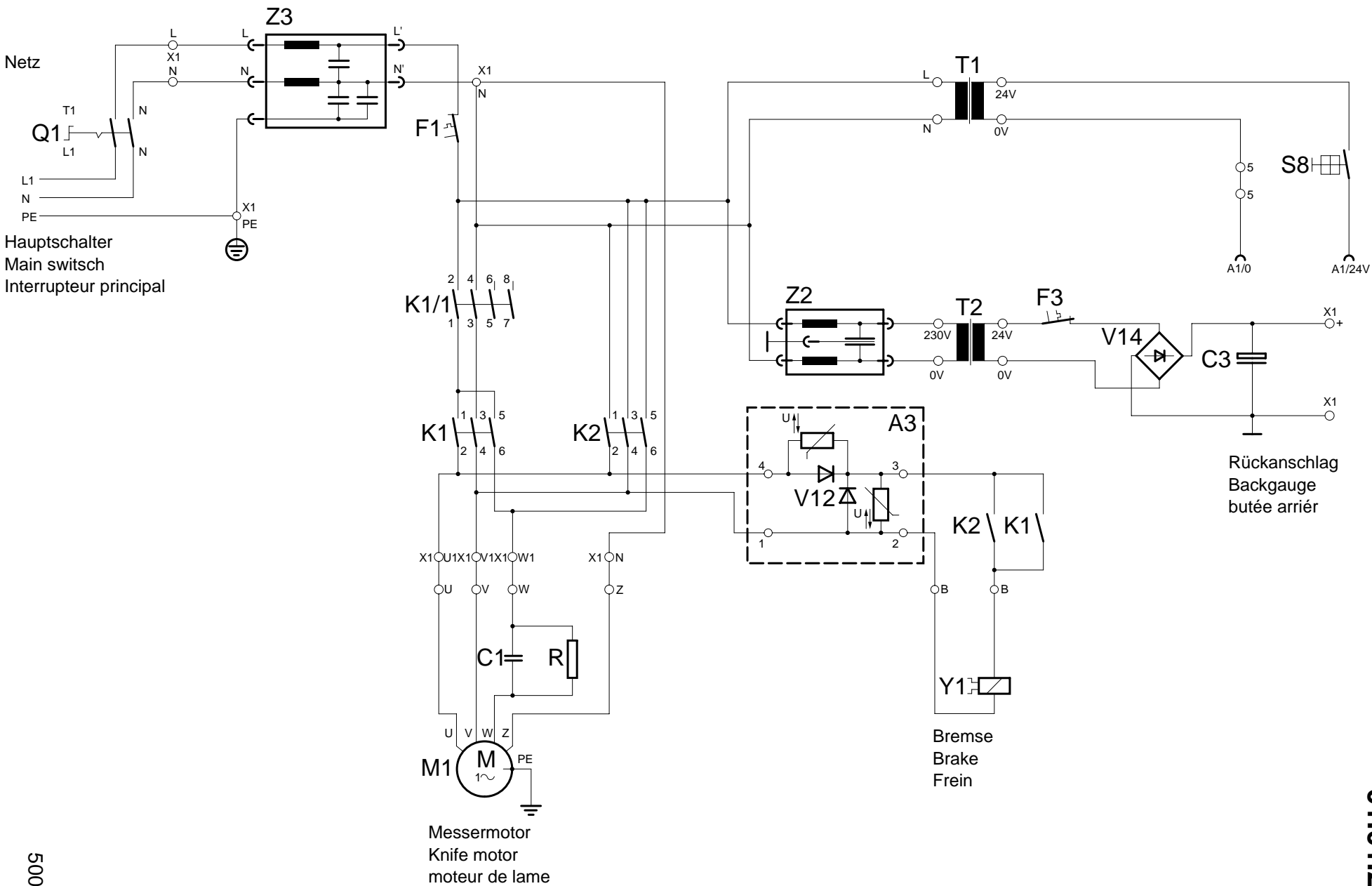

Mod. 5222 DIGICUT B

01.01.2011

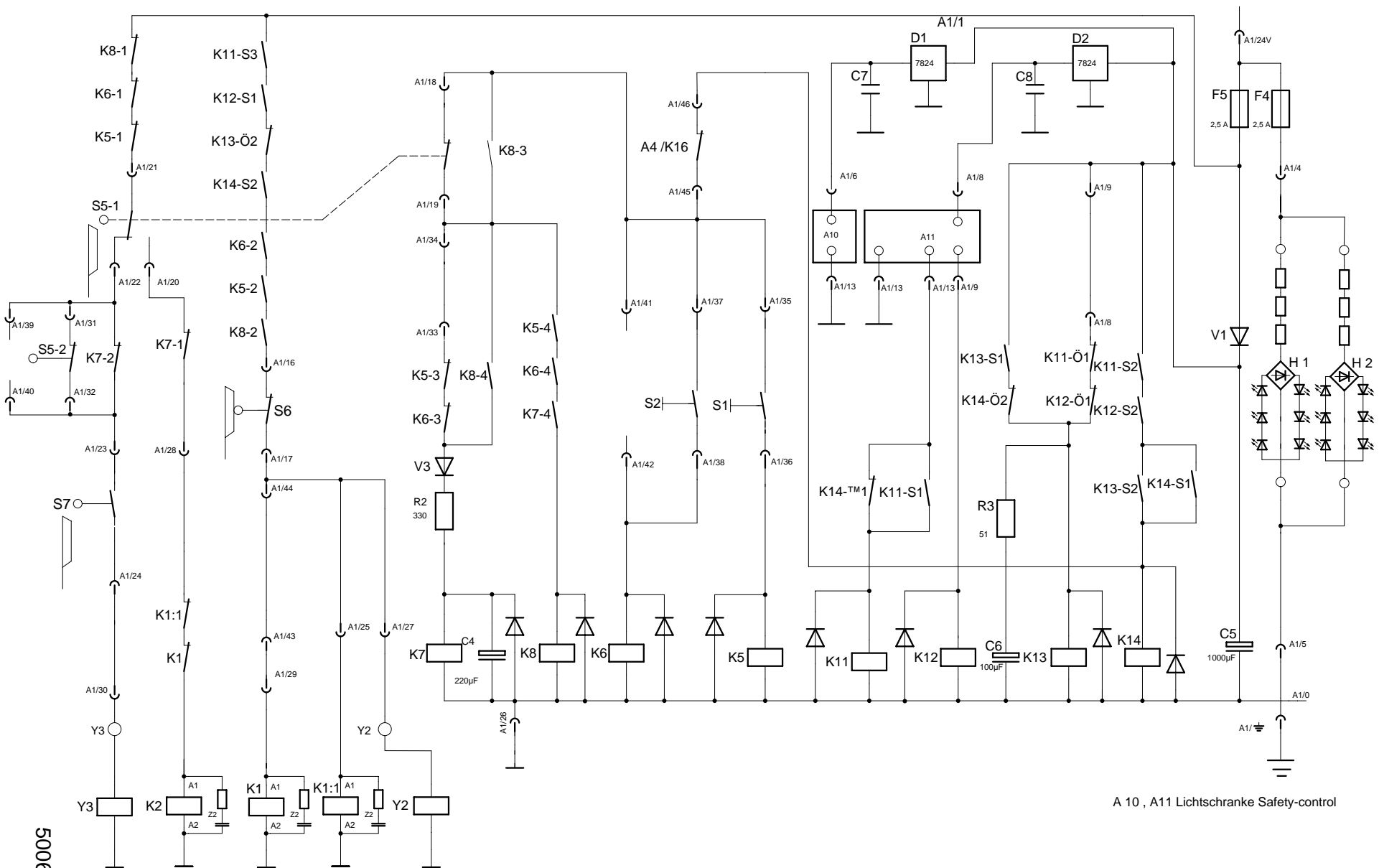

Index 5222 DIGICUT

- 1 -

Code	Deutsch	English	Francais	Holländisch	Italiano	Espanol
A1	Platine Steuerung	PCB - control	Platine de commande	Stuurprint	Scheda controllo	Placa de control
A3	Platine Bremse	PCB - Brake	Platine Frein	Remprint	Scheda Freno	Placa de Reno
A4	Platine Rückanschlag	PCB-backgauge	Platine butée arrière	Zadelmotorsturing	Scheda di battuta posteriore	Placa escuadra trasera
A5	Platine Geber	PCB-counter	Platine compteur d'impulsions	Print teller	Scheda contatore	Placa del contactor
A6	Platine Tastatur, Anzeige	PCB keyboard, display	Pupitre de commande EC	Print display EC	Scheda display EC	Placa de display EC
A10	Lichtschranke Sender	Photo cell transmitter	Cellule emettrice	Photocel zender	Fotocellula trasmissente	Transmisor célula fotoeléctrica
A11	Lichtschranke Empfänger	Photo cell receiver	Cellule receptrice	Photocel ontvanger	Fotocellula ricevente	Receptor célula fotoeléctrica
C1	Kondensator	Capacitor	Condensateur	Condensator	Condensatore	Condensador
C4	Kondensator	Capacitor	Condensateur	Condensator	Condensatore	Condensador
C5	Kondensator	Capacitor	Condensateur	Condensator	Condensatore	Condensador
C6	Kondensator	Capacitor	Condensateur	Condensator	Condensatore	Condensador
F1	Überlastschutz Messer	Knife overload	Disjoncteur lame	Overbel.schakelaar mesm.	Interruttore sovraccarico lama	Disyuntor estribo cuchilla
F3	Überlastschutz Rückans.	Backgauge overload	Disjoncteur butée arrière	O. schakelaar achteraanleg	Interr. sovr. di buttata posteriore	Disyuntor escuadra trasera
F4	Sicherung	Fuse	Fusible	Zekering	Fusibile	Fusible
F5	Sicherung	Fuse	Fusible	Zekering	Fusibile	Fusible
H1	Schnittandeuter	Cutting line light	Ampoule ligne de coupe	Snijlijnverlichting	Indicatore taglio	Luz línea de corte
H2	Schnittandeuter	Cutting line light	Ampoule ligne de coupe	Snijlijnverlichting	Indicatore taglio	Luz línea de corte
K1/1	Schütz Messer ab	Knife-down contactor	Contacteur descente de lame	Relais mes omlaag	Interr. autom. discesa lama	Contactor bajada cuchilla
K1	Schütz Messer ab	Knife-down contactor	Contacteur desconte de lame	Relais mes omlaag	Interr. autom. discesa lama	Contactor bajada cuchilla
K2	Schütz Messer auf	Knife-up contactor	Contacteur remontée de lame	Relais mes omhoog	Interr. autom. risalita lama	Contactor subida cuchilla
K5	Relais Taster links	Relay push button left	Relais touche gauche	Relais drukknop links	Relais pulsante sinistro	Relè botón izquierdo
K6	Relais Taster rechts	Relay push button right	Relais touche droite	Relais drukknop rechts	Relais pulsante destro	Relè botón derecho
K7	Relais Verzögerung	Time-delay relay	Relais retard	Vertragingrelais	Relais di ritardo	Relè de atraso
K8	Relais Schnittwiederholung	Relay Cutting repetition	Relais répétition de coupe	Relais snijgangherhaling	Relais ripetizione taglio	Relè repitición corte
K11	Sicherheitsrelais Klappe	Relay safety flap	Relais volet de sécurité	Veiligheidsrelaiskap	Relais coperchio sicurezza	Relè tapa de seguridad
K12	Sicherheitsrelais Klappe	Relay safety flap	Relais volet de sécurité	Veiligheidsrelaiskap	Relais coperchio sicurezza	Relè tapa de seguridad
K13	Sicherheitsrelais Klappe	Relay safety flap	Relais volet de sécurité	Veiligheidsrelaiskap	Relais coperchio sicurezza	Relè tapa de seguridad
K14	Sicherheitsrelais Klappe	Relay safety flap	Relais volet de sécurité	Veiligheidsrelaiskap	Relais coperchio sicurezza	Relè tapa de seguridad
M1	Antriebsmotor Messer	Cutting motor	Moteur lame	Snijmotor	Motore lama	Motor de corte
M3	Motor Rückanschlag	Backgauge motor	Moteur butée arrière	Motor achteraanleg	Motore di battuta posteriore	Motor escuadra trasera

Index 5222 DIGICUT

- 2 -

Code	Deutsch	English	Francais	Holländisch	Italiano	Espanol
Q1	Hauptschalter	Main switch	Interrupteur principal	Hoofdschakelaar	Interruttore principale	Interruptor principal
R2	Widerstand	Resistor	Résistance	Weerstand	Resistenza	Resistencia
R9	Poti Rückanschlag	Poti back gauge	Poti butée arrière	Poti achteraanleg	Poti di buttata posteriore	Poti escuadra trasera
S1	Taster Messer + Presse	Push button knife and clamp	Touche de commande lame + presse	Druknop mes + pers	Pulsante lama + pressino	Botón de la cuchilla y prensa
S2	Taster Messer + Presse	Push button knife and clamp	Touche de commande lame + presse	Druknop mes + pers	Pulsante lama + pressino	Botón de la cuchilla y prensa
S5	OT-Stopschalter Messer	Switch knife top	Arrêt lame haut	Schakelaar mes boven	Fermo lama alto	Interruptor subida cuchilla
S6	UT-Stopschalter Messer	Switch knife bottom	Arrêt lame bas	Schakelaar mes beneden	Fermo lama basso	Interruptor bajada cuchilla
S7	OT-Stopschalter Presse	Switch clamp on top	Arrêt presse Haut	Schakelaar persbalk boven	Fermo pressino alto	Interruptor subida prensa
S8	Schaltenschloß	Key switch	Contacteur a clé	Sleutelschakelaar	Interruttore a chiave	Llave interruptor
S10	Sicherheitsschalter Klappe	Switch safety flap	Micro-contact volet de sécurité	Veiligheidsschakelaar kap	Interr. coperchio sicurezza	Interruptor tapa de seguridad
S11	Sicherheitsschalter Klappe	Switch safety flap	Micro-contact volet de sécurité	Veiligheidsschakelaar kap	Interr. coperchio sicurezza	Interruptor tapa de seguridad
S12	Sicherheitsschalter Klappe	Switch safety flap	Micro-contact volet de sécurité	Veiligheidsschakelaar kap	Interr. coperchio sicurezza	Interruptor tapa de seguridad
S13	Schalter Elektronik 21/60	Switch electronic 21/60	Inverseur 21/60 électronique	Schakelaar electronica 21/60	Interruttore elettronice 21/60	Interruptor electronico 21/60
S14	OT-Pressse Elektronik	Switch clamp up	Micro-contact presse en position haut	Schakelaar pers omhoog	Interruttore elettr. pressino in alto	Interruptor subida prensa
S15	Rückanschlag vorne/Stop	Switchg backgauge forward/stop	Fin de course avant butée arrière	Schakelaar schakelpunt voor	Interruttore anteriore	Interruptor marca frontal
S16	Rückanschlag rück/Stop	Switch backgauge backward/stop	Fin de course arrière butée arrière	Schakelaar schakelpunt achter	Interruttore posteriore	Interruptor marca trasera
S19	UT-Messer Elektronik	Switch knife up	Arrêt lame bas	Schakelaar mes beneden	Fermo lama basso	Interruptor bajada cuchilla
T1	Transformator	Transformer	Transformateur	Transformator	Transformatore	Transformador
T2	Transformator	Transformer	Transformateur	Transformator	Transformatore	Transformador
V1	Diode	Diode	Diode	Diode	Diodo	Diode
V2	Diode	Diode	Diode	Diode	Diodo	Diode
V3	Diode	Diode	Diode	Diode	Diodo	Diode
V12	Gleichrichter Bremse	Rectifier	Redresseur frein	Gelijkrichter rem	Raddrizzatore freno	Rectificador
V14	Gleichrichter Rückanschl.	Rectifier backgauge	Redresseur butée arrière	Gelijkrichter achteraanleg	Reddrizzatore di battuta posteriore	Rectificador escuadra trasera
Y1	Bremse Messermotor	Brake, knife motor	Frein moteur de lame	Rem snijmotor	Freno motore lama	Freno motor cuchilla
Y2	Ventil AB	Vanne le hau	Ventiel omhoog	Valvola verso l' alto	Filtro RC suppressor	Freno motor prensa
Y3	Ventil AUF	Valve down	Vanne le hau	Ventiel omhoog	Valvola verso l' alto	Filtro RC suppressor
Z1	Drossel	Throttle	Self	Ontstoorspoel	Valvola di regolazione	Válvula reguladora
Z2	RC-Filter	Radio frequency suppressor	Frein moteur de presse	Ontstoorfilter	Filtro antidisturbo	Filtro RC
Z3	Drossel	Throttle	Self	Ontstoorspoel	Valvola di regolazione	Válvula reguladora

Mod. 5222 DIGICUT B

01.01.2011

